



Department of Electronics and Communications Engineering

## **PROJECT ON LINE FOLLOWER ROBOT WITHOUT USING MICROCONTROLLER**

Prepared By

NazmunNahar  
ID: 2012-2-55-012

TahminaAkter  
ID:2012-1-55-020

Dept. of ECE  
East West University

Supervised By

Md. Asif Hossain  
Senior Lecturer, Dept. of ECE

August 2016

# Letter of Transmittal

To  
Md. Asif Hossain  
Senior Lecturer  
Department of Electronics and Communication Engineering  
East West University

**Subject: Submission of Project Report as (ETE-498)**

Dear Sir,

We are pleased to let you know that we have completed our project on **Line Follower Robot without Microcontroller**. The attachment contain of the project that has been prepared for your evaluation and consideration. Working on this project has given us some new concepts. By applying those concept we have tried to make something innovative by using our theoretical knowledge which we have acquired since last four years from you and the other honorable faculty members of EWU. This project would be a great help for us in future.

We are very grateful to you for your guidance, which helped us a lot to complete my project and acquire practical knowledge.

Thanking You.

Yours Sincerely

NazmunNahar  
ID# 2012-2-55-012

TahminaAkter  
ID# 2012-1-55-020

Dept. of ECE  
East West University

# Declaration

This is certified that the project is done by us under the course “Project (ETE-498)”. The project of **Line Follower Robot without Microcontroller** has not been submitted elsewhere for the requirement of any degree or any other purpose except for publication.

-----  
NazmunNahar  
ID# 2012-2-55-012

-----  
TahminaAkter  
ID# 2012-1-55-020

# Acceptance

This Project paper is submitted to the **Department of Electronics and Communication Engineering, East West University** is submitted in partial fulfillment of the requirements for the degree of **Bachelor of Science in Electronics & Telecommunications Engineering (ETE)** under complete supervision of the undersigned.

---

**Md. Asif Hossain**  
Senior Lecturer  
Dept. of ECE  
East West University

# **Abstract**

Line Follower robot is a machine that follows a line, either a black line on white surface or vice-versa. Nowadays, every robot is done with the help of the microcontroller, and hence the circuit is too big and tough to understand and makes it costly. For these reasons, in this project we have developed an intelligent Line follower robot with a simple concept with simple circuitry. Basically there are two types of line follower robots: one is black line follower which follows black line and second is white line follower which follows white line. Here we have designed the first one. Line follower actually senses the line and run over it.

# TABLE OF CONTENTS

## Contents

CHAPTER1:INTRODUCTION .....	6
CHAPTER 2:PRELIMINARY DESIGN.....	9
Component List .....	10
CircuitDiagram .....	11
CHAPTER 3: HARDWARE DISCRPTION .....	12
CHAPTER 4: WORKING PRINCIPLES .....	22
CHAPTER 5: APPLICATION.....	29
CHAPTER 6:FURTHER IMPROVEMENTS .....	31
CHAPTER 7: CONCLUSION.....	33
REFERENCES.....	35

# **CHAPTER 1**

# **INTRODUCTION**

A line following robot is a mobile machine employed to sense and follow the black lines that are drawn on the white surface. As this robot is developed using a breadboard, it will be very simple to construct. This technique can be incorporated into the Automated Guided Vehicles (AGV) for providing the easy way of operation.

Generally, the AGV is integrated with the microprocessor and computers for controlling its system. It also uses a position feedback system for traveling in the desired path. In addition, the electric signals and RF communication are needed for communicating with the vehicle and system controller. Such awkward functions are completely not required in this line following robot, and it just uses the IR sensors to travel on the black lines.

Unlike room-exploration robots that often get stuck against chairs and carpet edges, you don't have to chase after a well-designed line-following robot. Most line-following robots have two motors, two front sensors, and a basic electronic circuit for autonomous control. But, a great thing about this type of robot is that it is easy to make small changes for added complexity. Simple improvement is to install the robot in a decorative container, along with colorful LEDs. More advanced designs add various sensors and a programmable microcontroller for faster speed, smoother turning, or maze-solving.



# **CHAPTER 2**

# **PRELIMINARY DESIGN**

This chapter will describe the preliminary design and the materials needed for the project.

**Table 1: Component List**

<b>Product Name</b>	<b>Quantity</b>
Robotic Chassis(with 2 Wheel& DC Motors)	1
Breadboard	1
ULN 2003 IC	1
Battery 9V	1
Battery AAA	4
2 Array IR Sensor	1
LED Blue - 5mm	1
Breadboard Jumper Wires	1
Battery snap	1
Battery holder	1

**Description:**

We have arranged the components according to the Fig. 2. An ULN 2003 IC has been connected with the motors, sensors and the power. The IR sensors has been connected with lower part of the robot chassis. This sensor will sense the light and give the feedback to the circuit to drive the motors. The complete working principle will be discussed in Chapter 4.

## Circuit Diagram

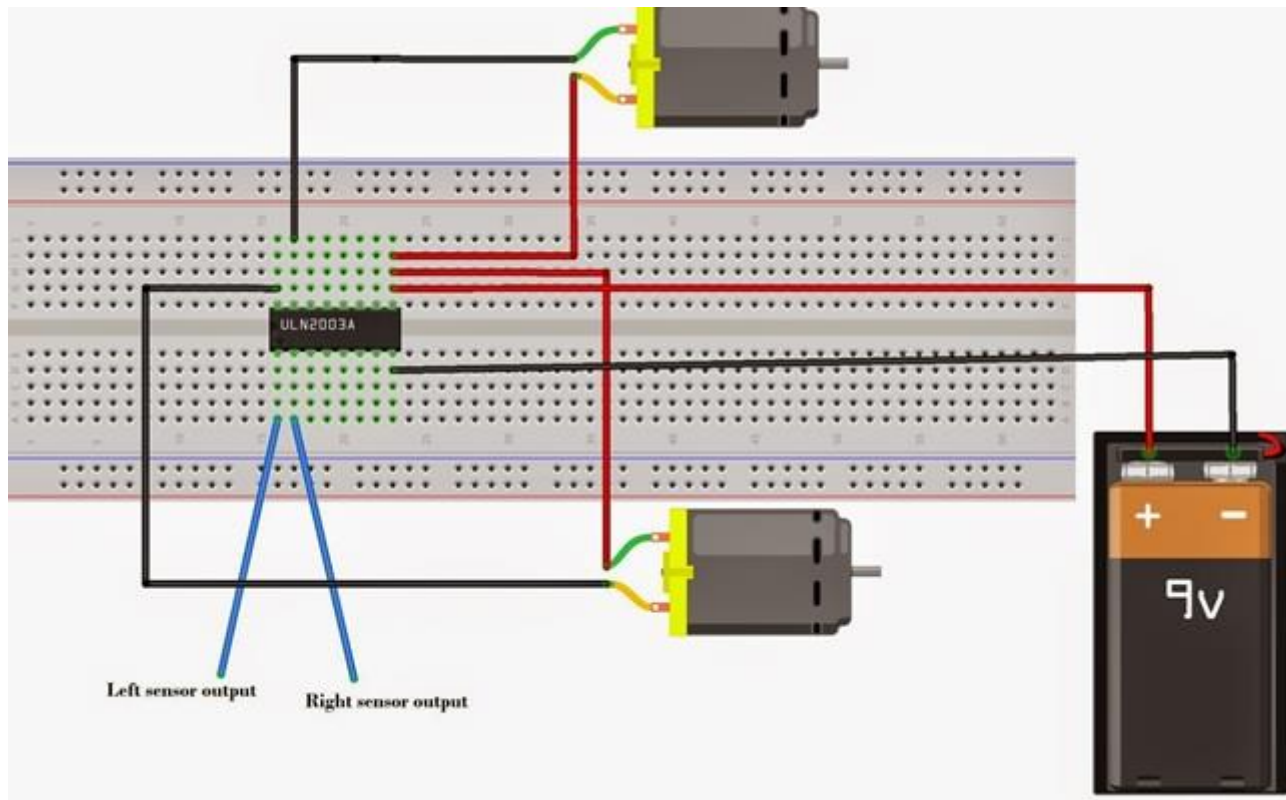

Fig. 2 Circuit diagram of the project

### IC ULN 2003 Connections:

- We Connected 1<sup>st</sup> & 2<sup>nd</sup> pin of ULN2003 with the output of the SEN1 & SEN2 of the sensors Left & Right respectively.
- 8<sup>th</sup> pin (GND) has been connected with the negative part of the battery.
- Left & Right motors' negative parts have been connected with the pin# 15<sup>th</sup> & 16<sup>th</sup> respectively.
- 9<sup>th</sup> pin are connected with two motors positive parts and the positive part of the battery.

The final photo of our project has been shown below:

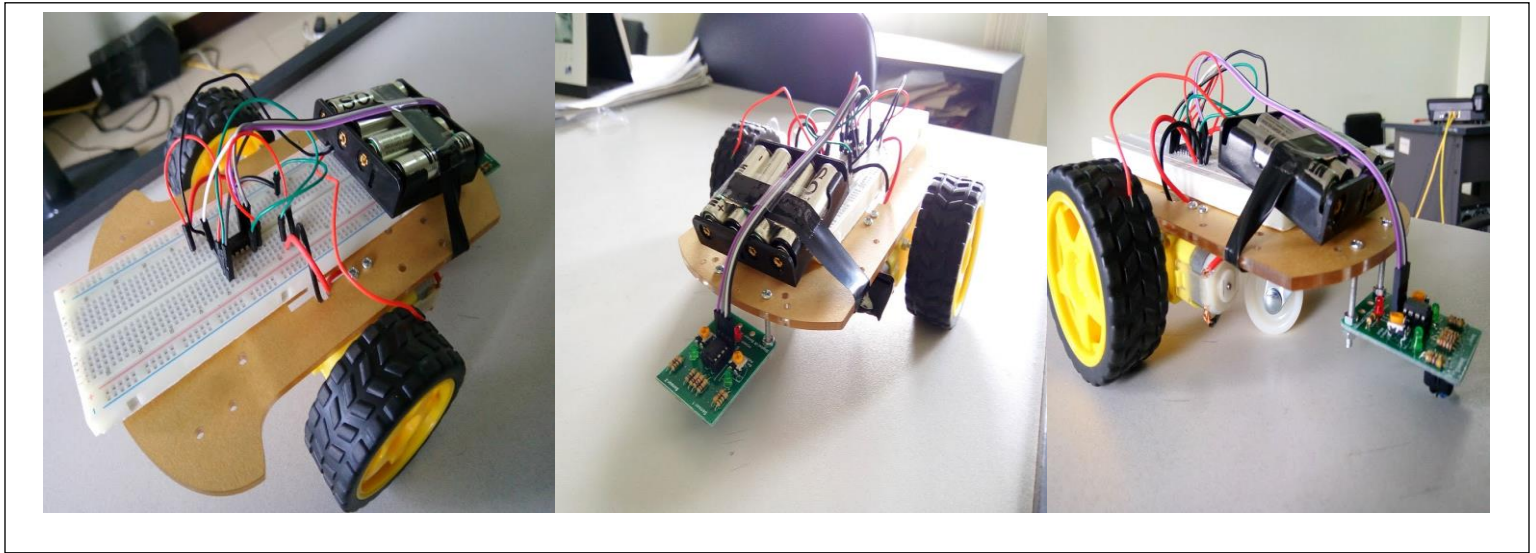

Fig. 3: The photo of Our Project



Fig. 4: Robot is moving through the black track

# **CHAPTER 3**

# **HARDWARE DESCRIPTION**

## **POWERSUPPLY:**

**Power supply** is a reference to a source of electrical power. A device or system that supplies electrical or other types of energy to an output load or group of loads is called a **power supply unit** or **PSU**. The term is most commonly applied to electrical energy supplies, less often to mechanical ones, and rarely to others.

Here in our application we need a 9v DC power supply for all electronics involved in the project. This requires step down transformer, rectifier, voltage regulator, and filter circuit for generation of 5v DC power.



Fig 5. 9V Battery and 4 AA Battery

For our project we have used one 9V battery and 4 AA battery.

## **Robotic Chassis(2 Wheel with DC Motor):**

This robotic chassis kit contains of an acrylic base with two gear motors, two compatible wheels, a ball caster, and other accessories.

## **Package Contains:**

- 2 x Rubber wires
- 2 x Deceleration motors

- 2 x Aluminum fasteners
- 1 x Nylon all-direction wheel
- 1 x Chassis
- 1 x Battery box (4 x AA batteries, not included)
- 1 x Screwdriver



Fig. 6 Robotic Chassis

### **DC motor specification:**

- Rated Voltage: 3-6V DC.
- Unloaded speed: 120 RPM.
- Load current: 190 mA (250 mA MAX).
- Maximum torque: 800 g. Cm min.
- Chassis Specification:
  - Dimensions: 7.72 in x 4.13 in x 0.12 in (19.6 cm x 10.5 cm x 0.3 cm)
  - Weight: 14.29 oz (405 g)

### **Wheel specification:**

- Width:30mm
- Diameter:65mm

## **ULN 2003 IC:**

These are high voltage, high current Darlington arrays each containing seven open collector Darlington pairs with common emitters. Each channel rated at 500mA and can withstand peak currents of 600mA. Suppression diodes are included for inductive load driving and the inputs are pinned opposite the outputs to simplify board layout. It features common-cathode Flyback diodes for switching inductive loads.

### **Features:**

The ULN2003 is known for its high-current, high-voltage capacity. The drivers can be paralleled for even higher current output. Even further, stacking one chip on top of another, both electrically and physically, has been done. Generally it can also be used for interfacing with a stepper motor, where the motor requires high ratings which cannot be provided by other interfacing devices.



Fig. 7 IC ULN2003



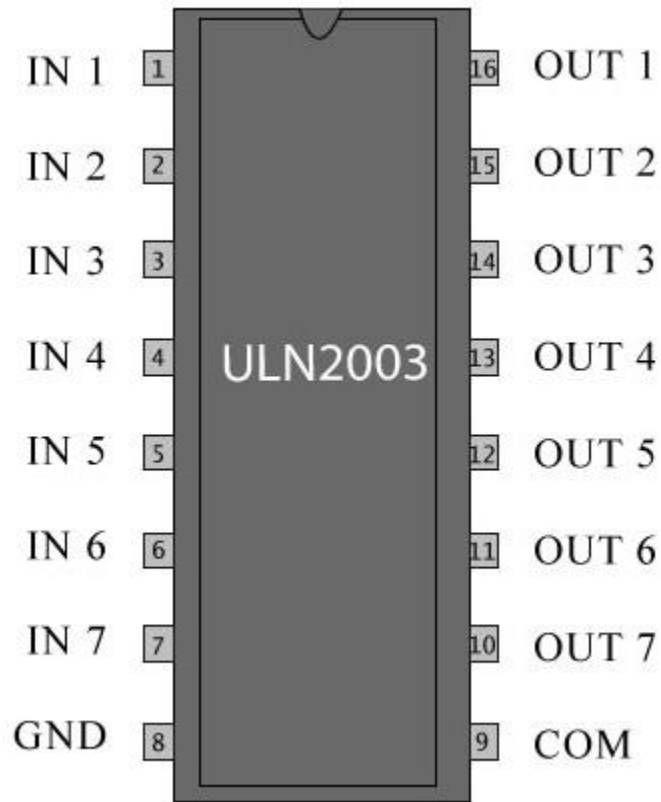

Fig. 8 Schematic View of IC ULN2003

**Main specifications:**

- 500 mA rated collector current (single output)
- 50 V output (there is a version that supports 100 V output)
- Includes output flyback diodes
- Inputs compatible with TTL and 5-V CMOS logic.

**Applications:**

Typical usage of the ULN2003A is in driver circuits for relays, lamp and LED displays, stepper motors, logic buffers and line drivers.

## Digital IR Sensor Array2

This sensor package is for line following Bot. Every now and then hobbyist who are willing to play with Line following Robot has tough time with the IR sensor arrangement. This is a neat solution for them. Two TCRT5000 reflective optical sensors have been used here. The LM358 dual works as a comparator with two reference voltages set by four POTs. The sensors have 0.5 inch spacing.



Fig. 9 2 Array IR Sensors

Calibration: To calibrate the sensors, we had to tune the respective POTs. The left POT is connected to SEN1 and the right POT is connected to SEN2. We have connected VCC and GND pins with the power supply and connect SEN1 and SEN2 pins with two LEDs. We have kept tuning the POTs until the LEDs glow. Then we have drawn a black line on a white paper. After the proper calibration is done, the LEDs will turn on when the sensors trace black and they will turn off when the Sensors trace white. That means, the output is always either 1 (High) or 0 (Low).

Inside view of the sensor is:

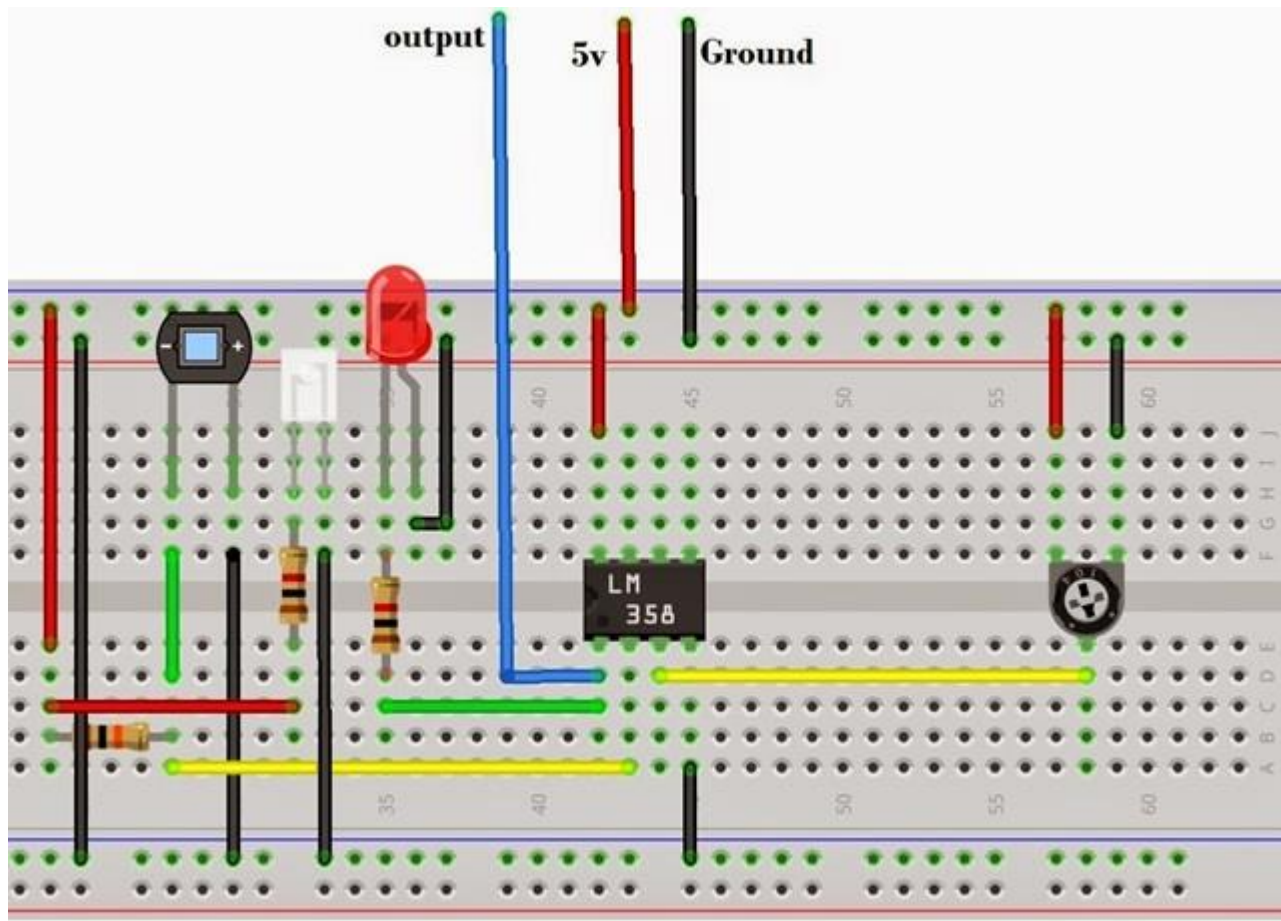

Fig. 10 Inside view of the IR Sensors

## **Breadboard:**

A breadboard is a construction base for prototyping of electronics. Originally it was literally a bread board, a polished piece of wood used for slicing bread. In the 1970s the solderless breadboard (AKA plugboard, a terminal array board) became available and nowadays the term "breadboard" is commonly used to refer to these. "Breadboard" is also a synonym for "prototype".

Because the solderless breadboard does not require soldering, it is reusable. This makes it easy to use for creating temporary prototypes and experimenting with circuit design. For this reason, solderless breadboards are also extremely popular with students and in technological education. Older breadboard types did not have this property. A stripboard (veroboard) and similar prototyping printed circuit boards, which are used to build semi-permanent soldered prototypes or one-offs, cannot easily be reused. A

variety of electronic systems may be prototyped by using breadboards, from small analog and digital circuits to complete central processing units (CPUs). This project board for experimental, non-soldered setup of electronic circuits.



Fig.11 Breadboard

### **LEDs:**

A light-emitting diode (LED) is a two-lead semiconductor light source. It is a p–n junction diode, which emits light when activated. When a suitable voltage is applied to the leads, electrons are able to recombine with electron holes within the device, releasing energy in the form of photons. This effect is called electroluminescence, and the color of the light (corresponding to the energy of the photon) is determined by the energy band gap of the semiconductor.



Fig. 12 LED

## **Features:**

- High luminous intensity output.
- Low power consumption.
- High efficiency.
- Versatile mounting on PCB or panel.
- I.C. Compatible/low current requirement.
- Reliable and rugged.

## **Applications:**

- Status indicator.
- Backlighting front panels.
- Light pipe sources.
- Lighted switches.

## **Specification:**

- Diameter:5mm
- Forward Voltage :2.0V
- Forward Current:20mA

## **Breadboard Jumper Wire Set:**



Fig. 13 Jumper wires

This set of jumper wires can help remove the clutter on breadboard. It comes in 14 different lengths and 8 colors to keep circuit on the surface. All of them are pre-formed and pre-sorted. We can easily find the color and length that need within a sec.

### **Battery Snap:**

Probably the easiest way to connect our DC LEDs to power is using a 9V battery, with these nice long battery snaps. As you can see from this photo, the battery snap is designed to snap onto the leads on the terminal end of any standard 9V battery. These battery straps have two leads, a red "positive" wire and a black "negative" wire. Each of our pre-wired LEDs also come with a red positive wire and a black negative wire.



Fig. 14 Battery Snap

**CHAPTER 4**  
**WORKING**  
**PRINCIPLES**

Concept of working of line follower is related to light. We use here the behavior of light at black and white surface. When light fall on a white surface it is almost full reflected and in case of black surface light is completely absorbed. This behavior of light is used in building a line follower robot.

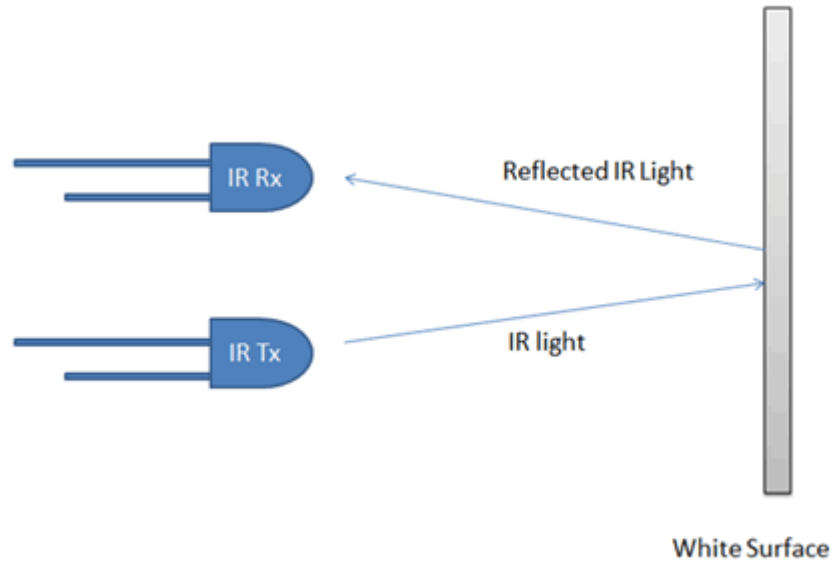

Fig. 15 Working principle of the Sensors

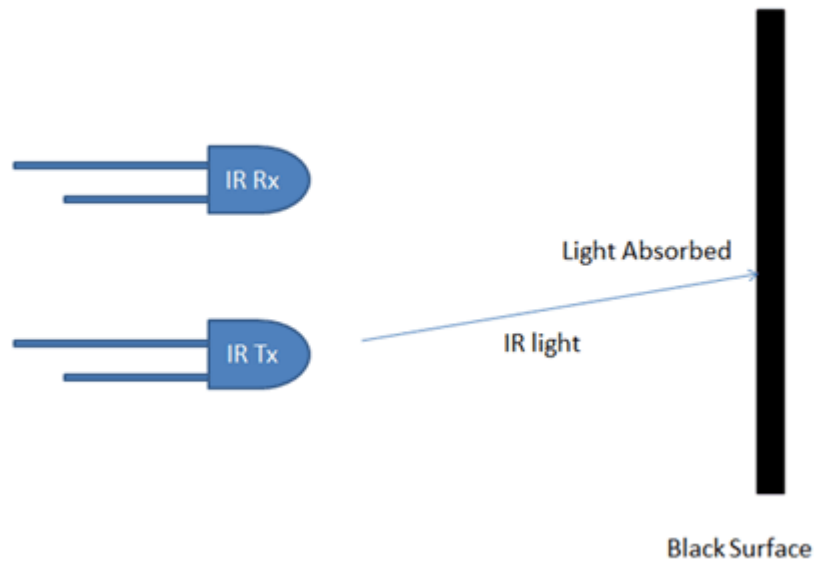

Fig. 16 Working principle of the Sensors



In this **line follower robot** we have used IR Transmitters and IR receivers also called photo diodes. They are used for sending and receiving light. IR transmits infrared lights. When infrared rays falls on white surface, it's reflected back and catch by photodiodes which generates some voltage changes. When IR light falls on a black surface, light is absorb by the black surface and no rays are reflected back, thus photo diode does not receive any light or rays.

Here in this line follower robot when sensor senses white surface then IC gets 1 as input and when senses black line IC gets 0 as input.

## Circuit Explanation

The whole line follower robot can be divided into 3 sections: sensor section, control section and driver section.

### **Sensor section:**

This section contains 2Array IR Sensors which includes IR diodes, potentiometer, Comparator (Op-Amp) and LED's. Potentiometer is used for setting reference voltage at comparator's one terminal and IR sensors are used to sense the line and provide a change in voltage at comparator's second terminal. Then comparator compares both voltages and generates a digital signal at output. Here in this **line follower circuit** we have used two comparator for two sensors. LM 358 is used as comparator. LM358 has inbuilt two low noise Op-amps.

### **Control Section:**

IC ULN2003 is used for controlling whole the process of line follower robot. This IC reads these signals and send commands to driver circuit to drive line follower.

### **Driver section:**

Driver section consists motor driver and two DC motors. Motor driver is used for driving motors. So we add a motor driver circuit to get enough voltage and current for motor. IC ULN 2003 sends commands to this motor driver and then it drive motors.

Here in this project we are using two IR sensor modules namely left sensor and right sensor. When both left and right sensor senses white then robot move forward.

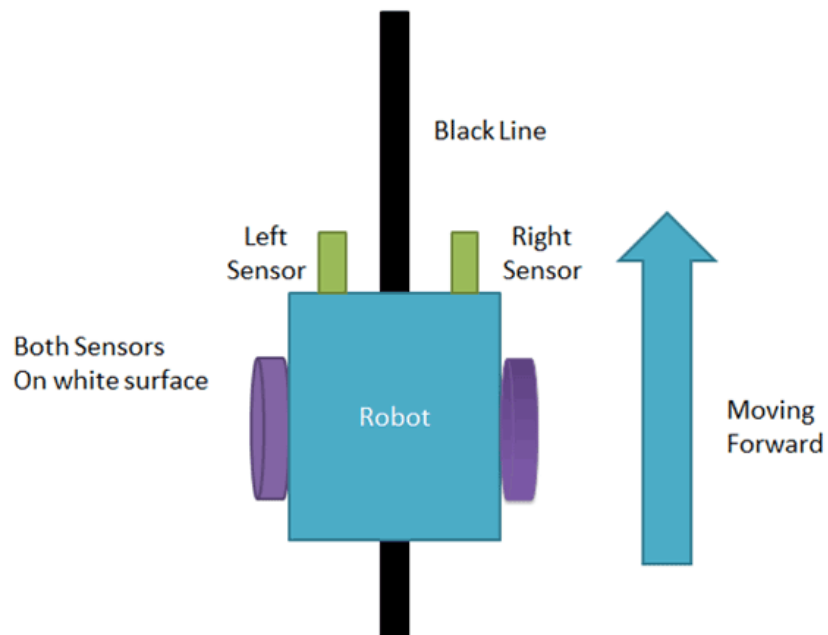

Fig. 17 Line following principle of the robot

If left sensor comes on black line then robot turn left side.

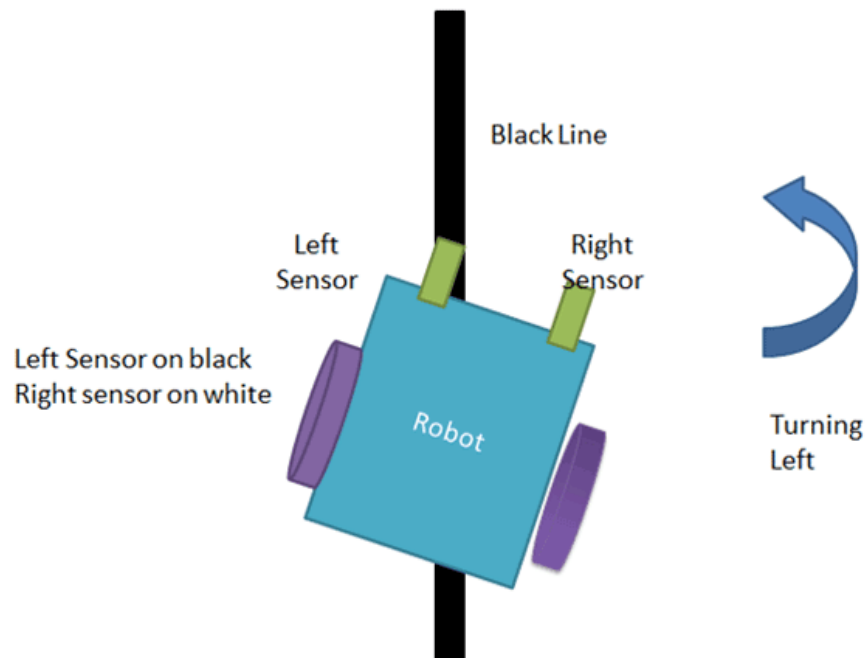

Fig. 18 Line following principle of the robot

If right sensor sense black line then robot turn right side until both sensor comes at white surface. When white surface comes robot starts moving on forward again.

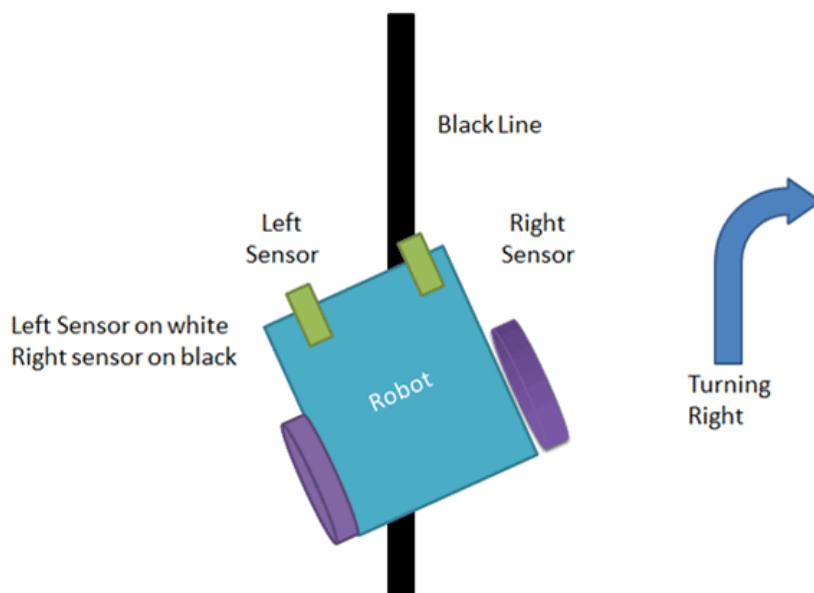

Fig. 19 Line following principle of the robot

If both sensors comes on black line, robot stops.

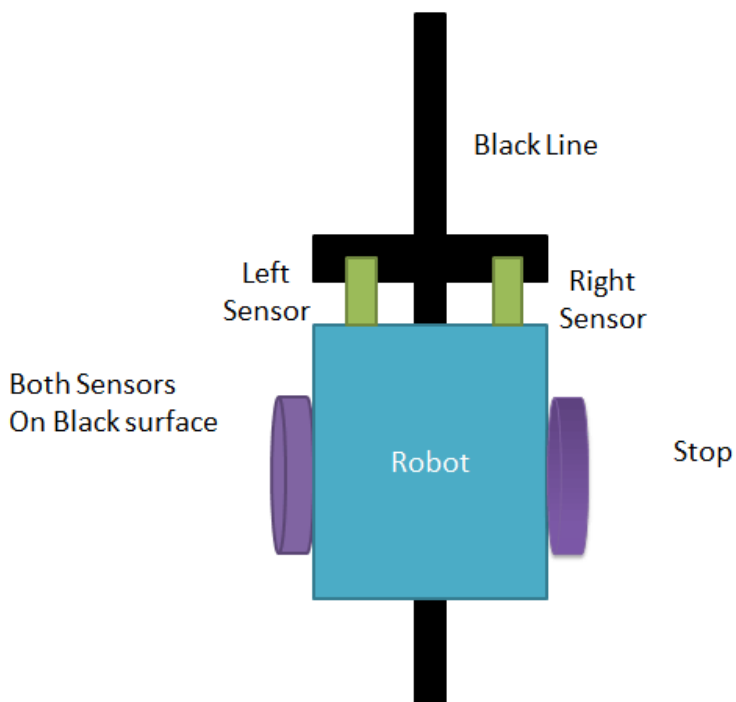

Fig. 20 Line following principle of the robot

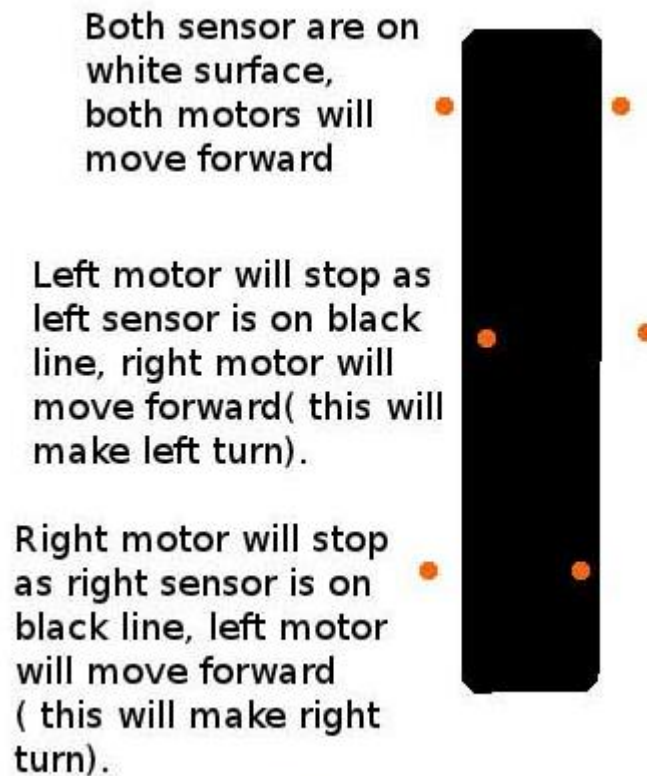

Fig. 21 Line following principle of the robot

Whenever the IR sensor falls on a reflective surface or white surface it starts to give 5v as output.

ULN 2003A is a high-voltage, high- current, Darlington transistor array. In this circuit it act as a switch , whenever it receives 5v as input , the output switch opens. if there is no input, switch closes. Whenever IR sensor produces 5v as output, the output pin of IR sensor is connected with the input pin of ULN 2003 IC, so the motor starts to run, if there is no output, the motor stops.

## Track For LINE FOLLOWING ROBOT:

We can use any track for the robot. The following we have used. We had to make sure that the black line should be opaque and the surface be transparent.



Fig. 22 Line Track for the robot

**CHAPTER 5**  
**APPLICATIONS**

- Line followers can be used to deliver mail within an office building
- It can be used to deliver medications in a hospital.
- The technology has been suggested for running buses and other mass transit systems ,and may end up as part of autonomous cars navigating the freeway.
- The line follower can be used in guidance system for industrial robots moving on shop floor. An example might be in a warehouse where the robots follow 'tracks' to and from the shelves they stock and retrieve from.
- A line follower robot can be used in military as spy kids or in many other applications.

**CHAPTER 6**  
**FURTHER**  
**IMPROVEMENTS**



The line follower robot is made by op-amps and transistors, where the motor is directly on or off using the signal of the comparator. Now the techniques can be replaced by PWM using more sensor, microcontroller and H-Bridge motor controller IC i.e. L293D. Also instead of LDR it can be used phototransistor whose response is much better than LDR. There are 2 line sensors used here so the fluctuation of line is a fact. Using more than 2 sensor likely 5 sensor array may be used to detect the black line quickly. Also using microcontroller it can draw the reverse direction as well as obstacle avoiding turning the motor 180°. The block diagram may be represented as follows. Also using color sensors the robot can sense different colors. It can be used in the robotic game competition and other fields.

So the development features in brief:

- Applying PWM technique
- Use of Microcontroller
- Use of color sensor.

# **CHAPTER 7**

# **CONCLUSION**

In this project, we have designed a line following robot. This robot does not need any remote controller or any controller like Bluetooth, Wi-Fi, GSM, driver etc, it will run automatically with following a line. We have not used any microcontroller. This robot is very low cost but very effective for various purposes. Our project can be used in various sectors like in medicine delivering in hospitals, delivering products in any places, spying, and surveillance and so on. In future we can add several sensors, cameras etc to get more features.

# **REFERENCES:**

- [1] S. E. M. Bajestani and A. Vosoughinia, "Technical report of building a line follower robot," Electronics and Information Engineering (ICEIE), 2010 International Conference On, Kyoto, 2010, pp. V1-1-V1-5.
- [2] Colak, I., Yildirim, D., "Evolving a Line Following Robot to use in shopping centers for entertainment", Industrial Electronics, 2009. IECON '09. 35th Annual Conference of IEEE, pp.3803 - 3807, 3-5 Nov. 2009.
- [3] ULN 2003A Data Sheet.
- [4] Data sheets of IR sensors.
- [5] Pakdaman, M.; Sanaatiyan, M.M., "Design and Implementation of Line Follower Robot," Computer and Electrical Engineering, 2009. ICCEE '09. Second International Conference on , vol.2, no., pp.585-590, 28-30 Dec. 2009.
- [6] [www.wikipedia.com](http://www.wikipedia.com)
- [7] M. ZafriBaharuddin, Izham Z. Abidin, S. SulaimanKajaMohideen, Yap KeemSiah, Jeffrey Tan Too Chuan, "Analysis of Line Sensor Configuration for the Advanced Line Follower Robot", University Tenaga Nasional.
- [8] Nor Maniha Abdul Ghani, FaradilaNaim, Tan PiowYon , "Two Wheels Balancing Robot with Line Following Capability," World Academy of Science, Engineering and Technology, pp-634-638, 2011.