

© Faculty of Sciences and Engineering, East West University

Automatic Room Light Control Using Bidirectional Visitor Counter and Gas Detection

Project Submitted by:

Mahmud Hossain Jewel

ID: 2013-1-53-013

Md.Nazmul Islam

ID: 2013-2-55-027

Md. Jahid Hasan

ID: 2013-2-55-021

Under the Supervision of

Dr. Md. Habibur Rahman

Professor

Department of Electrical and Electronic Engineering,

Faculty of Engineering and Technology

University of Dhaka

**Department of
Electronics and Communications Engineering
Faculty of Sciences and Engineering**

Mahmud Hossain Jewel | Jahid Hasan | Nazmul Islam

August , 2017



East West University

Automatic Room Light Control Using Bidirectional Visitor Counter and Gas Detection

A Project submitted to the Electronics and Communications Engineering Department, Faculty of Sciences and Engineering, East West University in partial fulfillment of the requirements for the degree of **Bachelor of Science in Electronics and Telecommunication Engineering**.

Mahmud Hossain Jewel

ID:2013-1-53-013

Md. Jahid Hasan

ID:2013-2-55-021

Md.Nazmul Islam

ID:2013-2-55-027

**Department of
Electronics and Communications Engineering
Faculty of Sciences and Engineering
Semester Summer-2017
August, 2017**



East West University

DECLARATION

This is to certify that the project “Automatic Room Light Control Using Bidirectional Visitor Counter and Gas Detection” is our original work. No part of this work is being submitted anywhere else partially or fully for the award of any degree or diploma. Any material reproduced in this project, has been properly acknowledged.

Students Names & Signatures

Mahmud Hossain Jewel

Md. Nazmul Islam

Md. Jahid Hasan

APPROVAL

The project titled - “Automatic Room Light Control Using Bidirectional Visitor Counter and Gas Detection” prepared by the following students has been submitted to the following respective members of the board of examiners of the Electronics and Communications Engineering Department of Sciences and Engineering Faculty, East West University in partial fulfillment of the requirements for the degree of **Bachelor of Science in Electronics and Telecommunication Engineering**. The project has been accepted on August, 2017 as satisfactory.

Md. Mahmud Hossain Jewel

ID:2013-1-53-013

Md.Nazmul Islam

ID:2013-2-55-027

Md. Jahid Hasan

ID:2013-2-55-021

Dr. Md. Habibur Rahman

Professor

Department of

Electrical and Electronics Engineering

Faculty of Engineering and Technology

University of Dhaka

Dr. M. Mofazzal Hossain

Professor & Chairperson

Department of

Electronics and Communications

Engineering

Faculty of Sciences and Engineering

East West University

CONTENTS

ACKNOWLEDGEMENT	9
ABSTRACT.....	10
1.CHAPTER ONE.....	11
1.0 INTRODUCTION.....	11
1.1 OBJECTIVE OF THE PROJECT.....	11
1.2 LITERATURE REVIEW.....	12
1.3 PROJECT REPORT ORGANIZATION.....	13
2.CHAPTER TWO.....	15
2.0 THEORIES AND MODELS RELEVANT TO THE DESIGN.....	15
2.1 LIST OF COMPONENTS.....	15
2.2 ARDUINO MEGA.....	15
2.3 ATmega1280.....	21
2.4 MQ-2 SENSOR BASED SMOKE DETECTOR.....	23
3.CHAPTER THREE.....	26
3.0 SYSTEM COMPONENTS DESCRIPTION.....	26
3.1 THE RESISTOR.....	26
3.2 THE DIODE.....	27
3.3 THE TRANSISTOR.....	30
3.4 THE TRANSISTOR AS A STATIC SWITCH.....	32.
3.5 THE LASER DIODE.....	33

3.6	16x2 LCD DISPLAY.....	37
3.7	PHOTODIODE.....	39
3.8	.RELAY.....	42
4.	CHAPTER FOUR.....	44
4.0	SYSTEM DESIGN AND DEVELOPMENT.....	44
4.1	INTRODUCTION.....	44
4.2	HARWARE DESIGN.....	45
4.3	COMPONENTS USED IN THE SYSTEM.....	46
4.4	SENSING UNIT.....	46
4.5	16x2 LCD DISPLAY CONNECTION WITH ARDUINO.....	48
4.6	CONNECTION TO LOAD WITH POWER SUPPLY.....	49
4.7	SOFTWARE DESIGN.....	51
4.8	INSTALLING THE ARDUINO.....	51
4.9	VERIFYING THE HARDWARE.....	51
4.10	ARDUINO LANGUAGE.....	51
4.11	LOGICAL DIAGRAM.....	52
5.	CHAPTER FIVE.....	55
5.0	SYSTEM IMPLEMENTATION AND DEVELOPMENT.....	55
5.1	TESTING.....	55
5.2	DISPLAY TESTING.....	55
5.3	SENSOR TESTING.....	56
5.4	SMOKE SENSOR TESTING.....	57

5.5 DEVELOPMENT OF THE WHOLE SYSTEM.....	58
5.6 TEST RESULTS.....	59
6.CHAPTER SIX.....	60
6.1 CONCLUSION.....	60
6.2 FUTURE WORK SCOPE.....	60
APPENDIX	
PROGRAMMING CODE OF GAS DETECTION FOR TESTING.....	61
PROGRAMMING CODE OF COUNT OF TESTING.....	61
COMBINATION OF ALL PROGRAMMING CODE.....	63
REFERENCES.....	65

ACKNOWLEDGEMENT

At first, we utter our deepest gratitude to the almighty Allah, whose boundless mercy made the completion of the project.

We are very much happy that we have taken efforts. However, it would not be possible on our part to complete it without the kind support and help of many individuals and organization. We would like to express our gratitude towards all of them.

We are grateful to our supervisor Professor **Dr. Md. Habibur Rahman** for his continuous guidance and supervision, and also for providing us the necessary information and equipment needed for the project. We highly appreciate his time and encouragement that helps us to complete this project. We would like to express our special thanks to the Department Chair Professor **Dr. M. Mofazzal Hossain**.

Our appreciation also goes to our beloved **East West University** for providing us the opportunities to prove ourselves.

Mahmud Hossain Jewel

Md.Nazmul Islam

Md. Jahid Hasan

ABSTRACT

As a developing country power sources of Bangladesh are limited. We know, a major part of our electricity is being wasted due to our incognizance. After leaving the room the fans, lights etc. remain on unnecessarily. The main object of this project is to minimize the wastage of electricity. The other objective of this project is to detect the gas or smoke level in kitchen room and take necessary action to protect firing. When a person enters into the room, the load will get power and can be run by their switches. The counter circuit can count the number of persons staying in the room. If a person enters into the room the counter will be incremented and if a person leaves the room the counter will be decremented. After the last person leaving the room the value of the counter will be zero and the load will be disconnected from the power. The gas sensor always senses the gas or smoke level in the kitchen room. If the level of gas/smoke is above a predefined threshold, it will give an alarm sound. Moreover, if there is no person in the room the power main switch will be automatically OFF. But if there is someone inside the room it will only give the alarm so that the person can take necessary action. Arduino board has been used in this project as a control circuit. Two laser diodes and two photodiodes work as person counter and a gas sensor unit have been used. The project has been completed and tested. It works properly and its performance is satisfactory.

CHAPTER ONE

Introduction

1.0 INTRODUCTION

The need for a device that can automatically control the lightening system of a room and capability of taking count of number of people in a room and sensing of smoke on its own has been long overdue. Fire outbreaks that occur in various homes originate when the occupant are either sleeping or not even at home at all. In big environments such as petrochemical industries, whenever there is fire outbreak, it turns out to be so fierce that people run away for the sake of their lives.

1.1 OBJECTIVE OF THE PROJECT

Wastage of electricity is one of the main problems which we are facing now-a-days. In our home, school, colleges or industry we see that fan and lighting point are kept on even if there are nobody in the room or area and passage. This happens due to negligence or because we forgot to turn lights off or we are in a hurry. To avoid all such situations this project called “Automatic room light controller with visitor counter and gas sensing” is designed. This project has three modules, first one is known as “Digital Visitor counter” and second module is known as “Automatic room light controller” and third one is “smoke detection”. Main concept behind this project is known as “Visitor counter” which measures the number of persons entering in any room like seminar hall, conference room, hotel rooms. This function is implemented using laser diode and photodiode. Here Arduino receives the signals from the sensors, and this signal is operated under the control of software which is stored in the ROM.

LCD display placed outside the room displays this value of person count. This person count will be incremented if somebody enters inside the room and at that time lights are turned on. And in reverse way, person count will be decremented if somebody leaves the room. When number of

persons inside the room is zero, lights inside the room are turned off. Another objective of this project is to design a circuit useful for detecting smoke and activating an alarm.

1.2 LITERATURE REVIEW

Although not same but many related work have been done by many researchers. Some of the papers have been studied and described below.

Asha Rawat, et al. [2016] has done an “Automated Room Light Controller with Visitor Counter”^[1]. The main purpose of the project is automation, saving electricity, increasing appliance life span and yet providing a desired output smartly.

Subhankar Chatteraj , Aditya Chakraborty et al [2016] has done a “Bidirectional Visitor Counter with Automatic Room Light Controller and Arduino as the master controller”^[2]. This paper gives the basic idea of how to control the bidirectional visitor counter and room light counter using Arduino Mega and Ardiono(IDE). The cost of this technology is very economical.

Sonali K. Pawar et al [2016] has done a “AUTOMATIC ROOM LIGHT CONTROLLER USING MICROCONTROLLER AND VISITOR COUNTER ”^[3]. This digital world Technology is very advanced and we prefer things to be done automatically without any human efforts. This project also helps to reduce human efforts. Also it is very useful to conserve resources.

E.Shilpa et al[2017] has done a” Implementation of Automatic Room Light Controller with Visitor Counter Design using 8051 Microcontroller”^[4]. This project compacts with the usage of the energy in this competitive world of electricity. This project is well-organized enough to let someone know about the accuracy of the person entered and have taken the exit from the room.

D.Hari Priya et al [2014] has done a “Gas Leakage System”^[5]. The heart of this paper here is a LPG gas leakage sensor circuit that detects the outflow of LPG gas and the circuit is a gas sensor module SEN 1327. QM 6 gas sensor is used in the SEN 1327 module.

Kausik Sen et al[2015] has done a “ Automated Fire Detection and Controlling System”^[6]. In this paper basically a low cost fire detection and control system based on smoke and heat

detection is proposed. It is comprised of a combination of electrical/electronic devices/equipments working together to detect the presence of fire and alert people through audio or visual medium after detection.

Winfred Adjardjah et al[2016] has done “Design and Construction of a Bidirectional Digital Visitor Counter”^[7]. This paper presents the design and construction of a digital bidirectional visitor counter (DBVC). The DBVC is a reliable circuit that takes over the task of counting number of persons / visitors in the room very accurately and beeps a warning alarm when the number of visitors exceeds the capacity limit of the auditorium/hall.

Gaurav Waradkaret al [2016] has done “Automated Room Light Controller with Visitor Counter”^[8]. This paper presents the design and construction of a digital bidirectional visitor counter . This is reliable project that takes over the task of counting number of visitors in the room.

Kimbley et al[2016]has done “AUTOMATIC ROOM LIGHT CONTROLLER USING MICROCONTROLLER AND VISITOR COUNTER ”^[9]. The Project ‘Automatic Room Light Controller Using microcontroller ATMEGA16A and bidirectional visitor counter’ controls a room light as well as count the number of individuals entering and leaving a room. When an individual enters into a room then one counter is incremented by one and one light in a room will be switched ON and when the individuals leaves a room then the counter is decremented by one.

Sibu Skaria et al [2014]has done a “Automatic Lighting Controller”^[10]. Based on the paper title, “AUTOMATIC LIGHTING CONTROLLER”, controls the amount of lighting in a room by constantly monitoring the level of luminance in a room. Lights are then controlled such that required illumination is available in the room. It can be applied effectively in commercial buildings, homes, colleges etc.

1.3 PROJECT REPORT ORGANIZATION

Chapter 1 serves as the introductory chapter and Theory literature review where we try to relay the concept and acceptable reasons why the project should be implemented for the intending user of the work.

Chapter 2 deals with the Related of all possible related or closely related work of the design. The evolutionary trend in automatic room light controller operations and design, specification will also be looked at. The use and importance of this project design will also be mentioned here. It will be looking at the best place where this project design can be use and where it cannot. This chapter will also make room for adding additional information on past works in the area that will help in the actualization of this project design.

Chapter 3 treats system component description of this project design. It comprises of the information gathering, the source of the materials used in designing and writing the project report. The components and devices used in the course of designing this project will be analyzed to know their basic means of operation and how they will help in putting up this design, system design approach; the possible way to tackled the project design from scratch, bottom-up; it will treat how the practical detail was gotten before considering about the general principle of the system design, choice of design system; it focuses on why the project design was done using a microcontroller rather than using only digital logic.

In chapter 4, it presents the detail design work and discusses the system, test carried out, Expected results, and Performance evaluation. The schematic diagram of the design and the source code (in C language) used in programming the microcontroller were also outlined.

Summary and conclusion of the design will be presented in Chapter 5. It will be looking at the problems encountered in designing the project and possible solutions to them. From the problems and solutions of this work, the suggestion for further improvement will be stated.

CHAPTER TWO

Related Theory

2.0 THEORIES AND MODELS RELEVANT TO THE DESIGN

2.1 List of Components:

Following is the list of components that are necessary to build the assembly the project.

- Arduino Mega board
- Voltage comparator(LM339)
- 16x2 LCD display
- Laser diode
- Photodiode
- Transister(C828)
- Resistors
- Zener diode
- LED
- Preset(variable resistor) – 10k Ω
- Computer with Arduino software installed

The system designed was based on fundamental and principles of electromagnetism, electronic devices, interfacing, intelligent control systems, and software systems.

2.2 Arduino Mega

The Arduino Mega is a microcontroller board based on the ATmega1280 ([datasheet](#)). It has 54 digital input/output pins (of which 14 can be used as PWM outputs), 16 analog inputs,

4 UARTs (hardware serial ports), a 16 MHz crystal oscillator, a USB connection, a power jack, an ICSP header, and a reset button. It contains everything needed to support the microcontroller; simply connect it to a computer with a USB cable or power it with a AC-to-DC adapter or battery to get started. The Mega is compatible with most shields designed for the Arduino Duemilanove or Diecimila.

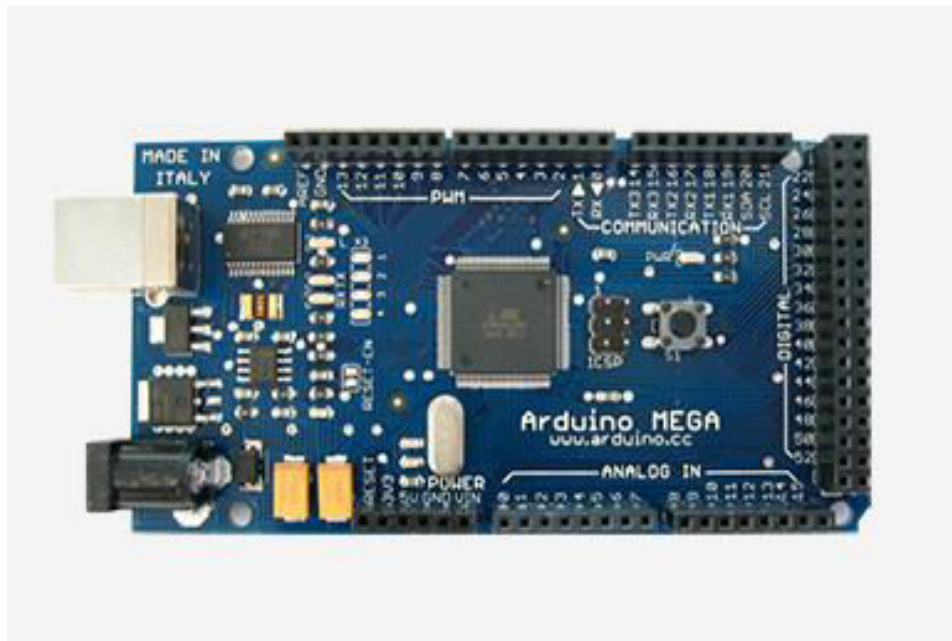

Figure 2.1: Arduino Mega

Summary

Microcontroller	ATmega1280
Operating Voltage	5V
Input Voltage (recommended)	7-12V
Input Voltage (limits)	6-20V
Digital I/O Pins	54 (of which 15 provide PWM output)
Analog Input Pins	16
DC Current per I/O Pin	40 mA
DC Current for 3.3V Pin	50 mA
Flash Memory	128 KB of which 4 KB used by boot loader
SRAM	8 KB

EEPROM	4 KB
Clock Speed	16 MHz

Power

The Arduino Mega can be powered via the USB connection or with an external power supply. The power source is selected automatically.

External (non-USB) power can come either from an AC-to-DC adapter (wall-wart) or battery. The adapter can be connected by plugging a 2.1mm center-positive plug into the board's power jack. Leads from a battery can be inserted in the Gnd and Vin pin headers of the POWER connector.

The board can operate on an external supply of 6 to 20 volts. If supplied with less than 7V, however, the 5V pin may supply less than five volts and the board may be unstable. If using more than 12V, the voltage regulator may overheat and damage the board. The recommended range is 7 to 12 volts.

The power pins are as follows:

- VIN. The input voltage to the Arduino board when it's using an external power source (as opposed to 5 volts from the USB connection or other regulated power source). You can supply voltage through this pin, or, if supplying voltage via the power jack, access it through this pin.
- 5V. The regulated power supply used to power the microcontroller and other components on the board. This can come either from VIN via an on-board regulator, or be supplied by USB or another regulated 5V supply.
- 3V3. A 3.3 volt supply generated by the on-board FTDI chip. Maximum current draw is 50 mA.
- GND. Ground pins.

Memory

The ATmega1280 has 128 KB of flash memory for storing code (of which 4 KB is used for the bootloader), 8 KB of SRAM and 4 KB of EEPROM (which can be read and written with the EEPROM library).

Input and Output

Each of the 54 digital pins on the Mega can be used as an input or output, using pin Mode functions. They operate at 5 volts. Each pin can provide `digitalWrite()`, `digitalWrite()`, and `digitalRead()` or receive a maximum of 40 mA and has an internal pull-up resistor (disconnected by default) of 20-50 kOhms. In addition, some pins have specialized functions:

- **Serial:** 0 (RX) and 1 (TX);
- **Serial 1:** 19 (RX) and 18 (TX);
- **Serial 2:** 17 (RX) and 16 (TX);
- **Serial 3:** 15 (RX) and 14 (TX). Used to receive (RX) and transmit (TX) TTL serial data. Pins 0 and 1 are also connected to the corresponding pins of the FTDI USB-to-TTL Serial chip.
- **External Interrupts:** 2 (interrupt 0), 3 (interrupt 1), 18 (interrupt 5), 19 (interrupt 4), 20 (interrupt 3), and 21 (interrupt 2). These pins can be configured to trigger an interrupt on a low value, a rising or falling edge, or a change in value. See the `attachInterrupt()` function for details.
- **PWM:** 2 to 13 and 44 to 46. Provide 8-bit PWM output with the `analogWrite()` function.
- **SPI:** 50 (MISO), 51 (MOSI), 52 (SCK), 53 (SS). These pins support SPI communication, which, although provided by the underlying hardware, is not currently included in the Arduino language. The SPI pins are also broken out on the ICSP header, which is physically compatible with the Duemilanove and Diecimila.
- **LED:** 13. There is a built-in LED connected to digital pin 13. When the pin is HIGH value, the LED is on, when the pin is LOW, it's off.

- **I²C:** 20 (SDA) and 21 (SCL). Support I²C (TWI) communication using the Wire library (documentation on the Wiring website). Note that these pins are not in the same location as the I²C pins on the Duemilanove or Diecimila.
- The Mega has 16 analog inputs, each of which provide 10 bits of resolution (i.e. 1024 different values). By default they measure from ground to 5 volts, though it is possible to change the upper end of their range using the AREF pin and analog Reference() function.

There are a couple of other pins on the board:

- **AREF:** Reference voltage for the analog inputs. Used with analog Reference().
- **Reset:** Bring this line LOW to reset the microcontroller. Typically used to add a reset button to shields which block the one on the board.

Communication

The Arduino Mega has a number of facilities for communicating with a computer, another Arduino, or other microcontrollers. The ATmega1280 provides four hardware UARTs for TTL (5V) serial communication. An FTDI FT232RL on the board channels one of these over USB and the FTDI drivers (included with the Arduino software) provide a virtual com port to software on the computer. The Arduino software includes a serial monitor which allows simple textual data to be sent to and from the Arduino board. The RX and TX LEDs on the board will flash when data is being transmitted via the FTDI chip and USB connection to the computer (but not for serial communication on pins 0 and 1).

A SoftwareSerial library allows for serial communication on any of the Mega's digital pins. The ATmega1280 also supports I2C (TWI) and SPI communication. The Arduino software includes a Wire library to simplify use of the I2C bus; see the documentation on the Wiring website for details. To use the SPI communication, please see the ATmega1280 datasheet.

Automatic (Software) Reset

Rather than requiring a physical press of the reset button before an upload, the Arduino Mega is designed in a way that allows it to be reset by software running on a connected computer. One of

the hardware flow control lines (DTR) of the FT232RL is connected to the reset line of the ATmega1280 via a 100 nanofarad capacitor. When this line is asserted (taken low), the reset line drops long enough to reset the chip. The Arduino software uses this capability to allow you to upload code by simply pressing the upload button in the Arduino environment. This means that the bootloader can have a shorter timeout, as the lowering of DTR can be well-coordinated with the start of the upload.

This setup has other implications. When the Mega is connected to either a computer running Mac OS X or Linux, it resets each time a connection is made to it from software (via USB). For the following half-second or so, the bootloader is running on the Mega. While it is programmed to ignore malformed data (i.e. anything besides an upload of new code), it will intercept the first few bytes of data sent to the board after a connection is opened. If a sketch running on the board receives one-time configuration or other data when it first starts, make sure that the software with which it communicates waits a second after opening the connection and before sending this data.

The Mega contains a trace that can be cut to disable the auto-reset. The pads on either side of the trace can be soldered together to re-enable it. It's labeled "RESET-EN". You may also be able to disable the auto-reset by connecting a 110 ohm resistor from 5V to the reset line; see this forum thread for details.

USB Over current Protection

The Arduino Mega has a resettable polyfuse that protects your computer's USB ports from shorts and overcurrent. Although most computers provide their own internal protection, the fuse provides an extra layer of protection. If more than 500 mA is applied to the USB port, the fuse will automatically break the connection until the short or overload is removed.

Physical Characteristics and Shield Compatibility

The maximum length and width of the Mega PCB are 4 and 2.1 inches respectively, with the USB connector and power jack extending beyond the former dimension. Three screw holes allow the board to be attached to a surface or case. Note that the distance between digital pins 7 and 8 is 160 mil (0.16"), not an even multiple of the 100 mil spacing of the other pins.

The Mega is designed to be compatible with most shields designed for the Diecimila or Duemilanove. Digital pins 0 to 13 (and the adjacent AREF and GND pins), analog inputs 0 to 5, the power header, and ICSP header are all in equivalent locations. Further the main UART (serial port) is located on the same pins (0 and 1), as are external interrupts 0 and 1 (pins 2 and 3 respectively). SPI is available through the ICSP header on both the Mega and Duemilanove / Diecimila. *Please note that I²C is not located on the same pins on the Mega (20 and 21) as the Duemilanove / Diecimila (analog inputs 4 and 5).*

2.3 ATmega1280

The high-performance, low-power Microchip 8-bit AVR RISC-based microcontroller combines 128KB ISP flash memory, 8KB SRAM, 4KB EEPROM, 86 general purpose I/O lines, 32 general purpose working registers, real time counter, six flexible timer/counters with compare modes, PWM, 4 USARTs, byte oriented 2-wire serial interface, 16-channel 10-bit A/D converter, and a JTAG interface for on-chip debugging. The device achieves a throughput of 16 MIPS at 16 MHz and operates between 2.7-5.5 volts.

By executing powerful instructions in a single clock cycle, the device achieves a throughput approaching 1 MIPS per MHz, balancing power consumption and processing speed.



Figure 2.2: ATmega1280

Parameter Name	Value
Program Memory Type	Flash
Program Memory (KB)	128
CPU Speed (MIPS)	16
RAM Bytes	8
Data EEPROM (bytes)	4096
Digital Communication Peripherals	4-UART, 5-SPI, 1-I2C
Capture/Compare/PWM Peripherals	4 Input Capture, 4 CCP, 16PWM
Comparators	1
Temperature Range (C)	-40 to 85
Operating Voltage Range (V)	1.8 to 5.5
Pin Count	100
Cap Touch Channels	1

2.4 MQ2 SENSOR-BASED SMOKE DETECTOR

The MQ 2 sensor belongs to the MQ series Semiconductor Gas Sensors.

The MQ sensor find application in gas leak and smoke detection application. Their major advantageous features include:

- High sensitivity
- Fast response
- Wide detection range
- Stable performance and long life
- Simple drive circuit
- MQ2 is the most suitable and readily available for smoke detection.

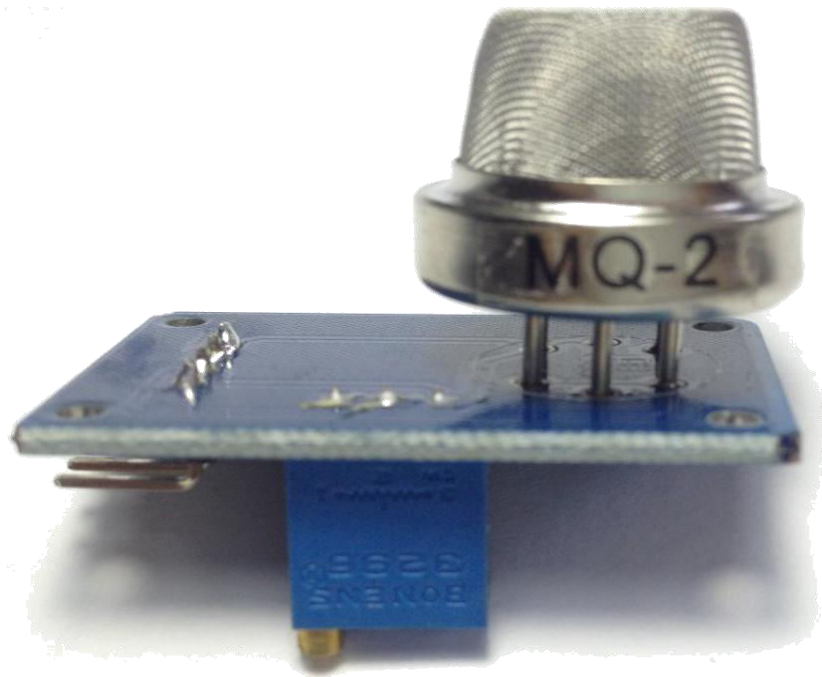

Figure 2.3: MQ-2 sensor

MQ2 is a flammable gas and smoke sensor which detects the concentrations of combustible gas in the air and outputs reading as an analog voltage. It is sensitive to a wide range of gases and are used at room temperature.

Some modules have a built-in variable resistor to adjust the sensitivity of the sensor.

It falls under the category of electromechanical gas detectors which work by allowing gases to diffuse through a porous membrane to an electrode where it is either chemically oxidized or reduced. The amount of current produced is determined by how much of the gas is oxidized at the electrode, indicating concentration of the gas. However, this type of sensors is subject to corrosive elements or chemical contamination and may last only 1-2 years before a replacement is required.

For MQ2, the sensitive material used is SnO_2 , whose conductivity is lower in clean air. Its conductivity increases as the concentration of combustible gases increases.

Pin Wiring

The MQ-2 sensor has 4 pins.

Pin-----Wiring to Arduino

A0-----Analog pins

D0-----Digital pins

GND-----GND

VCC-----5V

So, before jumping into the coding part, let's check whether we've assembled all the necessary hardware components.

CHAPTER THREE

SYSTEM COMPONENT DESCRIPTION

3.0 The components used are described below

3.1 The Resistor

A resistor is a device that restricts the flow of electricity. It opposes the flow of current. Resistors can limit or divide the current, reduce the voltage, protect an electric circuit, or provide large amount of heat or light. Its unit is ohm. Alternatively, ohm can be defined as the resistance of a circuit in which a current of 1 ampere generates heat at a rate of 1 watt. If V represents the potential difference in volts across the circuit having resistance R ohm, carrying a current in amperes, the relationship is thus;

$$V = IR \dots\dots\dots (1)$$

$$\text{Hence, } R = V/I \dots\dots\dots (2)$$

Where; R is resistance

V is voltage I is current (amperes)

Resistors can be connected either in series or parallel in an electrical circuit. When resistors are connected in series, their combined resistance is equal to the sum individual resistors connected together. The values of resistors are normally shown using colour bands. Each of the colour represents a number shown in the table below.

COLOR	NUMBER REPRESENTATION
BLACK	0
BROWN	1
RED	2
ORANGE	3
YELLOW	4
GREEN	5
BLUE	6
VIOLET	7
GREY	8
WHITE	9

Table 3.1: Resistor Color Code

3.2 The Diodes

A diode is a two-terminal electronic component that conducts electric current in only one direction. The term usually refers to a semiconductor diode, the most common type today. This is a crystalline piece of semiconductor material connected to two electrical terminals. A vacuum

tube diode (now little used except in some high-power technologies) is a vacuum tube with two electrodes: a plate and a cathode.

The most common function of a diode is to allow an electric current to pass in one direction (i.e. the forward direction being that it is forward biased) while blocking current in the opposite direction (i.e. the reverse direction). Thus, the diode can be thought as an electronic version of a check valve. This unidirectional behavior is called rectification and is used in converting an alternating current to a direct current and to extract modulation from radio signal to radio receivers.

However, diode can have more complicated behavior than this simple on-off action.

This is due to their complex non-linear electrical characteristics, which can be tailored by varying the construction of their p-n junction .these are exploited in special purpose diode that performs many different function .For example ,specialized diode are used as voltage regulators (zener diode),to electronically tune radio as TV receives (Varactor diode),to generate radio frequency oscillation (tunnel diode),and to produce light (light emitting diodes).Tunnel diodes exhibit negative resistance ,which makes them useful in some types of circuits .diode were the first semiconductor electronic devices .

A few schematic symbols for diode are



Figure 3.1: (a) Junction Diode (b) Zener Diode (c) Light Emitting Diode

The first diode in fig 2.7 is a light emitting diode (LED) which is a diode formed a direct band-gap semiconductor ,such as gallium arsenide ,carriers that cross the junction emit photons when they recombine with the majority carrier on the other side .depending on the material wavelength (or colors)from the infrared to the near ultraviolet may be produced. The forward potential of these diode depends on the wavelength of the emitted photon: 1.2 v corresponds to red, 2.4 v to violet .The first LED were red and yellow and higher frequency diodes have been developed over time. All LED produce incoherent ,narrow-spectrum light “white “LED are actually combination of three LEDS of different colour ,or a blue LED with a yellow scintillated coating. LEDs can also be used as low –efficiency photodiodes in signal applications .A LED may be paired with a photodiode or phototransistor in the same package, to form an Opto-isolator.

The second of diodes in the schematic is the varactor or tuning diode .depicted here is actually two varactor diode mounted back to back with the dc control voltage applied at the common junction of the cathodes .these cathodes have the double bar appearance of capacitor to indicate a Varactor diode .when a D.C control voltage is applied to the common junction of the cathode, the capacitance exhibited by the diode (all diode and transistor exhibit some degree of capacitance) will vary in accordance with the applied voltage .

The third of the diodes is a Zener diode, which is fairly popular for the voltage regulation of low current power supplies .whilst to obtain high current Zener diode most regulation today is done electronically with the use of dedicated integrated circuits and pass transistors.

Finally a semiconductor diode could be a small signal diode of the type 1N914 type commonly used in switching applications, a rectifying diode of the 1N4001 type or even one of the high power, high current stud mounting type .you will notice the straight bar end has the letter “K” this donate the cathode while the “A” denotes anode .current can only flow from the anode to the cathode and not in reverse direction hence the “arrow” appearance .This is one importance characteristics of diodes.

3.3 The Transistor

A transistor is a semiconductor device used to amplify and switch electronic signals .it is made of a solid piece of semiconductor material, with at least three terminals for connection to external circuit. A voltage or current applied to one pair of the transistor terminal changes the current through another pair of terminals. Because the controlled(output) power can be much more than the controlling (input)power, the transistor provides amplification of a signal .they are used in a Varsity of circuits and you will you will find that it is rare that a circuit built in a school technology department does not contain one transistor. They are central to electronics and there are two types; NPN and PNP

Transistor circuit symbol



Figure 3.2 (a)PNP TRANSISTORS (b) NPN TRANSISTORS

The advantages of transistors are:

- Small size and minimal weight allowing the development of miniaturized electronic devices
- Highly automated manufacturing process resulting in low per unit cost
No warm up period for cathode heaters required after power application
Lower power dissipation and generally greater energy efficiency.
- Extremely long life .some transistorized devices have been in service for more than 50 years
- Insensitivity to mechanical shock and vibration, thus avoiding the problems of micro phonics in audio applications.

Some limitations are:

- Silicon transistors does not operate at voltage higher than about 1000volts (SiC devices can be operated as high as high 3000 volts).In contrast electron tubes have been developed that can be operated at ten thousands of volts
- High power, high frequency operation, such as that used in over the air television broadcasting is better achieved in electron tubes due to improved electron mobility in a vacuum.
- Silicon transistors are much more vulnerable than electron tubes to an electromagnetic pulse generated by a high-altitude nuclear explosion.

3.4 Transistor as a Static Switch

The bipolar transistor is the commonly used switch in digital electronic circuits .It is a three-terminal semiconductor component that allows an input signal at one of its terminal to cause the other two terminals to become short or an open circuit .the transistors is most commonly made of silicon that has been altered into N-type material and P-type materials. N-type silicon is made by bombarding pure silicon with atoms having structures with one more electrons that the silicon does. The P-type silicon is made by bombarding pure silicon with atoms having structures with one less electron than silicon does.

Three distinct region makes up a bipolar transistor: emitter, base and collector .they can be a combination of N-P-N type material or P-N-P type material bounded together as a three dimensional device .the figure below shows the physical layout and symbol for an N-P-N transistor .In a PNP transistor, the emitter arrow point the other way.

In an electronic circuit, the input signal (0 or 1) is usually applied to the base of the transistor, which causes the collection –emitter junction to become a short or an open circuit .The rules of transistor switching are as follows:

In an NPN transistor, applying a positive voltage from base to emitter causes the collector –to-emitter junction to short (this is called ‘turning the transistor ON’)

Applying a negative voltage or 0V from the base to the emitter causes the collector –to-emitter junction to open (this is called turning the transistor OFF”).

In a PNP transistor, applying a negative voltage from the base to emitter turns it ON. Applying a positive voltage or 0v from base to emitter turns it OFF.

3.5 LASER Diode:

A laser diode is electrically a P-i-n diode. The active region of the laser diode is in the intrinsic (I) region, and the carriers (electrons and holes) are pumped into that region from the N and P regions respectively. While initial diode laser research was conducted on simple P-N diodes, all modern lasers use the double-heterostructure implementation, where the carriers and the photons are confined in order to maximize their chances for recombination and light generation. Unlike a regular diode, the goal for a laser diode is to recombine all carriers in the I region, and produce light. Thus, laser diodes are fabricated using direct bandgap semiconductors. The laser diode epitaxial structure is grown using one of the crystal growth techniques, usually starting from an N doped substrate, and growing the I doped active layer, followed by the P doped cladding, and a contact layer. The active layer most often consists of quantum wells, which provide lower threshold current and higher efficiency.

Laser diodes form a subset of the larger classification of semiconductor p-n junction diodes. Forward electrical bias across the laser diode causes the two species of charge carrier – holes and electrons – to be "injected" from opposite sides of the p-n junction into the depletion region. Holes are injected from the p-doped, and electrons from the n-doped, semiconductor. (A depletion region, devoid of any charge carriers, forms as a result of the difference in electrical potential between n- and p-type semiconductors wherever they are in physical contact.) Due to the use of charge injection in powering most diode lasers, this class of lasers is sometimes termed "injection lasers," or "injection laser diode" (ILD). As diode lasers are semiconductor devices, they may also be classified as semiconductor lasers. Either designation distinguishes diode lasers from solid-state lasers.

Another method of powering some diode lasers is the use of optical pumping. Optically pumped semiconductor lasers (OPSL) use a III-V semiconductor chip as the gain medium, and another laser (often another diode laser) as the pump source. OPSL offer several advantages over ILDs, particularly in wavelength selection and lack of interference from internal electrode structures. When an electron and a hole are present in the same region, they may recombine or "annihilate" producing a spontaneous emission — i.e., the electron may re-occupy the energy state of the hole, emitting a photon with energy equal to the difference between the electron's original state and hole's state. (In a conventional semiconductor junction diode, the energy 25

released from the recombination of electrons and holes is carried away as phonons, i.e., lattice vibrations, rather than as photons.) Spontaneous emission below the lasing threshold produces similar properties to an LED. Spontaneous emission is necessary to initiate laser oscillation, but it is one among several sources of inefficiency once the laser is oscillating. The difference between the photon-emitting semiconductor laser and a conventional phonon-emitting (non-light-emitting) semiconductor junction diode lies in the type of semiconductor used, one whose physical and atomic structure confers the possibility for photon emission. These photon-emitting semiconductors are the so-called "direct bandgap" semiconductors. The properties of silicon and germanium, which are single-element semiconductors, have bandgaps that do not align in the way needed to allow photon emission and are not considered "direct." Other materials, the so-called compound semiconductors, have virtually identical crystalline structures as silicon or germanium but use alternating arrangements of two different atomic species in a checkerboard-like pattern to break the symmetry. The transition between the materials in the alternating pattern creates the critical "direct bandgap" property. Gallium arsenide, indium phosphide, gallium antimonide, and gallium nitride are all examples of compound semiconductor materials that can be used to create junction diodes that emit light.

Diagram of a simple laser diode, such as shown above; not to scale

In the absence of stimulated emission (e.g., lasing) conditions, electrons and holes may coexist in proximity to one another, without recombining, for a certain time, termed the "upper-state lifetime" or "recombination time" (about a nanosecond for typical diode laser materials), before they recombine. A nearby photon with energy equal to the recombination energy can cause recombination by stimulated emission. This generates another photon of the same frequency, polarization, and phase, travelling in the same direction as the first photon. This means that stimulated emission will cause gain in an optical wave (of the correct wavelength) in the injection region, and the gain increases as the number of electrons and holes injected across the junction increases. The spontaneous and stimulated emission processes are vastly more efficient in direct bandgap semiconductors than in indirect bandgap semiconductors; therefore silicon is not a common material for laser diodes.

As in other lasers, the gain region is surrounded with an optical cavity to form a laser. In the simplest form of laser diode, an optical waveguide is made on that crystal's surface, such that the light is confined to a relatively narrow line. The two ends of the crystal are cleaved to form

perfectly smooth, parallel edges, forming a Fabry–Pérot resonator. Photons emitted into a mode of the waveguide will travel along the waveguide and be reflected several times from each end face before they exit. As a light wave passes through the cavity, it is amplified by stimulated emission, but light is also lost due to absorption and by incomplete reflection from the end facets. Finally, if there is more amplification than loss, the diode begins to "lase".

Some important properties of laser diodes are determined by the geometry of the optical cavity. Generally, the light is contained within a very thin layer, and the structure supports only a single optical mode in the direction perpendicular to the layers. In the transverse direction, if the waveguide is wide compared to the wavelength of light, then the waveguide can support 26 multiple transverse optical modes, and the laser is known as "multi-mode". These transversely multi-mode lasers are adequate in cases where one needs a very large amount of power, but not a small diffraction-limited beam; for example in printing, activating chemicals, or pumping other types of lasers.

In applications where a small focused beam is needed, the waveguide must be made narrow, on the order of the optical wavelength. This way, only a single transverse mode is supported and one ends up with a diffraction-limited beam. Such single spatial mode devices are used for optical storage, laser pointers, and fiber optics. Note that these lasers may still support multiple longitudinal modes, and thus can lase at multiple wavelengths simultaneously. The wavelength emitted is a function of the band-gap of the semiconductor material and the modes of the optical cavity. In general, the maximum gain will occur for photons with energy slightly above the band-gap energy, and the modes nearest the peak of the gain curve will lase most strongly. The width of the gain curve will determine the number of additional "side modes" that may also lase, depending on the operating conditions. Single spatial mode lasers that can support multiple longitudinal modes are called Fabry Perot (FP) lasers. An FP laser will lase at multiple cavity modes within the gain bandwidth of the lasing medium. The number of lasing modes in an FP laser is usually unstable, and can fluctuate due to changes in current or temperature.

Single spatial mode diode lasers can be designed so as to operate on a single longitudinal mode. These single frequency diode lasers exhibit a high degree of stability, and are used in spectroscopy and metrology, and as frequency references. Single frequency diode lasers classed as either distributed feedback (DFB) lasers or distributed Bragg reflector (DBR) lasers.

Due to diffraction, the beam diverges (expands) rapidly after leaving the chip, typically at 30 degrees vertically by 10 degrees laterally. A lens must be used in order to form a collimated beam like that produced by a laser pointer. If a circular beam is required, cylindrical lenses and other optics are used. For single spatial mode lasers, using symmetrical lenses, the collimated beam ends up being elliptical in shape, due to the difference in the vertical and lateral divergences. This is easily observable with a red laser pointer

.

The simple diode described above has been heavily modified in recent years to accommodate modern technology, resulting in a variety of types of laser diodes, as described below.

3.5 16x2 LCD DISPLAY:

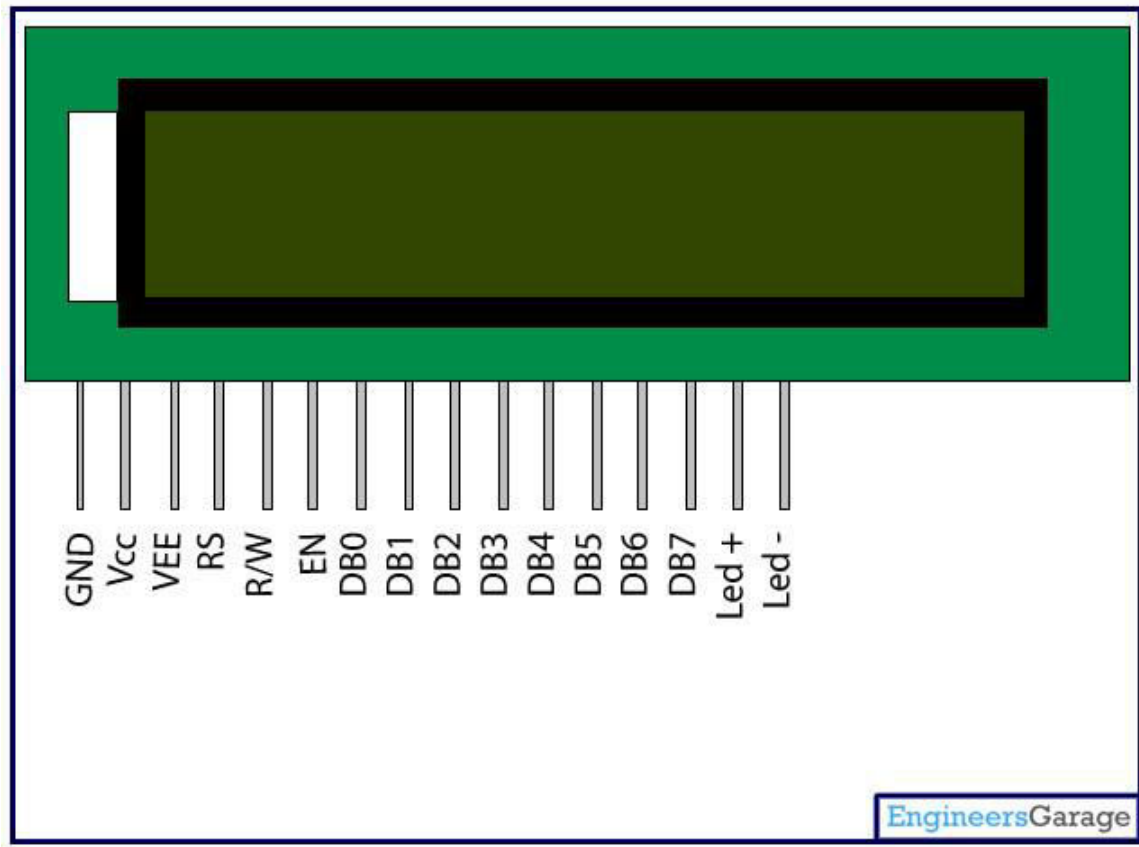

Figure 3.3: 16x2 LCD DISPLAY

LCD (Liquid Crystal Display) screen is an electronic display module and find a wide range of applications. A 16x2 LCD display is very basic module and is very commonly used in various devices and circuits. These modules are preferred over seven segments and other multi segment LEDs. The reasons being: LCDs are economical; easily programmable; have no limitation of displaying special & even custom characters (unlike in seven segments), animations and so on.

A **16x2 LCD** means it can display 16 characters per line and there are 2 such lines. In this LCD each character is displayed in 5x7 pixel matrix. This LCD has two registers, namely, Command and Data.

The command register stores the command instructions given to the LCD. A command is an instruction given to LCD to do a predefined task like initializing it, clearing its screen, setting the cursor position, controlling display etc. The data register stores the data to be displayed on the LCD. The data is the ASCII value of the character to be displayed on the LCD. Click to learn more about internal structure of a LCD.

Pin Description:

Pin No	Function	Name
1	Ground (0V)	Ground
2	Supply voltage; 5V (4.7V – 5.3V)	V _{CC}
3	Contrast adjustment; through a variable resistor	V _{EE}
4	Selects command register when low; and data register when high	Register Select
5	Low to write to the register; High to read from the register	Read/write
6	Sends data to data pins when a high to low pulse is given	Enable
7	8-bit data pins	DB0
8		DB1
9		DB2
10		DB3
11		DB4
12		DB5
13		DB6
14		DB7
15	Backlight V _{CC} (5V)	Led+
16	Backlight Ground (0V)	Led-

TABLE 3.1: PIN DESCRIPTION OF 16x2 LCD DISPLAY

3.6 Photodiode

A photodiode is a semiconductor device that converts light into current. The current is generated when photons are absorbed in the photodiode. A small amount of current is also produced when no light is present. Photodiodes may contain optical filters, built-in lenses, and may have large or small surface areas. Photodiodes usually have a slower response time as their surface area increases. The common, traditional solar cell used to generate electric solar power is a large area of photodiode.

Photodiodes are similar to regular semiconductor diodes except that they may be either exposed (to detect vacuum UV or X-rays) or packaged with a window or optical fiber connection to allow light to reach the sensitive part of the device. Many diodes designed for use specifically as a photodiode use a PIN junction rather than a p-n junction, to increase the speed of response. A photodiode is designed to operate in reverse bias.



Figure 3.4: Schematic diagram of photodiode

Principal of operation

A photodiode is a p–n junction or PIN structure. When a photon of sufficient energy strikes the diode, it creates an electron-hole pair. This mechanism is also known as the inner photoelectric effect. If the absorption occurs in the junction's depletion region, or one diffusion length away from it, these carriers are swept from the junction by the built-in electric field of the depletion region. Thus holes move toward the anode, and electrons toward the cathode, and a photocurrent is produced. The total current through the photodiode is the sum of the dark current (current that is generated in the absence of light) and the photocurrent, so the dark current must be minimized to maximize the sensitivity of the device.

Photovoltaic mode

When used in zero bias or photovoltaic mode, the flow of photocurrent out of the device is restricted and a voltage builds up. This mode exploits the photovoltaic effect, which is the basis for solar cells – a traditional solar cell is just a large area photodiode.

Photoconductive mode

In this mode the diode is often reverse biased (with the cathode driven positive with respect to the anode). This reduces the response time because the additional reverse bias increases the width of the depletion layer, which decreases the junction's capacitance. The reverse bias also 28

increases the dark current without much change in the photocurrent. For a given spectral distribution, the photocurrent is linearly proportional to the illuminance (and to the irradiance). Although this mode is faster, the photoconductive mode tends to exhibit more electronic noise. The leakage current of a good PIN diode is so low (<1 nA) that the Johnson–Nyquist noise of the load resistance in a typical circuit often dominates.

Other modes of operation

Avalanche photodiodes have a similar structure to regular photodiodes, but they are operated with much higher reverse bias. This allows each photo-generated carrier to be multiplied by avalanche breakdown, resulting in internal gain within the photodiode, which increases the effective responsivity of the device.

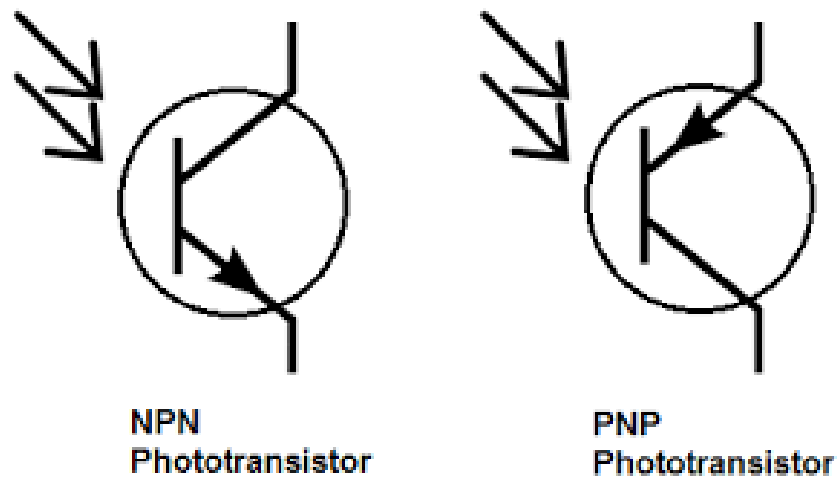

Figure 3.5: Electronic symbol for a phototransistor

A phototransistor is a light-sensitive transistor. A common type of phototransistor, called a photo bipolar transistor, is in essence a bipolar transistor encased in a transparent case so that light can reach the base–collector junction. It was invented by Dr. John N. Shive (more famous for his wave machine) at Bell Labs in 1948, ^[5]: 205 but it wasn't announced until 1950^[6]. The electrons that are generated by photons in the base–collector junction are injected into the base, and this photodiode current is amplified by the transistor's current gain β (or h_{fe}). If the emitter is left

unconnected, the phototransistor becomes a photodiode. While phototransistors have a higher responsivity for light they are not able to detect low levels of light any better than photodiodes. Phototransistors also have significantly longer response times. Field-effect phototransistors, also known as photoFETs, are light-sensitive field-effect transistors. Unlike photobipolar transistors, photoFETs control drain-source current by creating a gate voltage.

Unwanted photodiode effects

Any p–n junction, if illuminated, is potentially a photodiode. Semiconductor devices such as transistors and ICs contain p–n junctions, and will not function correctly if they are illuminated by unwanted electromagnetic radiation (light) of wavelength suitable to produce a photocurrent, this is avoided by encapsulating devices in opaque housings. If these housings are not completely opaque to high-energy radiation (ultraviolet, X-rays, gamma rays), transistors and ICs can malfunction due to induced photo-currents. Background radiation from the packaging is also significant. Radiation hardening mitigates these effects.

3.8 Relay

A relay is an electrically operated switch. Many relays use an electromagnet to mechanically operate a switch, but other operating principles are also used, such as solid-state relays. Relays are used where it is necessary to control a circuit by a separate low-power signal, or where several circuits must be controlled by one signal. The first relays were used in long distance telegraph circuits as amplifiers: they repeated the signal coming in from one circuit and re-transmitted it on another circuit. Relays were used extensively in telephone exchanges and early computers to perform logical operations.

A type of relay that can handle the high power required to directly control an electric motor or other loads is called a contactor. Solid-state relays control power circuits with no moving parts, instead using a semiconductor device to perform switching. Relays with calibrated operating characteristics and sometimes multiple operating coils are used to protect electrical circuits from overload or faults; in modern electric power systems these functions are performed by digital instruments still called "protective relays".

Magnetic latching relays require one pulse of coil power to move their contacts in one direction, and another, redirected pulse to move them back. Repeated pulses from the same input have no effect. Magnetic latching relays are useful in applications where interrupted power should not be able to transition the contacts.

Magnetic latching relays can have either single or dual coils. On a single coil device, the relay will operate in one direction when power is applied with one polarity, and will reset when the polarity is reversed. On a dual coil device, when polarized voltage is applied to the reset coil the contacts will transition. AC controlled magnetic latch relays have single coils that employ steering diodes to differentiate between operate and reset commands.

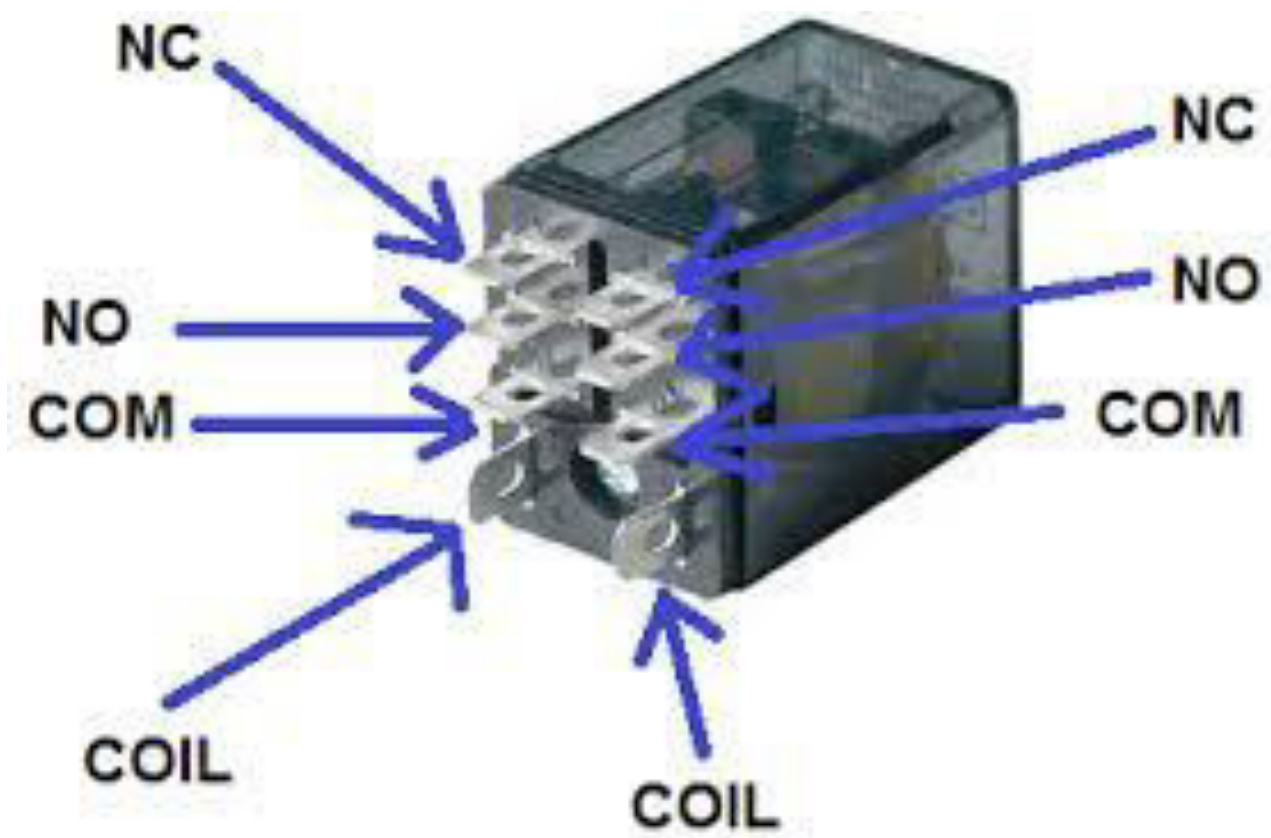

Figure3.5: Relay

Application

Relays are used wherever it is necessary to control a high power or high voltage circuit with a low power circuit, especially when galvanic isolation is desirable. The first application of relays was in long telegraph lines, where the weak signal received at an intermediate station could control a contact, regenerating the signal for further transmission. High-voltage or high-current devices can be controlled with small, low voltage wiring and pilots switches. Operators can be isolated from the high voltage circuit. Low power devices such as microprocessors can drive relays to control electrical loads beyond their direct drive capability. In an automobile, a starter relay allows the high current of the cranking motor to be controlled with small wiring and contacts in the ignition key.

Chapter 4

SYSTEM DESIGN AND DEVELOPMENT

4.1 Introduction

This project helps those people who interested to build something with Arduino. To Design a project include into two parts, one is hardware design and another part is software design. We use laser, Op-Amp, photo diode and gas sensor for the hardware design and we connected these components with microcontroller. Arduino microcontroller is more suitable for establishing a new project including robotics. Arduino software is downloaded from www.arduino.cc and C/C++ programmable language is used. Many examples are given in the ardiono.cc and this software is easy to usage.

4.2 Hardware design

The whole system design is divided into three parts to design a smart home appliance control system. First one is to design the smart system in the breadboard and control the designed system. Second part is to display part design to count the value in smart system. And third Finally, the smart home appliance control system is formed a complete integrated system. In this project Arduino development board is more efficient.

4.2.1 Full Circuit Design

The whole system consists of many sub-systems. The block diagram of the whole system is given the Figure 4.1.

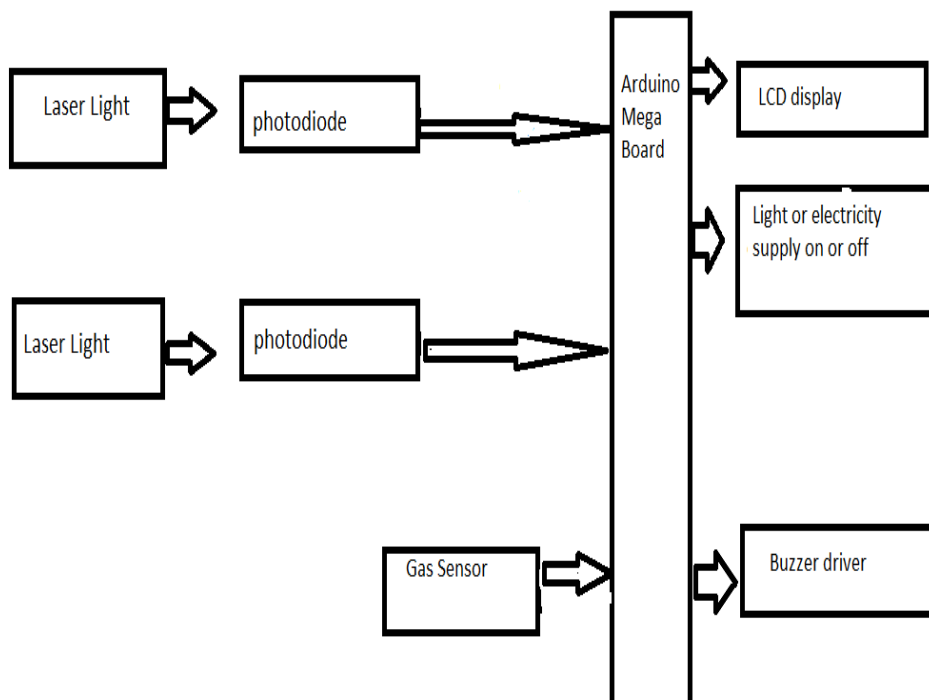

Figure 4.1: Full View of Control System

Mainly we use three major components for designing a full control system. The photodiode is receiving signal from laser light and it is connected to the arduino. The LCD display is connected

to the Arduino board and also the gas sensor are connected to the arduino board. The output of this circuit is connected to Light or electric load of a room

4.3 Components Used in the System

To design the project we use following component:

One Arduino mega Board

Two bread board

MQ-2 smoke sensor

Two photo diode

Two C828 Transmitter

Zener diode

One LCD display

1k Resistance

Variable resistance

Two Laser light

4.4 Sensing Unit

We use photodiode for receiving the laser light. It converts the light signal into current. When light falls on the junction, a reverse current flow which is proportional to the illuminance. The linear response to light makes it an element in useful photo detectors for some applications.

The photodiode is operated under a moderate reverse bias. This keeps the depletion layer free of any carriers and normally no current will flow. However when the light photon enters the intrinsic region it can strike an atom in the crystal lattice and dislodge an electron. In this way a hole-electron pair is generated. The hole and electron will then migrate in opposite directions under the action of the electric field across the intrinsic region and a small current can be seen to flow. It is found that the size of the current is proportional to the amount of light entering the intrinsic region. The more light, the greater the numbers of hole electron pairs that are generated and the greater the current flowing.

Photodiodes are just exposed PN or PIN junctions. Reverse biasing means there is an electric field over the junction. When a photon of sufficient energy hits the junction and is absorbed, this creates a free electron-hole pair which is accelerated towards the anode/cathode by the electric field, thus creating current.

Visible light is coincidentally well-suited to this kind of operation, because the absorptive of most semiconductors is fairly high in the visible region, while the required energy to excite an electron beyond the band gap voltage is 0.6-1eV, which is exactly the amount of energy contained in a just-infrared photon (1200-1400nm).

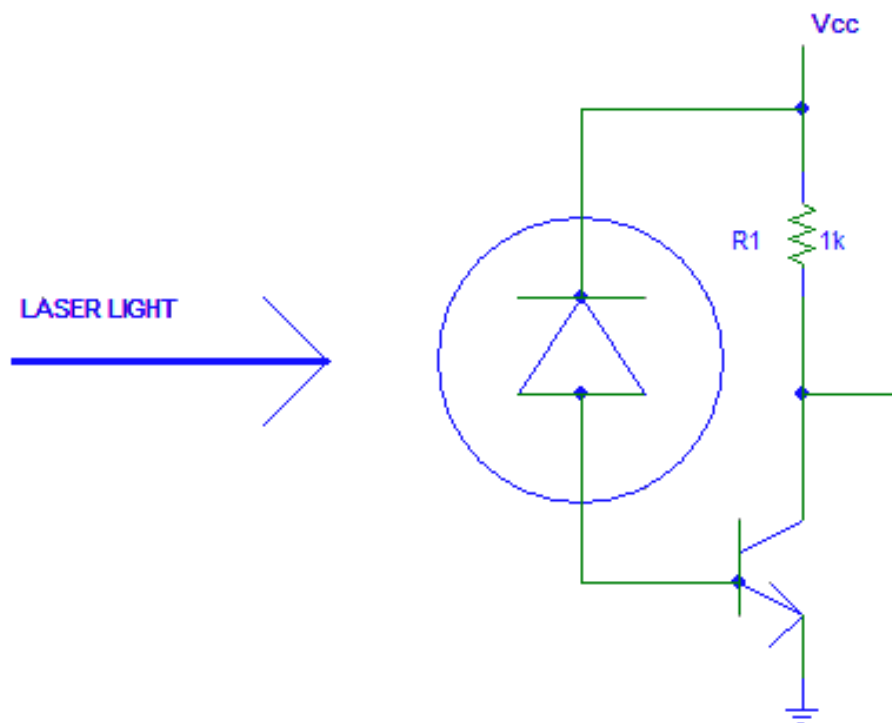

Figure 4.2: Circuit diagram of the photodiode and amplifier

The negative pin of the photo diode is connected to base of the C828 transistor. The positive pin of the photodiode is connected to 5V and connected to collector of the transistor. The Emitter is connected to the ground. The output of this circuit is out from the collector. Then the output is connected to the arduino.

4.5 16×2 LCD Display connections with Arduino Mega:

We use 16 x 2 LCD and that have a parallel interface, meaning that the microcontroller has to manipulate several interface pins at once to control the display. We can select the data register, which holds what goes on the screen. A Read/ Write (R/W) pin that selects reading mode or writing mode.

The Enable pin that enables writing to the registers .The 8 data pins (D0 -D7). The states of these pins (high or low) are the bits that we writing to a register. There's also a display contrast pin (Vo), power supply pins (+5V and Ground)and LED Backlight (Bklt+ and BKlt-) pins that web use to power the LCD, control the display contrast, and turn on and off the LED backlight, respectively.

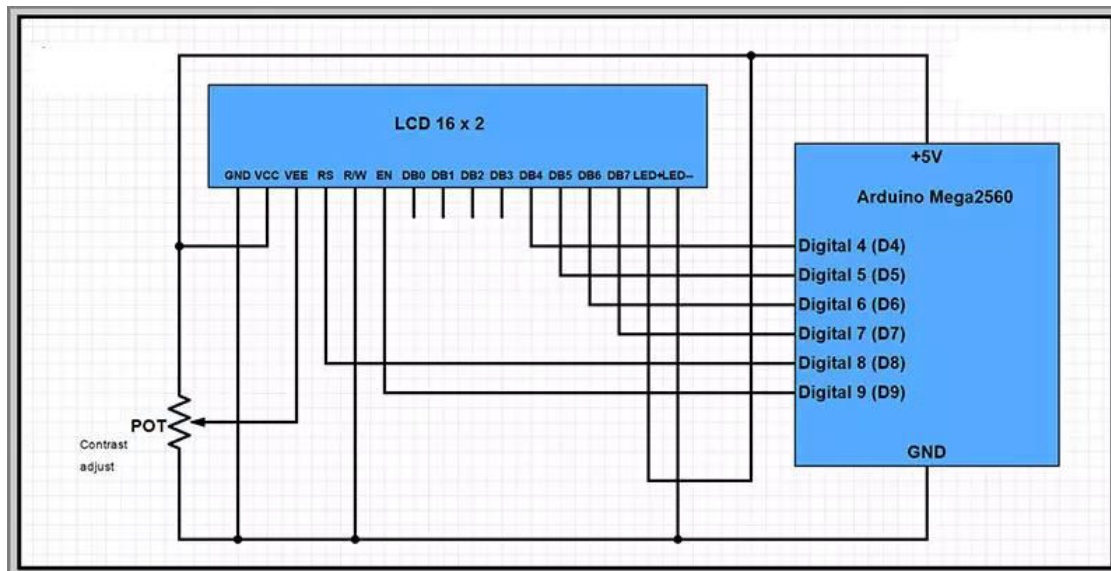

Figure 4.3: 16×2 LCD Display connections with Arduino Mega

We connect the LCD pins with Arduino in following steps:

Pin 1 is connected to Arduino GND

Pin 2 is connected to Arduino 5V

Pin 3 is connected to wiper (this is the middle pin of the 10k potentiometer)

Pin 4 is connected to Arduino pin 12

Pin 5 is connected to Arduino GND

Pin 6 is connected to Arduino pin 11

Pin 11 is connected to Arduino pin 5

Pin 12 is connected to Arduino pin 4

Pin 13 is connected to Arduino pin 3

Pin 14 is connected to Arduino pin 2

Because we will only be writing, pin 5 will be dropped to ground to show that there will be no reading. For we use the backlight, connect LCD pin 16 to GND and LCD pin 15 to +4.2V. Connect one side of the potentiometer to Arduino GND, the opposite to Arduino 5v, and the center to LCD pin 3. The pin 7, 8,9,10 are not used in the Arduino.

4.6 Connection to Load with Power Source

We use 12V Relay for connect a light or electricity supply of a room. The main operation of a relay comes in places where only a low-power signal can be used to control a circuit. It is also used in places where only one signal can be used to control a lot of circuits. The high end applications of relays require high power to be driven by electric motors. Relays are called contactors.

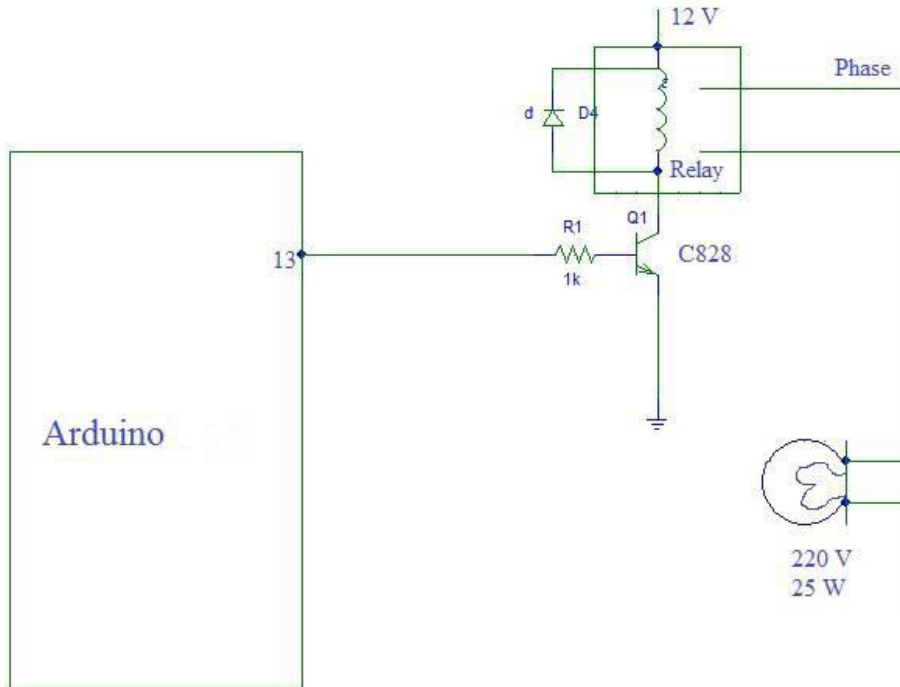

Figure 4.4: Connection of Load and Relay

We connect Arduino pin 13 with transistor's base. The emitter is connected to ground and the collector is connected to relay and diode. The relay and diode are connected parallelly. The two terminals of a relay operate as a switch. When the contacts are 'in contact' then the current flows from Terminal to Terminal. There are two types of contacts, the NO and the NC. NO stands for Normal Open contact, while NC stands for Normal Closed contact. The Normal Open is a contact like the one showed in the previous illustration. When the contacts is still, then no current flows through it (because it is an OPEN circuit). On the other hand, a Normal Closed contact allows the current to flow when the contact is still. The NC contact is turned upside-down compared to the NO contact. This way, both contacts (NO and NC) will change state if a force is applied to the left metal heading from UP to DOWN. The device that forces the terminal to move is actually an electromagnet. A coil is placed right under the contact. When current is flown through this coil, magnetism is created. This magnetism can overcome the force of the spring and can pull the contact towards it, thus it changes its position. And due to the fact that the contact is usually a small piece of metal not capable to be pulled by the electromagnet, another piece of metal is

attached to the common. The other side of relay is connected to bulb or electricity supply of a room. We need 12V power supply.

4.7 Software design

Software design is divided into two parts. First we write the Arduino program in Arduino software. Then we compile it to the Arduino hardware. This Arduino command is control the Arduino hardware and other circuit and display connection.

4.8 Installing Arduino

Arduino runs on Windows. Go to the Arduino software web site at <http://arduino.cc/en/Main/Software> and download the version of the software compatible with our system. We use Arduino 1.0.5 version.

4.9 Verifying the Hardware

Now that we have the Arduino IDE software installed, let's connect the computer to the mc board, load a small program, and verify that all components are working together. First, need to connect the USB cable to our mc board and then plug the other end of the USB cable into our computer.

4.10 Arduino Language

The Arduino language is implemented in C/C++ and based in Wiring. When we write an Arduino sketch, we are implicitly making use of the Wiring library, which is included with the Arduino IDE. This allows us to make run able programs by using only two functions: setup () and loop (). As mentioned, the Wiring language is inspired by Processing, and the Arduino language structure is inherited from the Processing language, where the equivalent functions are called setup (). We

need to include both functions in every Arduino program, even if we don't need one of them. Let's analyze the structure of a simple Arduino sketch using again the Blink example.

4.11 Logical Diagram

We have two logical diagrams for this project. First when enters the room and 2nd for exits the room.

Flow chart when person enter the room:

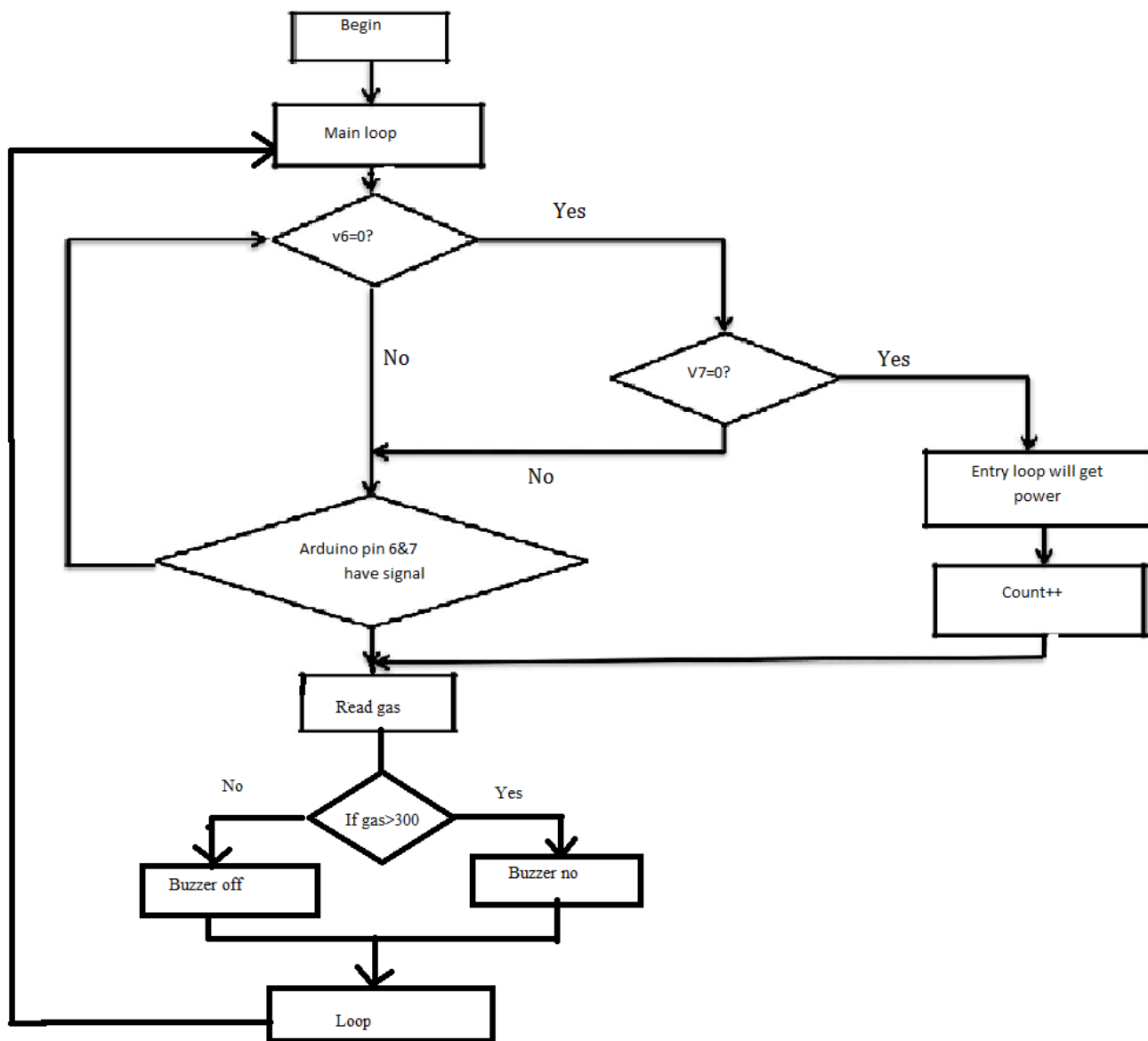

Flow chart when parson exit for room:

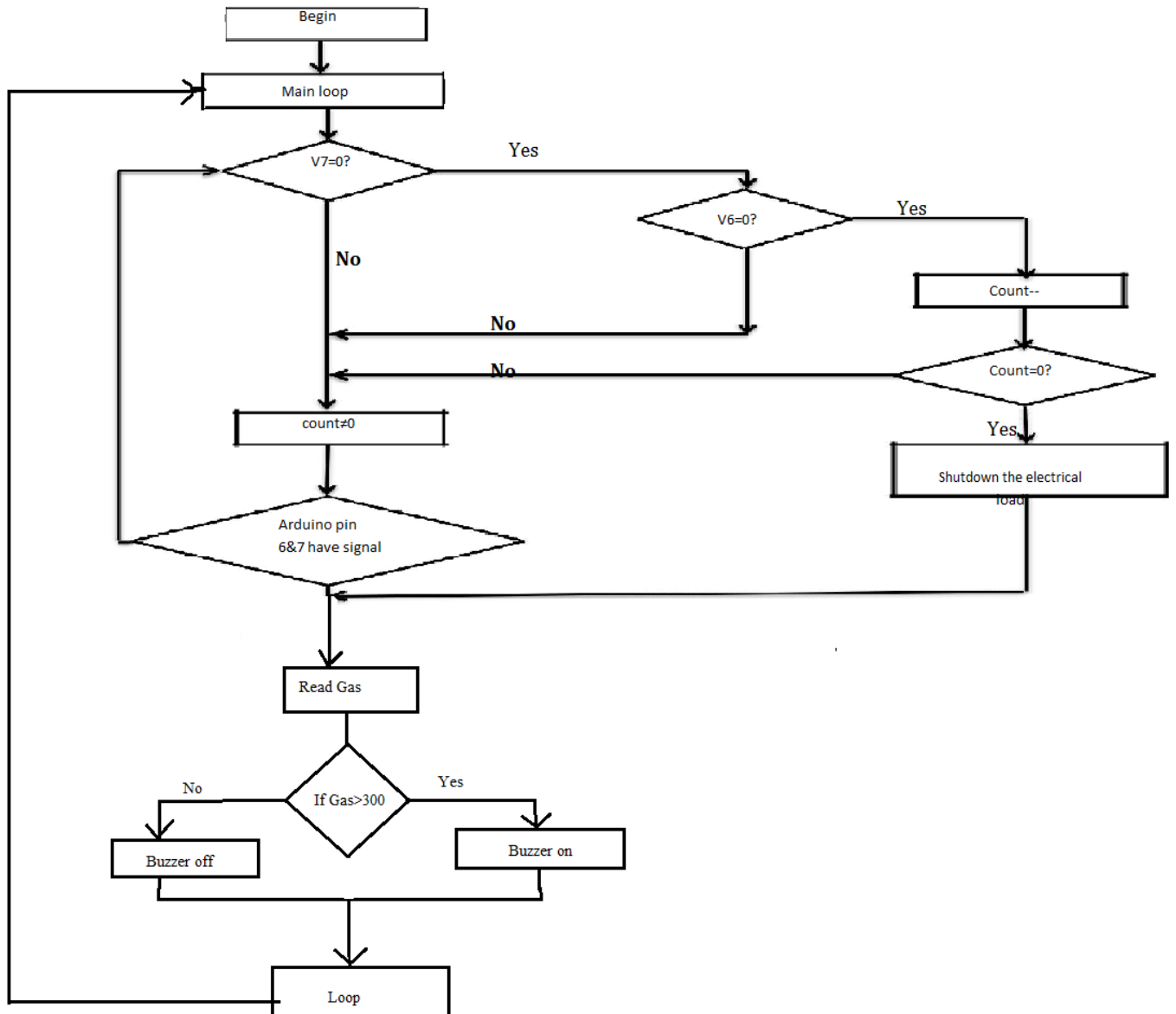

Chapter Five

System Implementation and Testing

5.1 TESTING

Testing is a vital process in the development and realization of any design, be it hardware based, software based or both. The various components and their circuitry have to be tested to ensure that all the components on board are certified okay and in good working condition. The components that did not give the required output specification were isolated and troubleshoot to determine the nature and cause of the component failure through careful analysis, that is examination of the working principles of the component(s).

5.2 Display testing

When a program to show 'hello, world !' is burnt into the arduino, the display shows the sentence. The following figure shows the display test.

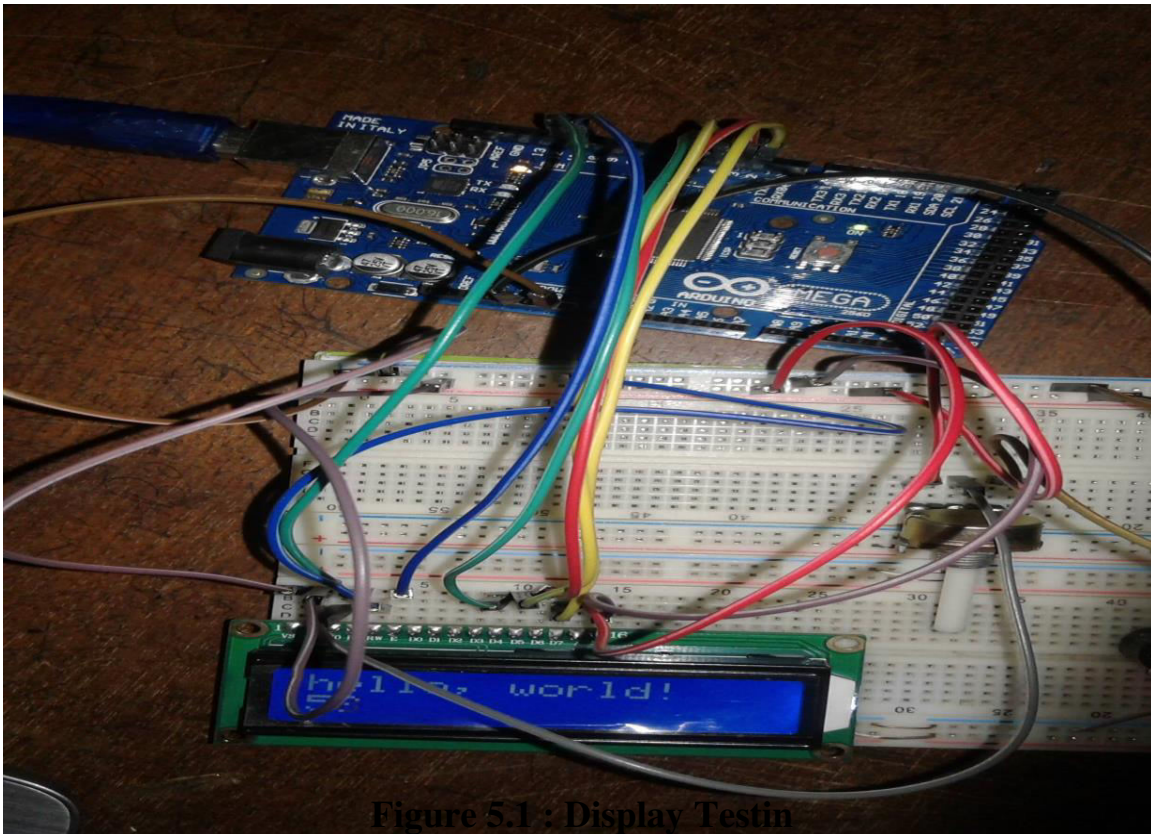

Figure 5.1 : Display Testin

5.3 Sensor

Testing

This section we test the sensor implementation by using a Photodiode and LED.

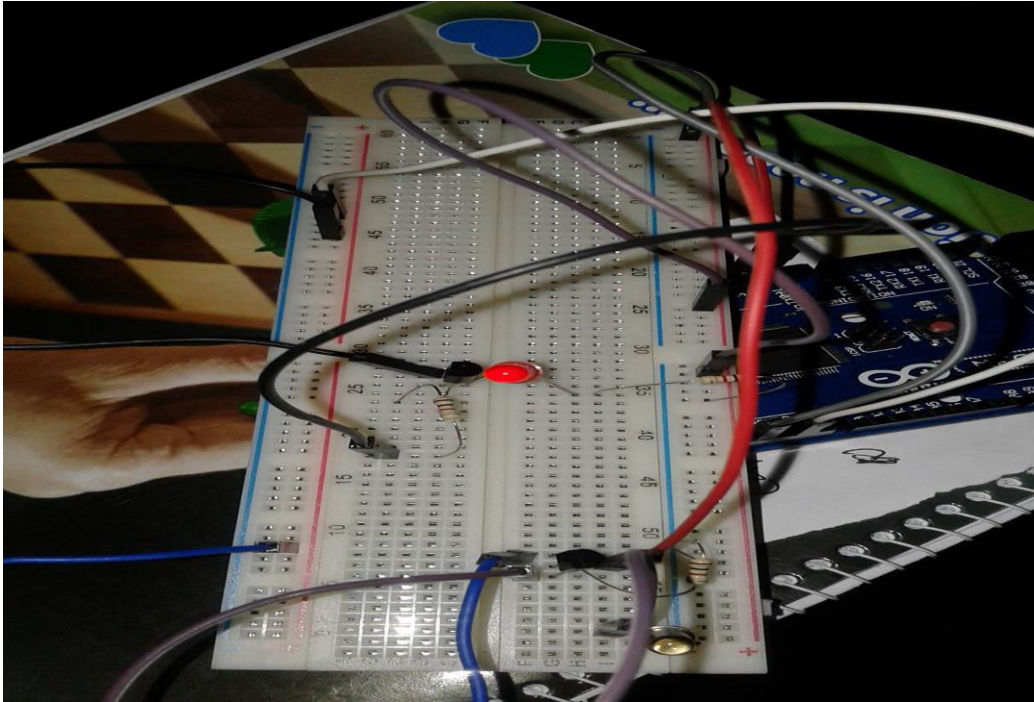

Figure 5.2 :Sensor Testing

5.4 Smoke Sensor Testing

This section we detect smoke by using smoke sensor.

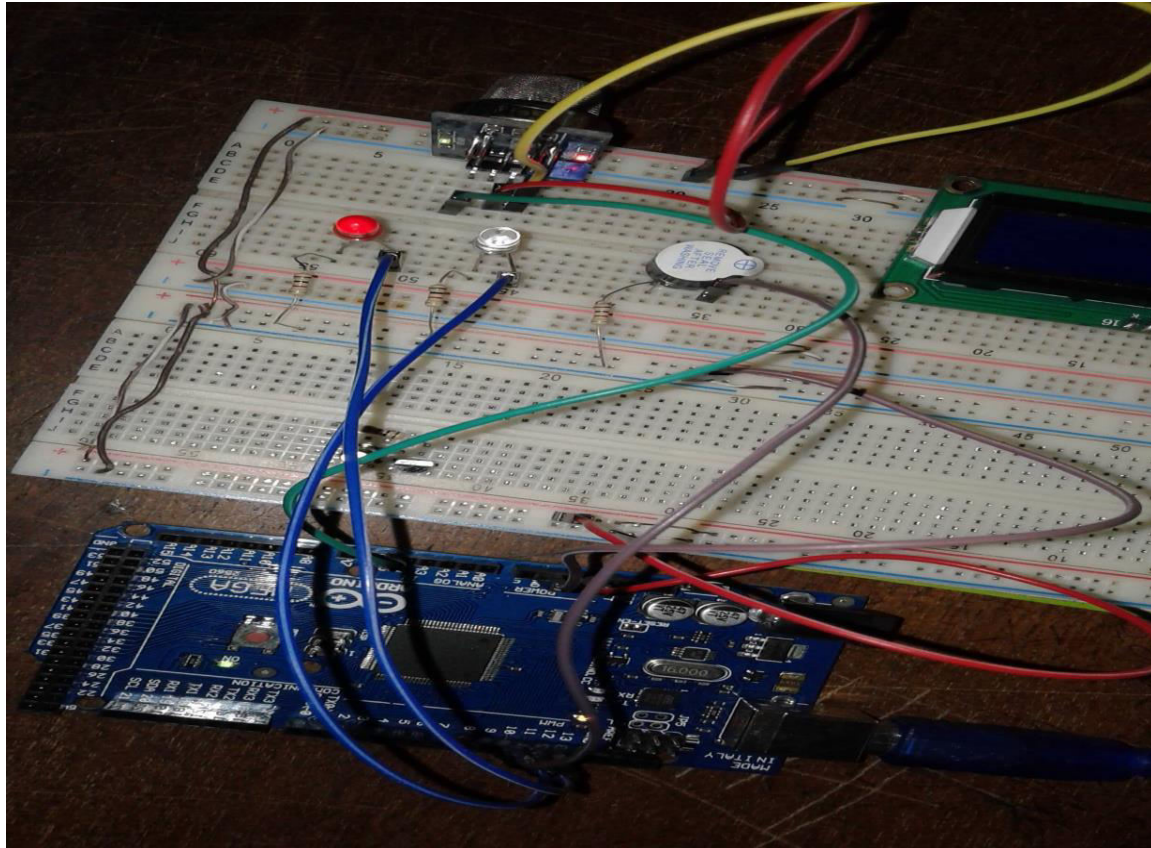

Figure 5.3 : Smoke Sensor Testing

5.5 Development of the whole System

After completing the whole circuit and developing the control system and setting in the door ,it has been observed that it works properly. Therefore it can be said that it is ready for commercialization. The complete system is shown in the following figure.

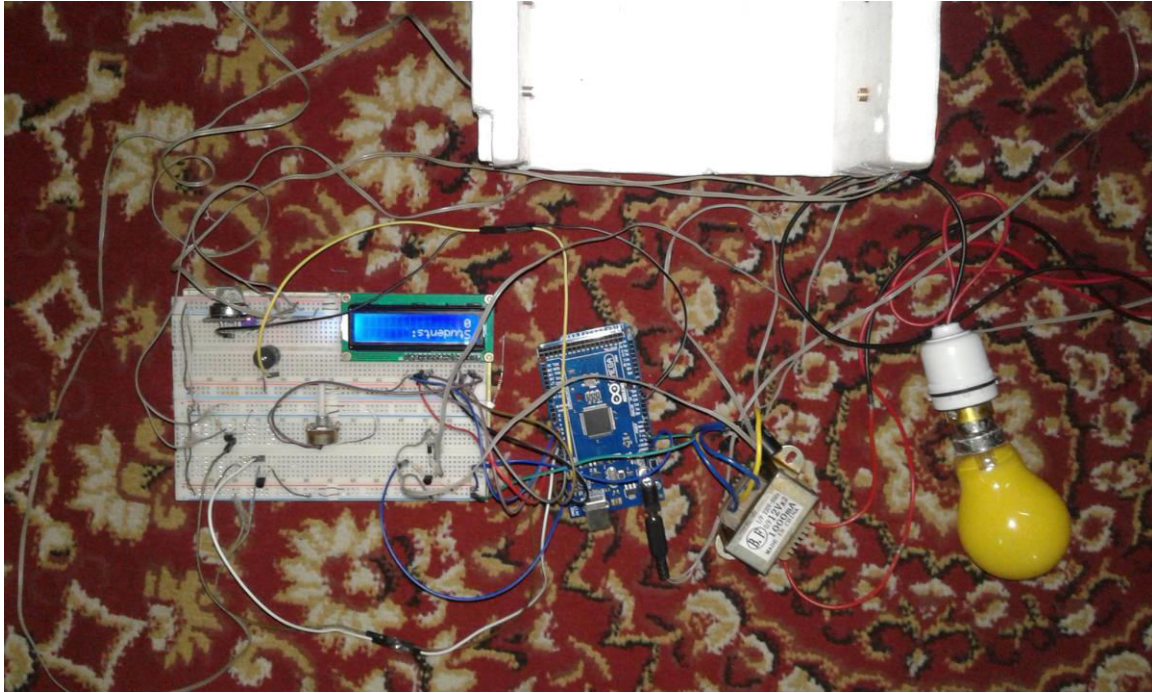

Figure 5.4: When No Student Enter.

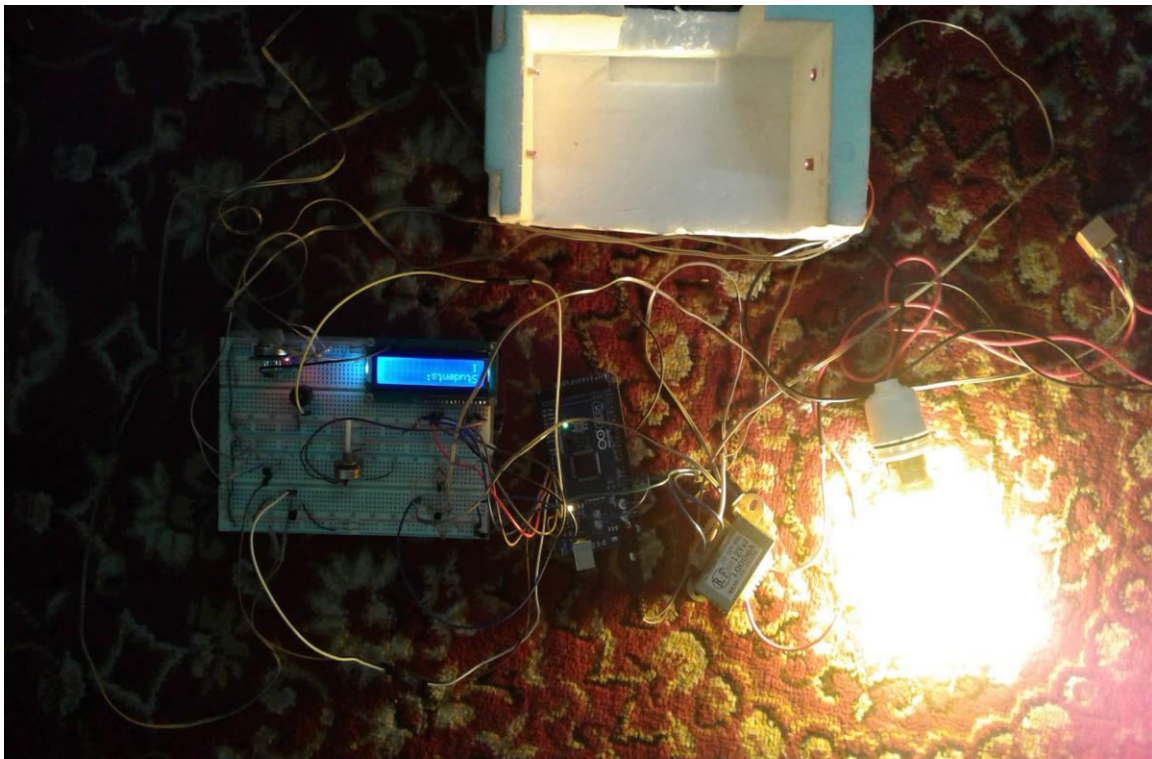

Figure 5.5: When Student Enter.

5.5 EXPECTED TEST RESULTS

The design of the microcontroller based automatic room light controller with bidirectional counter and smoke detector is meant to be a system that is used to take the number of people in a particular room on entrance and exist, so that when there is no one in the room the lights, fans and gadgets are turned off automatically. With this system the user do not need to press any button, once he/she enters the room, the room the light turns on. And smoke sensor detect smoke automatically. To effectively carry out an intensive test, it is a good practice to run or retest the project as many times as possible to make sure that the desired design specification is met. The result that is expected is for the system, when the laser rays is blocked, the sensor sends signals which will activate the load and power the lights. The expected test results were obtained as the photo transmitter (entrance) communicated successfully with the receiver on the receiver (exit) section of the control system. The signal received was then able to activate the load and control the lighting point successfully.

CHAPTER SIX

SUMMARY AND CONCLUSION

6.1 Conclusion

The smart home appliance control system was designed and developed for minimizing the wastage of electricity. We use 5V from Arduino board and use 12V DC power supply for relay connection. We use the photodiode for receiving laser light because it is low cost, low noise,

excellent linearity in output photocurrent over 7 to 9 decades of light intensity and fast response times.

Finally, we design and develop a Arduino base smart home appliance control system. We fix the entire problem that we have. Finally, we successfully achieve our primary goals.

In this study, the application of microcontroller with improved algorithm of extended specifications has reduced the misuse of electricity and improves the security system. We see that our smart home appliance control system is efficient and the production cost is low. So, our smart home appliance control system is suitable for commercial.

6.2 Future Work Scope

This project gives us an opportunity to do a big project in future. The applications stated above are some demo applications that are absolutely possible with its future development. Initially for the limitation of time and required fund we were able to develop just a home appliance control system. The system will also work using IR sensor. It will be more efficient than Laser light and Photodiode. So, we have a big work scope in this sector. We hope that, we will be able to complete all the features needed for its ultimate applications.

APPENDIX

Programming code of Gas Detection for

Testing

We write the code for gas detection in the Arduino software:

```
/******
```

All the resources for this project:
<https://www.hackster.io/Aritro>

```
*****/
```

```

int buzzer = 10;
int smokeA0 = A5;
// Your threshold value
int sensorThres = 400;

void setup()

{

  pinMode(buzzer, OUTPUT);
  pinMode(smokeA0, INPUT);
  Serial.begin(9600);
}

void loop()

{
int analogSensor = analogRead(gasA0);

Serial.print("Pin A0: ");
Serial. Println(analogSensor);
// Checks if it has reached the threshold value
if (analogSensor > sensorThres)
{

  tone(buzzer, 1000, 200);
}
else
{

  noTone(buzzer);
}
delay(100);
}

```

Programming code of count for Testing

We write the code for count in the Arduino software. While light will be ON or OFF thus kind of matter is written in this code. The count code is:

```

// constants won't change. Used here to
// set pin numbers:

const int ledPin = 13;

```

```

// the number of the LED pin
// Variables will change:
int ledState = LOW;
// ledState used to set the LED
long previousMillis = 0;
// will store last time LED was updated

int i,j,v6,v7;
int En=1,Ex=1,Enp=1,Exp=1;
int count=0;

// will quickly become a bigger number than can be stored in an int.
long interval = 1000;
// interval at which to blink (milliseconds)

void setup()
{

// set the digital pin as output:

pinMode(ledPin, OUTPUT);
pinMode(6,INPUT);
pinMode(7,INPUT);
}
void loop()
{
v6 = digitalRead(6);
if (v6==0)
{if (Exp!=0)
Enp=0; En=0;}
if((v6==1)
& (En==0)
& (Ex ==0)
& (Exp==0))
{
count--;
Ex=En=Exp=

}
v7=digitalRead(7);
if(v7==0)
{if(Enp!=0)
Exp=0;Ex=0;}
if((v7==1)
& (En==0)
& (Ex==0)

```

```

& (Enp==0))
{
count++;
Ex=En=Enp=1;
}
if(count>0)
digitalWrite(12,HIGH);
else
digitalWrite(12,LOW);
delay(50);
}

```

Combination of All Programming code

We connected the LCD display with Arduino and write a program for operates that display. The LCD code is:

```

#include<LiquidCrystal.h>
const int ledPin = 13;
const int buzzer =10;
const int smokeA0 = A5;
const int Thres = 300;
        // the number of the LED pin
LiquidCrystal lcd(12,11,5,4,3,2);
int backlight=8;
        // pin 8 will control the backlight
        // Variables will change:
int ledState = LOW;
        // ledState used to set the LED
long previousMillis = 0;
        // will store last time LED was updated
int i,j,v6,v7;
int En=1,Ex=1,Enp=1,Exp=1;
int count=0;
        // will quickly become a bigger number than can be stored in an int.
long interval = 1000;
        // interval at which to blink (milliseconds)

void setup()
{
    // set the digital pin as output:
    pinMode(buzzer, OUTPUT);
    pinMode(smokeA0, INPUT);
    pinMode(ledPin, OUTPUT);
    pinMode(6,INPUT);
    pinMode(7,INPUT);
}

```

```

    lcd.begin(16,2);
    pinMode(backlight,OUTPUT);
}

void loop()
{
    // gas detection begins here
    int gas = analogRead(smokeA0);
    if(gas > Thres)
    tone(buzzer, 1000, 200);
    else noTone(buzzer);
    //Door count begins here
    v6 = !digitalRead(6);
    if (v6==0)
    {if (Exp!=0) Enp=0; En=0;}
    if((v6==1)& (En==0)&(Ex ==0)& (Exp==0))
    {
        count--;
        Ex=En=Exp=1;
    }
    v7=!digitalRead(7);
    if(v7==0)
    {if(Enp!=0)Exp=0;Ex=0;}
    if((v7==1)& (En==0)& (Ex==0)& (Enp==0))
    {
        count++;
        Ex=En=Enp=1;
    }
    if(count>0)
    digitalWrite(13,HIGH);
    else
    digitalWrite(13,LOW);
    digitalWrite(backlight,HIGH);
    // turn backlight on. Replace 'HIGH' with 'LOW' to turn it off.
    lcd.clear();
    // start with a blank screen
    lcd.setCursor(0,0);
    // set cursor to column 0, row 0 (the first row)
    lcd.print("Person:");
    lcd.setCursor(0,1);
    // set cursor to column 0, row 1
    lcd.print(count);

    delay(50);
}

```

References:

- [1] Prof, Asha Rawat “Automated Room Light Controller with Visitor Counter”, Imperial Journal of Inter Disciplinary Research, Vol. 2, Issue 4, 2016
- [2] Subhankar Chattoraj, Aditya Chakraborty,” Bidirectional Visitor Counter with Automatic Room Light Controller and Arduino as the master controller ”, International Journal of Scientific and Research Publications, Vol. 6, Issue 7, July 2016.
- [3] Sonali K. Pawar “AUTOMATIC ROOM LIGHT CONTROLLER USING MICROCONTROLLER AND VISITOR COUNTER ”, IJICTRD – INTERNATIONAL JOURNAL OF ICT RESEARCH AND DEVELOPMENT VOL-1 ISSUE-4, 6, August, 2016.
- [4] Asst prof, E.Shilpa “ Implementation of Automatic Room Light Controller with Visitor Counter Design using 8051 Microcontroller”, International Journal of Innovative Research in Computer and Communication Engineering Vol. 5, Issue 2, February 2017.
- [5] D.Hari Priya “Gas Leakage System”
International Journal of Scientific and Research Publications, Vol 4, Issue 9, September 2014.
- [6] Kausik sen “Automated Fire Detection and Controlling System.”,
International Advanced Research Journal in Science, Engineering and Technology Vol. 2, Issue 5, May 2015.
- [7] Winfred Adjardjah “Design and Construction of a Bidirectional Digital Visitor Counter”,
Computer Engineering and Intelligent System. Vol.7, No.2, 2016
- [8] Gaurav Waradkaret “Automated Room Light Controller with Visitor Counter”,
Imperial Journal of Interdisciplinary Research (IJIR) Vol-2, Issue 4, 2016
- [9] Kimbley et “AUTOMATIC ROOM LIGHT CONTROLLER USING MICROCONTROLLER AND VISITOR COUNTER ”, IJRET: International Journal of Research in Engineering and Technology Vol.05 Issue, 03 Mar-2016,
- [10] sibu skaraet “Automatic Lighting Controller Sibu Skaria”,
International Journal of Engineering Research and Development Vol.10, Issue 2, 2014.