



# East West University Bangladesh

***Industrial Training***

***Report On***

***Network Planning & Optimization***

***Of Metro Telworks Ltd***

*An internship report submitted to East West University as a partial  
Fulfillment for the Bachelor of Science Degree in Electronics and  
Telecommunication Engineering.*

**Submitted By:**

Mohammad Nahidur Rahman

ID: 2008-2-56-036

**Supervised By:**

Dr. Mohamed Ruhul Amin

Professor

Department of Electronics and Communication Engineering.

## **Letter of Transmittal**

15<sup>th</sup> May, 2014

Dr. Mohamed Ruhul Amin

Professor

Department of Electronics and Communication Engineering

East West University

Subject: Submission of Project Report as Industrial Training (ETE- 498).

Dear Sir,

I am pleased to let you know that I have completed my internship program Metro Telworks Dhaka. The attached contains the internship report that has prepared for your evaluation and consideration. The internship has given me a great opportunity to work with the update networking technology closely and also gave me opportunities to apply the theoretical knowledge in real life situation which I have acquired since last four years from you and other faculty members of EWU, which would be a great help for me in future.

I am very grateful to you for your guidance throughout the internship period, which helped me a lot to acquire practical knowledge.

Thanking You

Yours Sincerely,

Md. Nahidur Rahman

**Mohammad Nahidur Rahman**

**ID: 2008- 2- 56- 036**

**Department of ECE**

**East West University**

## **Declaration**

This is certified that I have completed my internship as well as prepared my report in partial fulfillment of the requirement for the degree of B.Sc. in Electronics and Communication Engineering, under the course Industrial Training (ETE 498). It has not been submitted elsewhere for the requirement of any degree or for any other purpose except for publication.

*Md. Nahidur Rahman*

---

**Mohammad Nahidur Rahman**

**ID: 2008-2-56-036**

**Department of ECE**

## **Acceptance**

This Industrial Training report presented to the department of Electronics and Communication Engineering, East West University is submitted in partial fulfillment of the requirement for degree of B.Sc. in Electronics and Telecommunication Engineering, under complete supervision of the undersigned.



**Dr. Mohamed Ruhul Amin**

Professor

Department of ECE

East West University

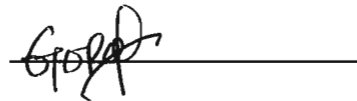

**Gopal Chandra Gope**

Radio Network Optimization Eng.

Metro Telworks Ltd

Bangladesh

## **Acknowledgement**

First I would like to express my gratitude to almighty ALLAH for giving me the strength to perform my responsibility as an intern and complete the report within due time.

My special thanks go to supervisor **Dr. Mohamed Ruhul Amin Professor**, Electronics and Communications Engineering Department, East West University, Dhaka, who was my academic supervisor for the course ETE 498 (Industrial Training). He allocated valuable time throughout the Internship period to guide me for successfully completion of the internship and preparing this report.

I would specially like to convey my gratitude to my company supervisor **Gopal Chandra Gope**, Radio Network Optimization Engineer, Metro Telworks Ltd. who gave me the opportunity of the internship under his department and guiding me with lots of effort and time.

Last but not the least, I would like to convey my gratitude to my colleagues, friends and teachers who gave me good advice, suggestions, inspiration and support.

## **Executive Summary**

It was a great opportunity to work under **Metro Telworks Ltd**. The main purpose of the program was to perceive the real life situation. The academic knowledge is not well enough to compete with real world. This internship program was helpful to face the real working environment.

This internship report contains all the information about my work experience with Metro, which started its work in Bangladesh from 2006. In Metro I have spent a good time in learning and was rewarded for my best efforts, learnt to deal with different situations, had experience of corporate working environment which affects an employee performance and attitude towards work, had good time in learning and performing. I have also gathered experience about the turbulence of the trouble times while touchstone was going through one of its major transition phase. Confidence, on time decision making, consistency, hard work, team work, seeking success out of dark, innovation, creativity, organizational survival are the key learning's out of my job and I would like to say that it will be one of my best skill that would remain with me and help me in future which will offer many challenges. I would like to highlight this, that my experience with METRO TELWORKS LTD. was very memorable and full of learning's, where I found a lot of positive changes in my attitude, learning and behavior.

## Benefits of Internship

The objective of most horticulture internships is to enable students to integrate their previous educational schooling with more professional knowledge and skills gained through practical, “real world” work experience with industry employers. In essence, it is a carefully monitored work experience in which a student has intentional learning goals and objectives that reflect on both the student’s and the employer’s needs. So, internships are quite beneficial for both the internee and the organization as an organization can have internees hired for a lesser convenient remuneration. Some additional benefits are-

- Internship helps an internee to gain work experience and transferable skills for the first time.
- Internship makes able an internee to experience a prospective career path.
- Internship gives a student the opportunity to gain practical experience, by applying methods and theories learned in classes.
- Through internship an intern can easily make network with professionals in work field, for references and future job opportunities.
- Internship Bridge the gap between theoretical study and the professional world.
- Helps a student to gain self-confidence and motivation and develop expertise in interacting with people.
- An intern can have personal growth experiences and exposure to different job opportunities.
- Internship gives student hands-on opportunities to work with equipment and technology.

## **Corporate Information**



Metro Teleworks was founded in 2004 by experienced telecom professionals. Established itself as a leading service provider in India and has expanded successfully to other fast growing markets in Asia and Africa

Key Services (GSM/GPRS/EDGE, 3G, CDMA 1X, WCDMA, Wi-MAX, LTE)

### **RF Planning and Implementation:**

- Initial dimensioning of the radio network
- CW Propagation model tuning
- Site survey and candidate identification
- Coverage and capacity planning
- Frequency and neighbor planning
- Interference analysis
- Parameter planning
- Field measurement and acceptance testing
- BTS Installation and commissioning
- Final foot prints and pre-launch optimization



**RF Optimization:**

- Parameter configuration check and optimization
- Site hardware configuration and optimization
- Frequency & Strategy planning
- Top X Site targeting (Drop call, high traffic, handover)
- Drive test and verification
- Various optimization reports (Drop call, handover)
- System growth / expansion Planning
- Ongoing active Operations and Maintenance

**Network Audit:**

- Coverage drive test Outdoor and Indoor
- Speech Quality Index (SQI)
- Voice Quality – Customer Perceived
- Congestion- Network availability
- Receive Level Fluctuation
- Recommendations for network improvement

**Network Performance:**

- Provide Subscriber perception of Quality service
- QoS reports for Senior Management
- Drive test & Performance data control
- Benchmark figures against competitors
- Independent benchmarking of vendor equipment
- Continuous/repetitive monitoring to highlight slow degradation of network quality
- Provision of engineering data for further analysis

## Contents

---

Acknowledgement	i
Executive Summary	ii
Benefits of Internship	iii
Corporate Information	iv
Contents	1
<b>Chapter 1</b>	
Introduction	3
<b>Chapter 2</b>	
Introduction to computer networks	5
2.1 Network	6
2.2 Networking	6
<b>Chapter 3</b>	
GSM Over view	7
3.1 System Architecture	8
3.2 Network and switching subsystem (NSS)	10
3.3 Operation Subsystem (OSS)	11
3.4 GSM Network Areas	12
<b>Chapter 4</b>	
Program Management	14
4.1 Network Design and Optimization	15
4.2 Network Deployment	16
4.3 Network Auditing and Consultancy	16
4.4 Network Benchmarking	17
4.5 List Of Customers	17
4.6 Projects Tools	18

4.7 Technologies	19
------------------	----

## **Chapter 5**

Drive Test	20
5.1 The Purpose of Drive Testing	21
5.2 When do drive test	22
5.3 Where do drive test	22
5.4 Types of drive test	22
5.5 Tools (Drive Test Kit)	23
5.6 Software and necessary files	27

## **Chapter 6**

Functionality Test	31
6.1 Procedure of Functionality Test	32

## **Chapter 7**

Conclusion	36
Reference	38

# **Chapter 1**

## **Introduction**

## Introduction

In telecommunication, a communications system or networking system is a collection of individual communications networks, transmission systems, relay stations, tributary stations, and data terminal equipment (DTE) usually capable of interconnection and interoperation to form an integrated whole. The components of a communications system serve a common purpose, are technically compatible, use common procedures, respond to controls, and operate in union.

The Wireless telecommunications industry has undergone explosive growth and has become global in its scope and ambitions. Spectrum is becoming severely congested. Quality network design is no longer a “nicety”, but rather a necessity. With the New technologies like LTE, 3G, Wi-Max being introduced, competition is getting severe and the Telecommunications Industry is looking for simpler, cost effective and innovative ways to maintain the Networks.

Metro Telworks was formed in 2004 and is primarily engaged in providing RF services & in building solutions to OEM’s, NEM’s and Telecom Operators. With established foot prints across the Globe, Metro Telworks has already started implementing Automation in its services resulting into Cost Efficient and improved delivery to its Customers. Metro Telworks has expanded itself to cover Turnkey solutions, RF Planning and Optimization, Network Performance Services, Switch Planning, IP Planning, Project management and End to End Services as a Solution, in its ambit of Services. It also undertakes task based projects requiring delivery of tangible results in the form of either cell site production or network quality improvement and has consistently met or exceeded Key Performance Indicators (KPI).

### The Goal of Metro Telworks

“To provide Cost efficient Services for emerging Telecom Networks, carrying innovative products to enable our customers to achieve excellence in their performance”

The Wireless industry still needs creative problem solvers, grounded in experience but aspiring to develop new solutions, well versed in all of the essential details of infrastructure equipment from manufactures the world over. We have ability to build team in minimum lead-time. Our presence in 14 countries enables us to access quicker and skilled resources. Our philosophy goes beyond meeting client requirements. We meet your needs by putting ourselves in your shoes and thinking of unforeseen situations that you may come across.

## **Chapter 02**

### **Introduction to computer networks**

## **2.1 Network**

A network is a combination of hardware and software that sends data from one location to another. The hardware consists of the physical equipment that carries signals from one point of the network to another. The software consists of instruction sets that make possible the services that we expect from a network. A computer network or data network is a telecommunications network that allows computers to exchange data. The physical connection between networked computing devices is established using either cable media or wireless media. The best-known computer network is the Internet.

Network devices that originate, route and terminate the data are called network nodes. Nodes can include hosts such as servers and personal computers, as well as networking hardware. Two devices are said to be networked when a process in one device is able to exchange information with a process in another device.

Computer networks support applications such as access to the World Wide Web, shared use of application and storage servers, printers, and fax machines, and use of email and instant messaging applications. The remainder of this article discusses local area network technologies and classifies them according to the following characteristics: the physical media used to transmit signals, the communications protocols used to organize network traffic, along with the network's size, its topology and its organizational intent.

## **2.2 Networking**

We can compare the task of networking to the task of solving a mathematics problem with a computer. The fundamental job of solving the problem with a computer is done by computer hardware. However, this is a very tedious task if only hardware is involved. We would need switches for every memory location to store and manipulate data. The task is much easier if software is available. At the highest level, a program can direct the problem-solving process the details of how this is done by the actual hardware can be left to the layers of software that are called by the higher levels.

Compare this to a service provided by a computer network. For example, the task of sending an e-mail from one point in the world to another can be broken into several tasks, each performed by a separate software package. Each software package uses the services of another software package. At the lowest layer, a signal, or a set of signals, is sent from the source computer to the destination computer.

**Chapter 03**  
**GSM over View**



### 3.1 System Architecture:

A GSM Public Land Mobile Network (PLMN) consists of at least one Service Area controlled by a Mobile Switching Center (MSC) connected to the Public Switched Telephone Network (PSTN), see Figure gsm1.

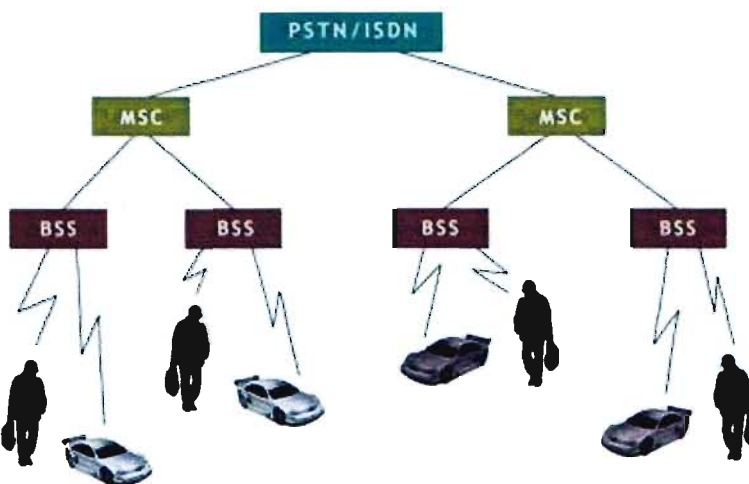

Fig1. The architecture of a GSM Public Land Mobile Network (PLMN)

A Base Station Subsystem (BSS) consists of a Base Station Controller (BSC) at least one radio access point or Base Transceiver Station (BTS) for Mobile Stations (MS), which are mobile phones or other handheld devices (for example PDA computers) with phone interface. A BTS, with its aerial and associated radio frequency components, is the actual transmission and reception component. A Network Cell is the area of radio coverage by one BTS. One or more BTSs are in turn managed by a BSC. A network cell cluster covered by one or several BSSs can be managed as a Location Area (LA). All these BSSs must however be controlled by a single MSC. In Figure gsm2 is shown three LAs of 3, 4 and 4 cells respectively with a MS moving across cell and LA boundaries.



Fig2. A MS moving across cell and LA boundaries. 3 LAs consisting of 4 and 5 cells respectively are shown.

A more detailed architecture of a single MSC controlled Service Area is outlined in Fig3.

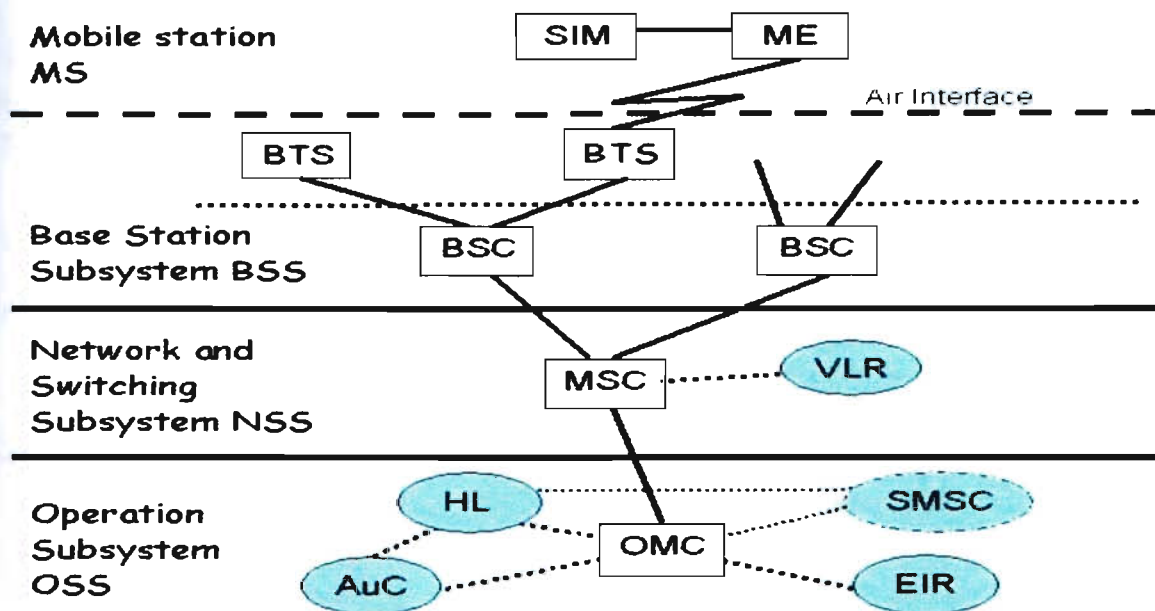

Fig3. The GSM network architecture for a single MSC controlled Service Area

The components of the tree GSM network subsystems

- Radio Subsystem (RSS) consisting of the BSSs and all BSS connected MS devices.
- Network and Switching Subsystem (NSS)
- Operation Subsystem (OSS)

Specified in GSM 01.02 ('General description of a GSM Public Land Mobile Network(PLMN)') and the GSM components

- ME = Mobile Equipment
- BTS = Base Receiving Station
- BSC = Base Station Controller
- MSC = Mobile Switching Center
- VLR = Visitor Location Register
- OMC = Operation and Maintenance Center
- AuC = Authentication Center
- HLR = Home Location Register
- EIR = Equipment Identity Register
- SMSC = Short Message Service Centre

A MSC is also through a Gateway MSC (GMSC) connected to other MSCs and to the Public Switched Telephone Network (PSTN) with the Integrated Services Digital Network (ISDN) option. The Inter-Working Function (IWF) of GMSC connects the circuit switched data paths of a GSM network with the PSTN/ISDN. A GMSC is usually integrated in an MSC, see Figure gsm4.

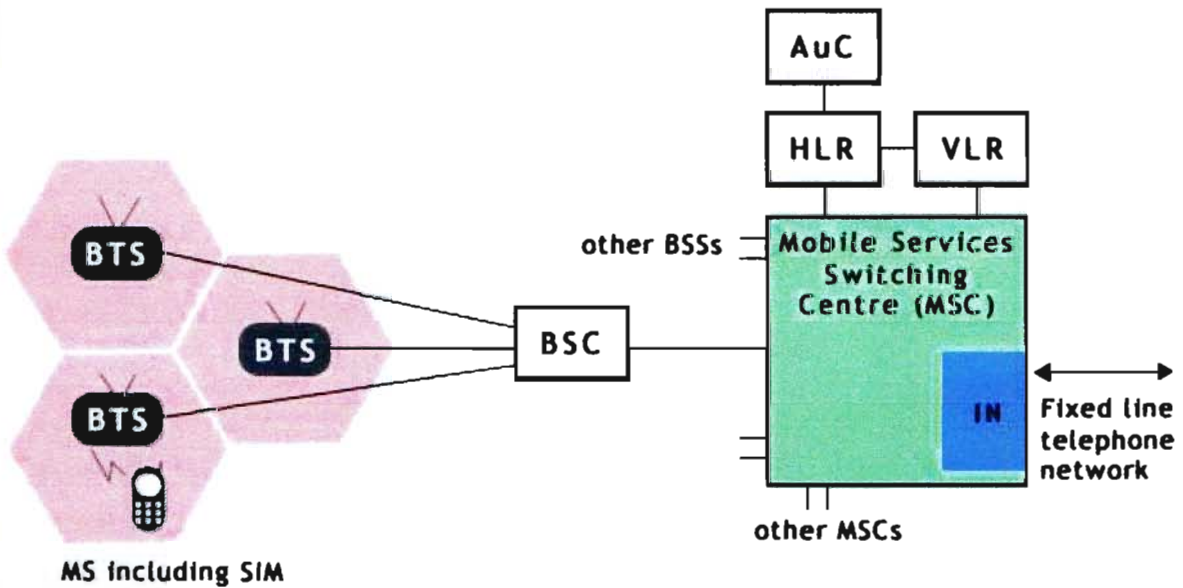

- |   |  |
|---|--|
| <i>Mobile Station = MS</i>              | <i>HLR = Home Location Register</i>    |
| <i>Subscriber Identity Module = SIM</i> | <i>VLR = Visited Location Register</i> |
| <i>Base Transceiver Station = BTS</i>   | <i>AuC = Authentication Centre</i>     |
| <i>Base Station Controller = BSC</i>    | <i>IN = Interrogating Node</i>         |

Fig4. Basic GSM network components

### 3.2 NETWORK AND SWITCHING SUBSYSTEM (NSS)

NSS consists of the Mobile Switching Center (MSC) and the Visitor Location Register (VLR). A MSC manages multiple BSSs and is responsible for setting up, managing and shutting down connections, handling call charges supervising supplementary services, such as call forwarding, call blocking and conference calling.

VLR contains information about all MSs currently within range of the associated MSC. This information is needed for routing a call to a particular MS (mobile telephone) via the proper BSS and radio cell. The VLR also maintains a list of MSs belonging to subscribers of other GSM networks. Such subscribers have

logged or roamed into the network of the associated MSC. The area covered by a MSC is actually called a MSC/VLR Service Area, which can consist of several LAs as is shown in Figure gsm5.

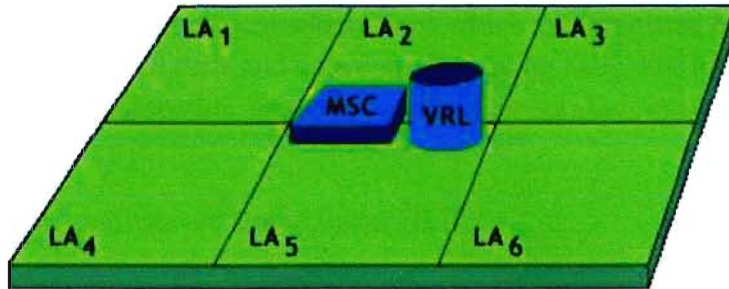

Fig5: A MSC/VLR Service Area

### 3.3 OPERATION SUBSYSTEM (OSS)

The OSS consists of

1. The Operation and Maintenance Center (OMC)
2. The Authentication Center (AuC),
3. The Home Location Register (HLR)
4. The Equipment Identity Register (EIR).
5. OMC is responsible for
6. Regular network operation
7. Subscriber administration
8. Call billing.

AuC is the security component on the network side. AuC generates and manages all cryptographic keys and algorithms needed for network operation, especially for authentication of the MSs (i.e., the SIMs). HLR contains all of the subscriber data as well as the localization data for each of the MS. EIR contains essential data, such as the serial numbers of all MSs represented in the network. OSS also controls the Short Message Service Centre (SMSC) for transmission of SMS messages. SMSC need information in HLR for the routing of SMS messages.

### 3.4 GSM NETWORK AREAS

In GSM, there is a strong distinction between subscribers, which are identified by their SIM, and the hardware they use for making phone calls and data communication calls. For identification both entities before and during GSM service allocation, several identification numbers exist and are stored in HLR, VLR and EIR.

The following identification numbers are stored in the HLR:

**International Mobile Subscriber Identity (IMSI)**, a permanent ID assigned to each GSM network subscriber.

**International Mobile Subscriber ISDN Number (MSISDN)**, the ISDN number (phone number) permanently assigned to each GSM subscriber.

**Mobile Station Roaming Number (MSRN)**, a temporary ISDN number of a subscriber. This number is assigned by the local VLR each time, the subscriber enters its MSC/VLR area. The MSRN is then sent to the HLR and to the GMSC.

The address of current VLR and MSC (if available), an address of the area the subscriber is currently in.

**Local Mobile Subscriber Identity (if available)**, a short ID temporarily assigned to an active subscriber by a VLR and sent to the HLR.

The following identification numbers are stored temporarily at the VLR associated with the MSC which is currently controlling an active MS:

IMSI

MSISDN

MSRN

**Location Area Identity (LAI)**, the ID of the Location Area (LA), in which subscriber is or has been connected to a GSM network.

**Temporary Mobile Subscriber Identity (TMSI)**, temporarily assigned to an active MS in order to prevent the IMSI from being transmitted too often over the radio interface. The TMSI is periodically changed during a call.

**Equipment Identity Register (EIR)** is a database for mobile equipment information of all subscribers. In this database, three lists (white, black and gray) store identification

numbers, which are unique to all mobile terminals. The white list contains allowed terminals, the black list contains un allowed terminals (e.g. stolen or lost), and the gray contains terminals with known bugs.

The area covered by one GSM operator is called the PLMN Service Area, which can consist of several MSC/VLR Service Areas as I shown in Fig6. A typical PLMN Service Area is thus the area of a country, a state, or a region. A GSM Network Area is thus a hierarchy with the levels

PLMN Service Area

MSC/VLR Service Area, see Fig5

Location Area (LA), see Fig2

Network Cell.

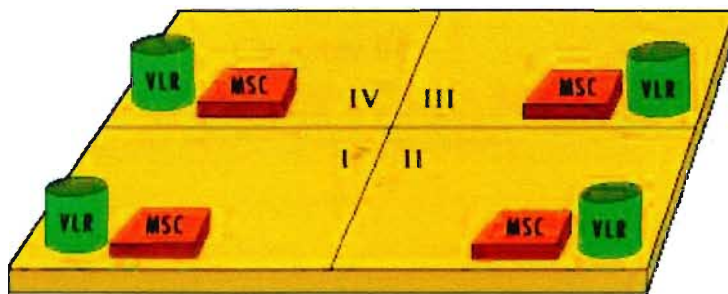
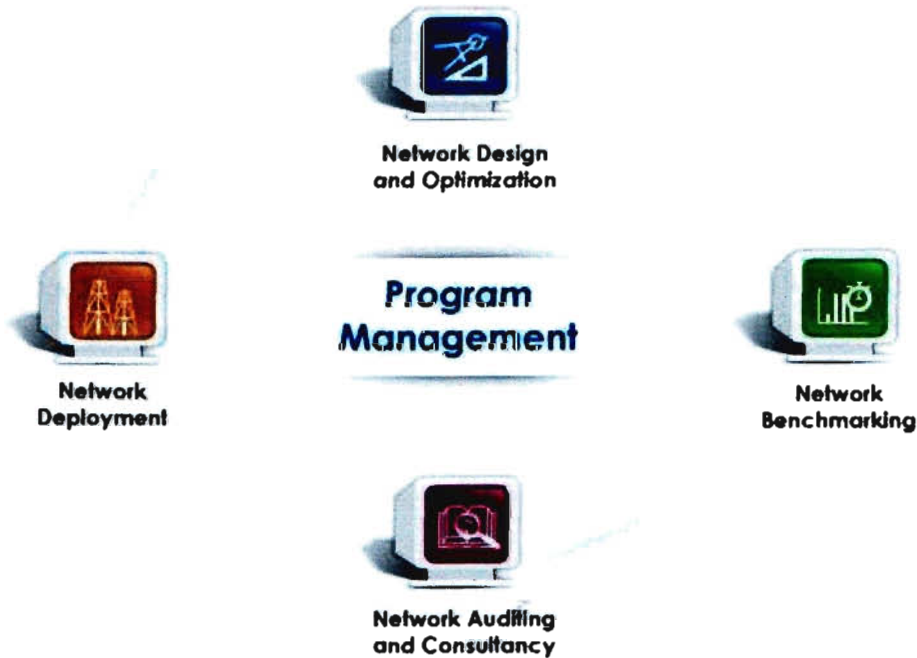

Fig6. A PLMN Service Area for a GSM operator

**Chapter 04**  
**Program Management**



#### 4.1. Network Design and Optimization

In this service, METRO TELWORKS LTD. will provision and allocate engineering resources within your company's network design and optimization organization. With strong experience in Network Design and Optimization, our expertise will not only help speed up your network deployment but also, will provide on-job training and know-how knowledge transfer to the local engineers.

##### Network Design

- Technical Site Survey to determine antenna design for optimum coverage
- Site Configuration Study
- Coverage and Interference Prediction and Frequency Planning
- Neighboring and Parameter Planning



## **Network Optimization**

- BSS Parameter Sanity Check
- Field Measurement and Site Audit
- Coverage verification, Capacity Analysis, Frequency and Neighboring Fine-Tuning
- Control Channel Optimization

## **4.2. Network Deployment**

This is a turnkey solution. METRO TELWORKS LTD. will take full responsibility in network design, optimization, acceptance and project management. With our strong technical expertise and different operation in different countries, we are able to leverage different expertise and ramp up or down project engineering resources easily to meet project requirement. You can be sure to have a good quality network launch.

### **Network Deployment**

Our Services will cover the full range of tasks from the Nominal Planning until Sites are activated ON-AIR

- Network Nominal Planning, Coverage Prediction and Dimensioning
- Technical Site Survey
- Frequency and Parameter Plan Preparation
- Site On-Air verification for installation defect
- Network Benchmarking and Acceptance

## **4.3 Network Auditing and Consultancy**

A mature network with the aggressive growing traffics requires network detailed analysis, good expansion and long term strategy planning. In this service, we provide top consultants with at least 15 year experience in the technologies. Our consultants will audit the network from different aspects from technical to market analysis till long term network expansion strategy.

- Network Audit and Short Term Improvement Plan
- Market Analysis, Traffic Modeling and Long Term Network Expansion Plan
- Support Equipment Vendors, RFQ Evaluation and Recommendation
- Technical Reports, White Papers Write-Up

#### 4.4 Network Benchmarking

Network Benchmarking is an exercise to simulate the mobile users' perception or to understand the network performance against other networks' competitors. Different equipment vendors have different statistical formulas and measurement sensitivities. It is no other fair quality indicators except using network benchmark data to compare the network qualities. This exercise will deliver a report to pin-point the network strength, weaknesses and recommend the possible solution to resolve the network quality issues.

- Perform System Drive-test to measure mobile users' perception
- Network Comparison Measurement to measure own network and different competitors' networks.
- Field Measurement Data Analysis and Network Improvement Recommendation

#### 4.5 List of Customers:

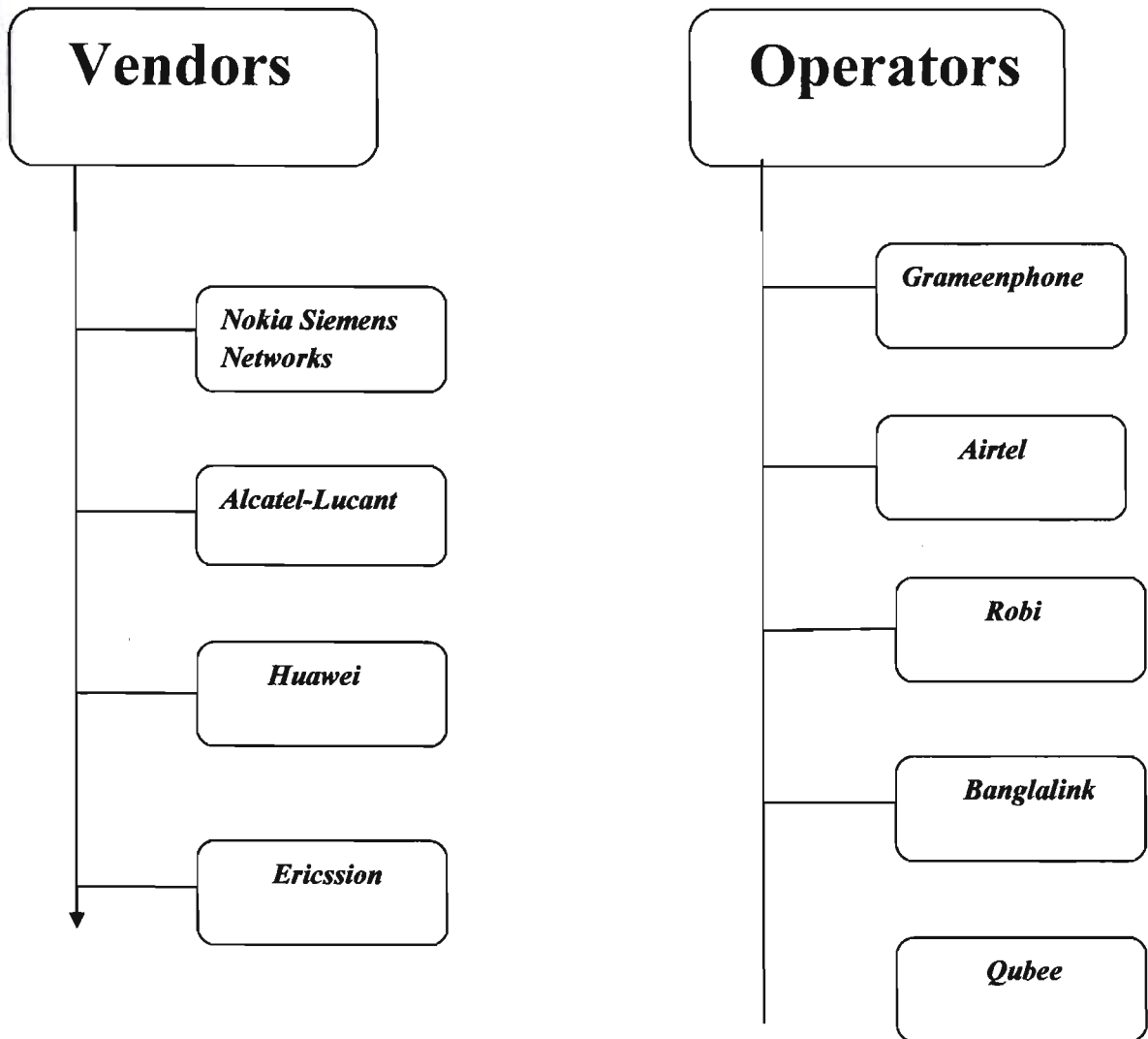

## **4.6 Project Tools**

**METRO TELWORKS LTD.** has inventory of in house wireless test tools to perform services like TSS, LOS, model tuning, drive testing and network benchmarking. We provide tools rental services as well; Our Drive Test tools includes:-

- TEMS Investigation version 7.1/7.0/5.x
- NEMO Outdoor for GSM/GPRS/EDGE/3G/HSDPA
- DTI See Gull scanning receiver
- Agilent E7476A W-CDMA Drive Test System
- Sagem Test Mobiles OT4xx series for GSM/GPRS/EDGE
- NEMO HSDPA Indoor with Merlin XU870 7.2 Express Card



#### 4.7 Technologies

Welcome to METRO TELWORKS LTD.'s Knowledge Center. Here, we provide brief descriptions on the technologies we can find them in most countries. This is also where our strengths are, providing complete services from task based consultancy to full turnkey network deployment.

- GSM
- GPRS
- EDGE
- TETRA
- UMTS/WCDMA
- CDMA

## **Chapter 05**

### **Drive Test**

Drive-testing plays an important role in creating and maintaining a strong GSM network. In mobile communication system drive testing should be used to collect real-time RF information from the field. Generally this is done using a vehicle, but it can also be carried out on foot where circumstances dictate (like inside a building for IBS Testing).

In any case, keeping mobile phone network optimized is vital. Changes in the environment continually affect network performance. Operator can't afford to have unhappy subscribers because there are holes in their coverage or because interference is causing dropped or blocked calls. To migrate to new technologies and applications operators need a drive-test system that will expand with their needs.

### **5.1 The Purpose of Drive Testing**

Drive testing is principally applied in both the planning and optimization stage of network development. However, there are other purposes for which drive testing can be used:

- To provide path loss data for initial site survey work
- To verify the propagation prediction during the initial planning of the network.
- To verify the network system parameters.
- To provide the initial test parameters used in Benchmarking.
- To verify the performance of the network after changes have been made e.g. when a new TRX is added; the removal or addition of a new site; any power adjustments or changes to the antenna; any changes in clutter or traffic habits.
- To measure any interference problems such as coverage from neighboring countries.
- To locate any RF issues relating to traffic problems such as dropped or blocked calls.
- To locate any poor coverage areas.
- To monitor the network against a slow degradation over time, as well as monitoring the network after sudden environmental conditions, such as windstorm or electrical storms.
- To monitor the performance of a competitor's network.

## 5.2 When to Drive Test

Drive testing can take place during the day or at night and is dependent upon the Operator's requirements and subscriber habits. Drive testing during the day will imitate the conditions as seen by subscribers, but may clog up the network if call analysis is being performed. Drive testing during the night will allow a greater area to be surveyed due to the reduction in vehicular traffic jam. It will also allow for certain test signals to be transmitted and tested, particularly when setting up a new site, without interrupting normal operation. However, night-time testing does not imitate the conditions experienced by subscribers. For planning purposes, drive testing is typically performed at night and for maintenance purposes, drive testing is performed during the day.

## 5.3 Where to Drive Test

Some areas of a network will have greater performance problems than others. Drive testing should not be regular throughout the whole network, but should be weighted towards areas where there are significant RF problems. There may be other areas of the network that require temporary coverage during a certain time of the year e.g. an exhibition centre or a sports stadium. These areas should be examined and planned in greater detail. Sometime operators can perform drive test for their customary check for a certain city or some specific clusters of a city.

## 5.4 Types of drive Test

Drive test can be performed in very many ways. Different types of drive test fulfill different types of requirement from the customer.

- Single site Drive Test
- Cluster Drive Test

- Acceptance Drive Test
- Site Swapping Drive Test
- Benchmarking Drive Test
- Functionality Test
- Walk Test for IBS

## 5.5 Tools (Drive Test Kit)

Drive testing needs some distinctive type of tools, like some special mobile phones and software. The followings are list of tools generally required for drive test:

### Hardware:

#### 1. Drive test vehicle

Four wheeler vehicles are perfect for drive test to access important but tough access roads or muddy roads.

#### 2. Power Inverter

This device inverts DC power to AC power. We can use it to invert vehicle's DC power to AC power to ensure uninterrupted power supply to the laptop and other electronic devices during DT.

#### 3. Laptop computer

DT laptop should be with good condition and configuration, like high speed processor and especially RAM volume should be more for smooth drive testing.

#### 4. Mobile phones and phone charger

Special mobile phones designed with field measurement features. How many mobile phone should we use during DT depends on the types of DT. Some testing requires one phone and some other requires two or more. Chargers are also compulsory to keep the phone always charged.

#### 5. Data cables

Data cable depends upon the model of the mobile phone. Every mobile phone has its own data cable to transfer measured data to the software installed in the laptop.



## **6. External antennas**

Every mobile phone should be connected with external antenna during DT. Generally when we use mobile phones inside the car during DT, there is an enormous possibility to get poor field data. External antenna can minimize this problem. Usually it is attached on top of the vehicle using a magnetic base.

## **7. Car GPS**

GPS generally used for positioning purpose. In DT positioning is very important both for visualization (current position during DT) and analytical point of view. Car GPS also attached on top of the vehicle like external antenna and connected with laptop through cable.

## **8. Dongle (Key for DT software)**

One of the most important hardware for drive test is Dongle. Every drive test software needs the key to run during DT. Physically it looks very similar to a pen drive.

## **9. USB Hub**

Sometime when we need to work with two or more mobile phones then we need more USB ports, but our laptop ports are limited. So we have to use USB hub or PCMC USB card, which will provide us more USB ports to connect more equipment.



CAR GPS

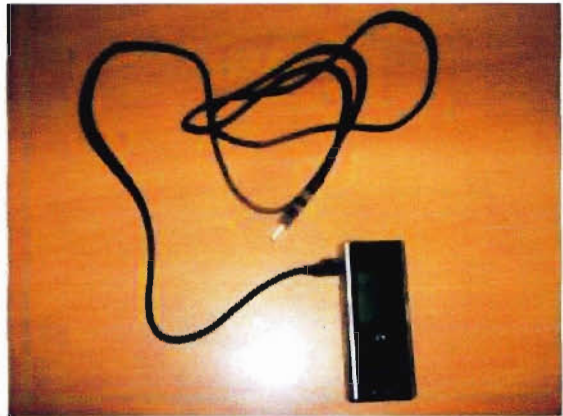

MOBILE PHONE WITH DATA CABLE



DONGLE ( LICENSE )



( EXTERNAL ANTENNA )



USB HUB



POWER INVERTER



LAPTOP, CONNECTED WITH ALL THE TOOLS

## 5.6 Software and necessary files:

### 1. Data collection Software

This is the software through which field data will be collected. With this software we can analyze the field data also. This software should be licensed from the vendor company for proper authorization. Every software has a key to work properly. The most popular software for data collection is “**TEMS Investigation**” from ERICSSON.

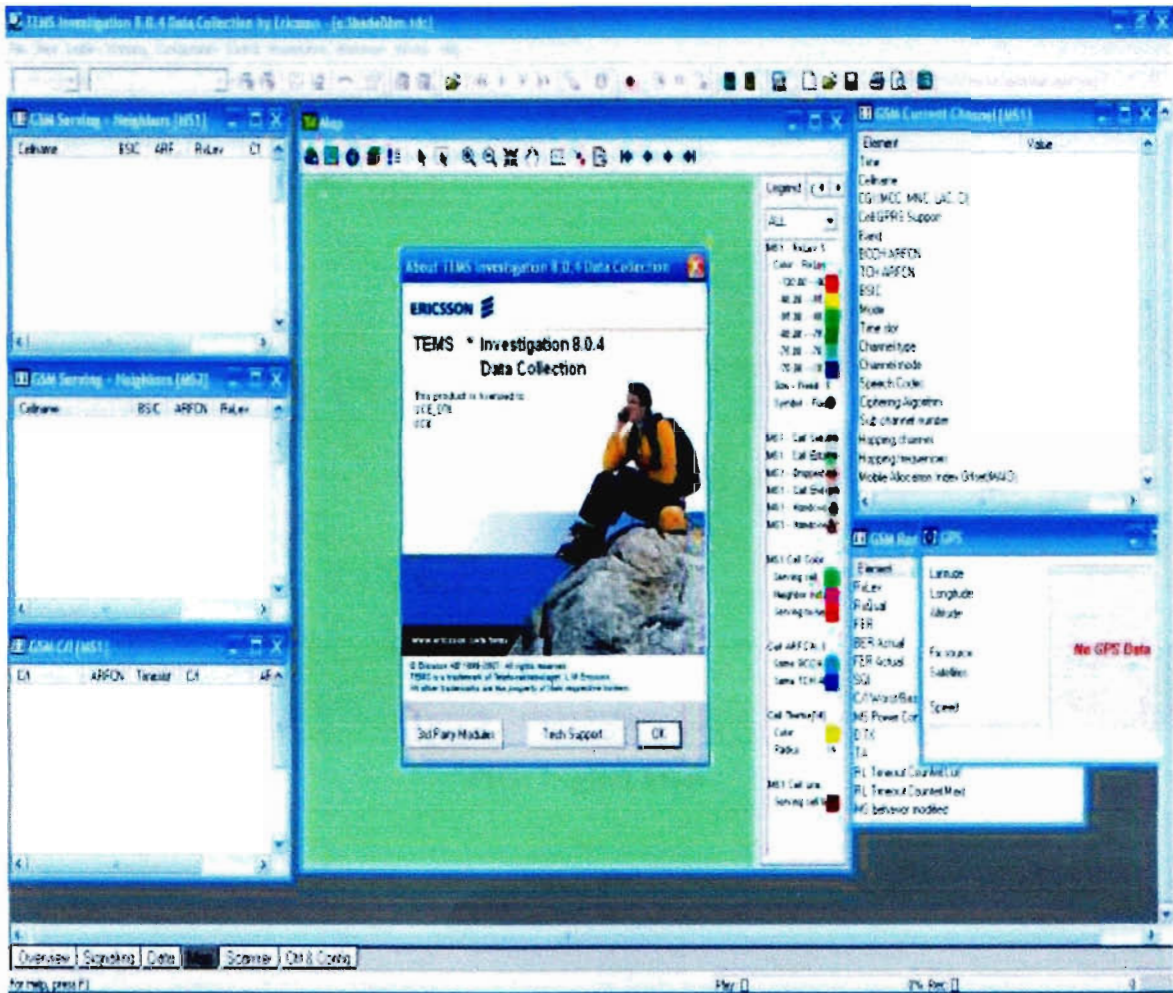

**Fig: TEMS data collection software**

## 2. Digital Map

During drive test digital map is necessary for finding the way to reach the selected site/cluster and do DT according to some predefined routes. We can load the digital map of the whole region or we can load the map of some specific roads that need drive test. This map comprises all the accessible DT routes.

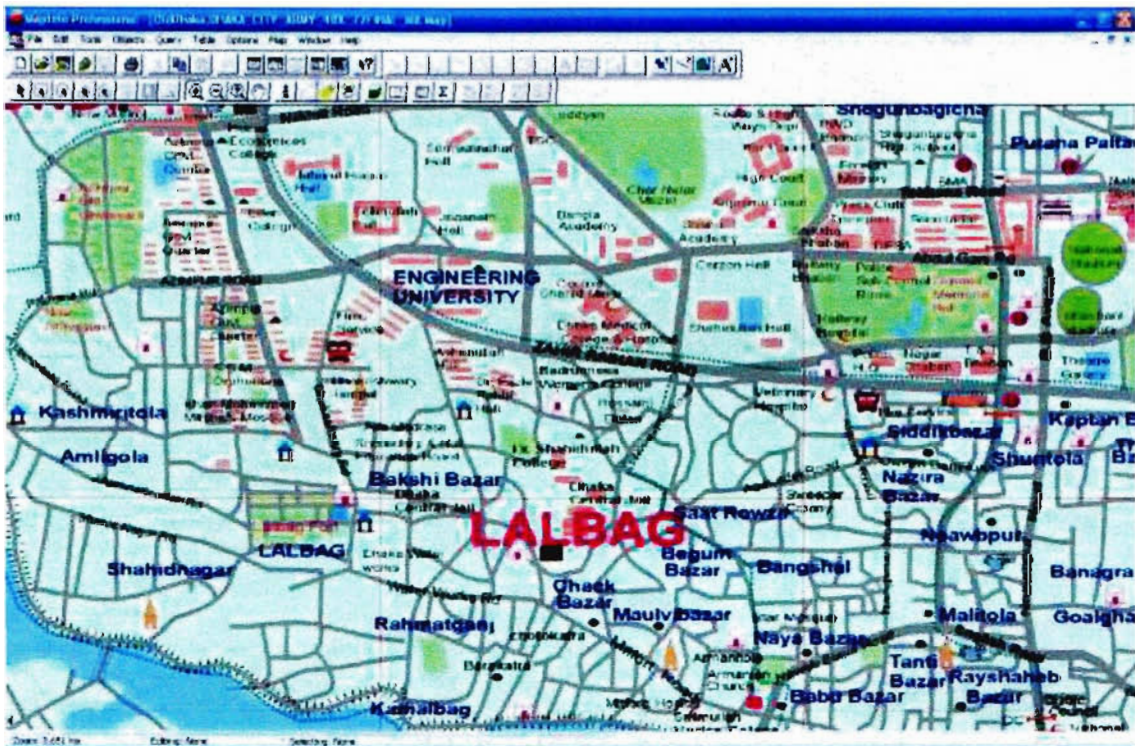

FIG: Digital Map

### 3. Cell file

We must load the cell file into the data collection software. A cell file contains all the necessary information related to the site, like ID of that site, assigned frequencies of that site, direction of the antennas of that site etc. Whenever we load the cell file we can see the position of that site in the digital map. Then we can easily find out our required sites form the map and also the roads to be covered for that site.

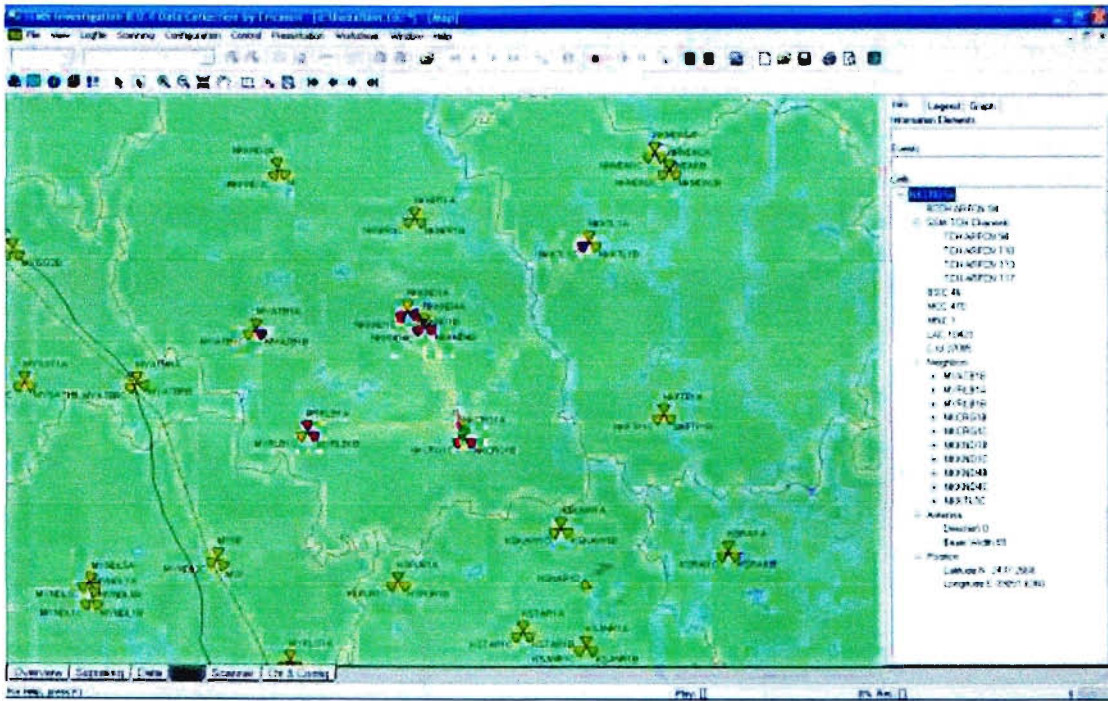

FIG: Cell file

#### 4. MapInfo

MapInfo allowed us to include mapping functionality into DT software. We can easily plot our sites position, routes, and building drawings (for indoor test) with this software. MapInfo has the ability to combine and display, on a single map, data from a variety of sources that are in different formats and projections. The software is capable of overlaying vector layers on the same map.

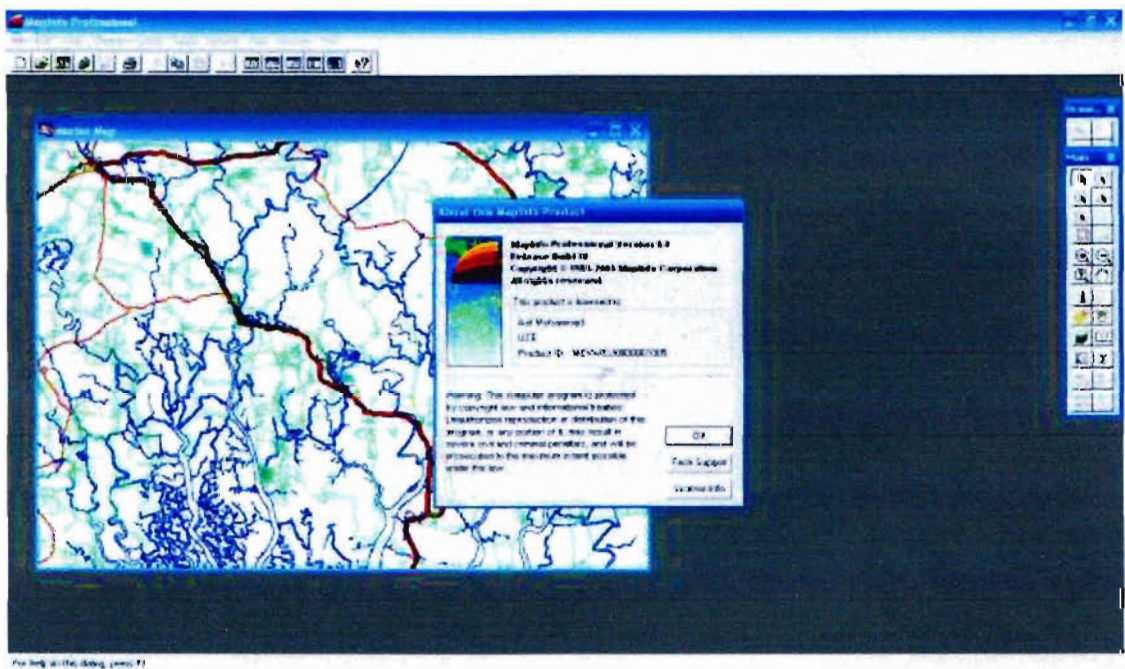

FIG: MapInfo Software

#### 5. Drivers

All the mobile phones and GPS need driver software to synchronize with the drive test software. Every equipment drivers must be installed properly in the laptop otherwise they will not work properly.

## **Chapter 06**

### **Functionality Test**



## 6.1 Procedure of Functionality Test

In Swap Night, the RF engineers have to do the Functionality Test for the purpose of monitoring the network performance of the new equipments of a BTS. Functionality Test consists of some test named as :

- Call Set-up
- Long Call/ Short Call
- Basic Handover
- Data Test
- Possible Feeder Swap etc.

To do the Functionality Test RF engineers have to maintain some files such as :

- DT Route
- Cell File
- Cluster Boundary
- Parameter List
- Team Plan
- Night Duty BSC Engineers contact Number

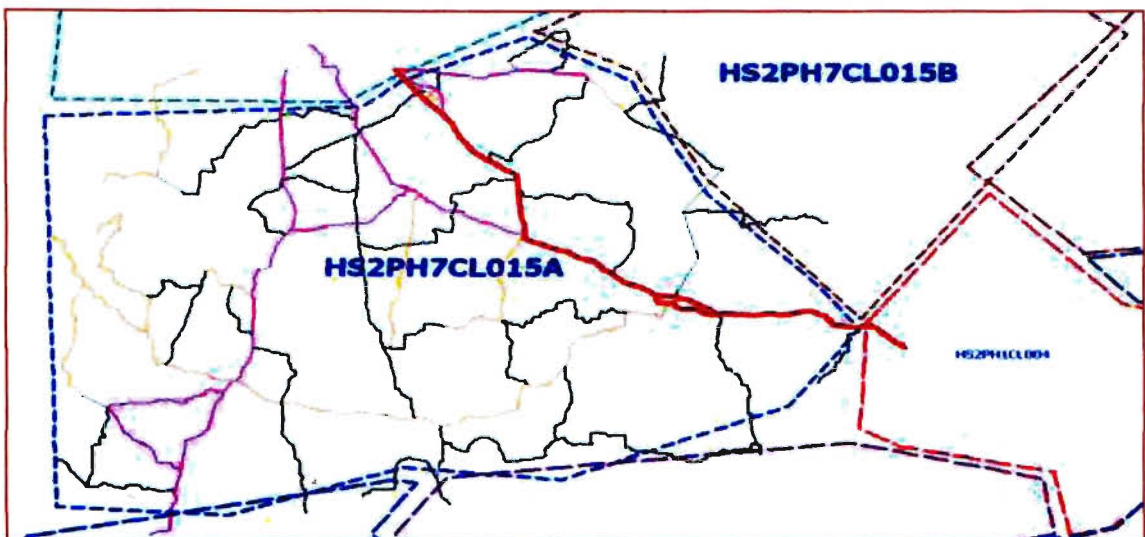

DT Route

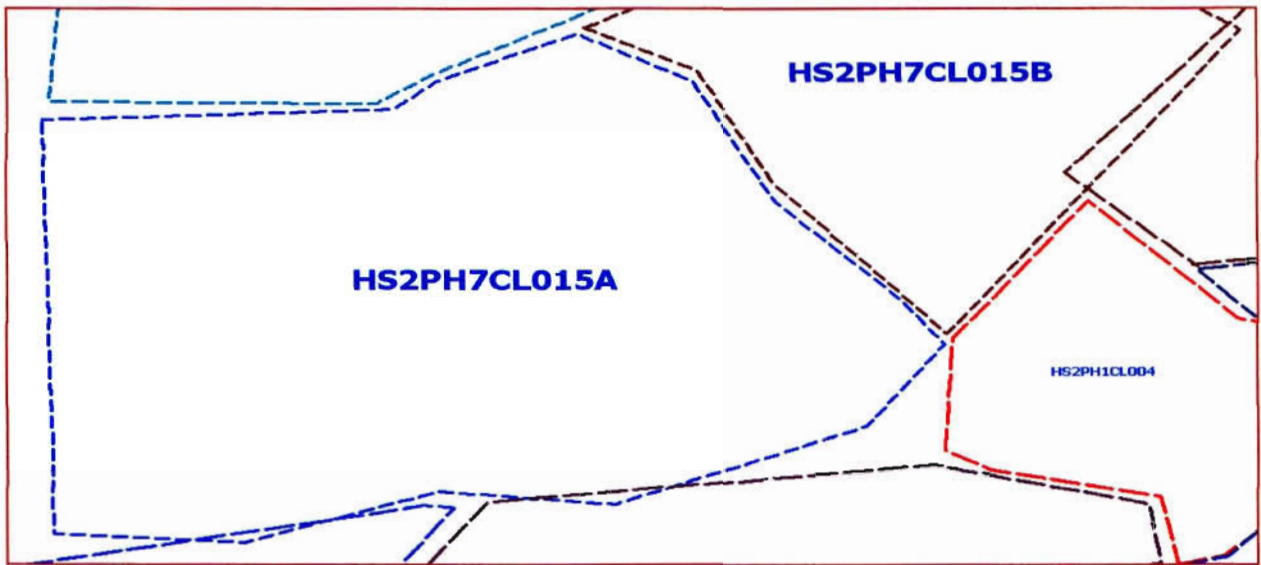

Cluster Plan

**Pre Test Preparation :**

- Verify from BTS or BSC personnel if the site is up and running.
- Collect the parameters for the cell/sector(s) under test from the RF Planning team. Verify that the BCCH & NBCCH frequencies, MAIO list, Handover candidates, HSN, BSIC, and other parameter values set in the BSC are correct
- Verify that the BCCH frequencies are loaded into the mobile monitoring software (TEMS Cellfile) for cell/sector(s) under test. The TEMS may need to be configured or reconfigured as cells/sectors are added or any change in frequency plan.
- Obtain the MSC test number to be used for testing (record in data sheet).
- Obtain the drive van, GSM phone number and GSM IMEI of SIM to be used for testing (record in data sheet).
- At Site, Verify the orientations of antennas, antenna heights, antenna types and if possible, tilts. These observations may be made with the help of a pair of binoculars and a compass. These observations should be recorded in the SSFT record sheet.
- Determine the initial start/stop points on the map for each cell/sector(s) under test. The start/stop points should be approximately 0.5 km. or less away from the site, close to the center of the sector within the coverage of the sector/cell under test.
- Determine the preliminary circular drive route around the cell, which intersects each start/stop point for each sector. This route should represent the area of the GSM site coverage to be tested.

- Verify the van setup (like cigarette lighter, inverter, software installed on the laptop, proper cables, PCMCIA card if required)
- Turn the drive test laptop computer ON and bring up the Test software and ensure GPS is tracking.

The Pictures of proper handover,

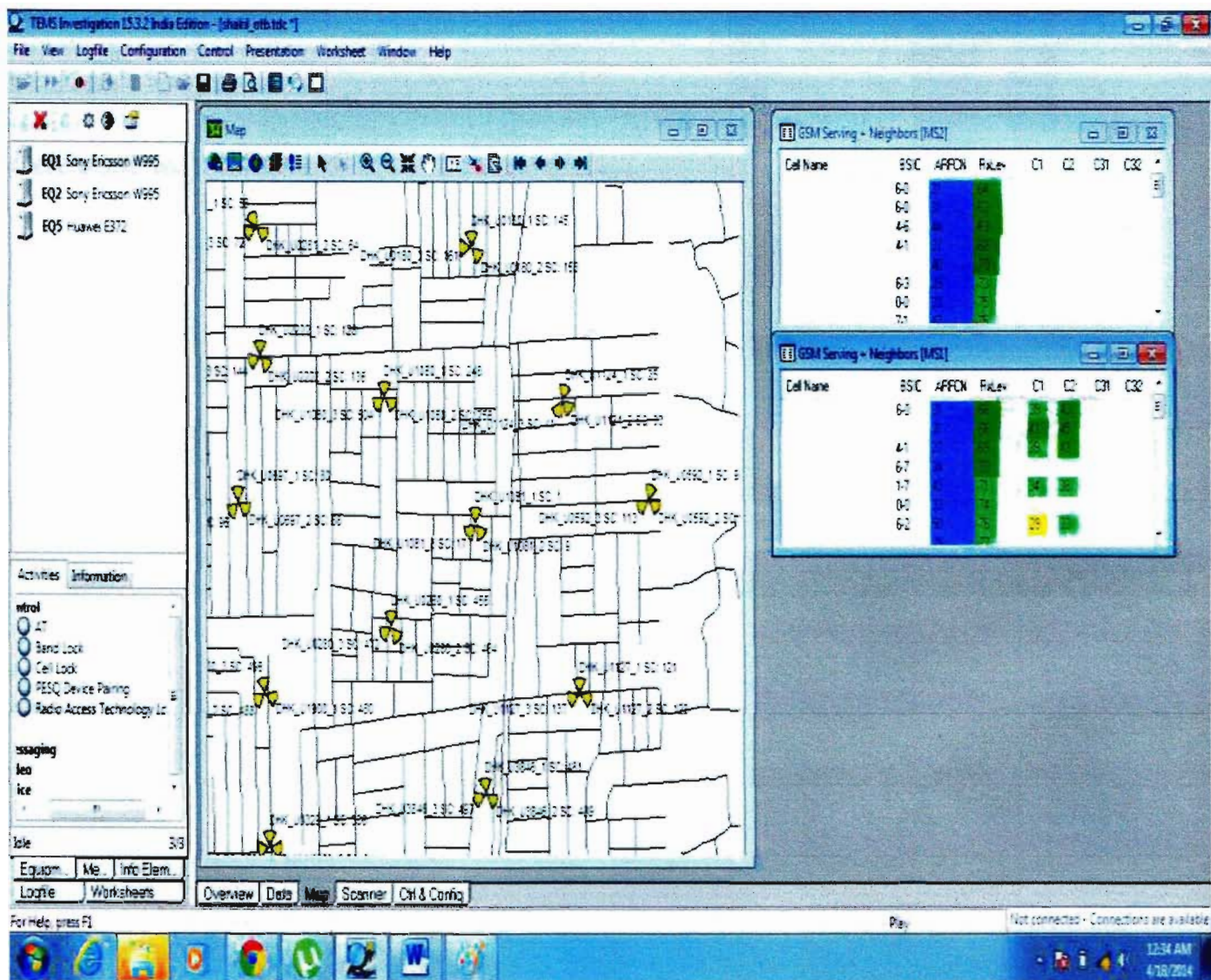

The screenshot displays the TEMS Investigation v3.2.2 interface. The central window shows a map of a GSM network with various cell sites marked by yellow icons and labeled with identifiers like 'CHN\_1012\_1 SC 148'. The left sidebar contains a list of equipment models: EQ1 Sony Ericsson W995, EQ2 Sony Ericsson W995, and EQ3 Huawei E372. Below this, there are sections for 'Activities' and 'Information' with various radio-related options like 'AT', 'Band Lock', and 'Cell Lock'. The right side of the interface features two 'GSM Serving - Neighbors [MSX]' panels, each displaying a table of neighboring cells with columns for CellName, BSC, ARFDV, Pklev, D1, D2, C0, and C3. The bottom of the window shows a Windows taskbar with the system clock at 12:29 AM on 4/18/2014.

## **Chapter 07**

### **Conclusion**

In conclusion I have to attest my supervisor Gopal Chandra Gope of Metro Telworks Ltd. I really appreciate the way I have been guided through this internship program with Metro Telworks Ltd., beginning from the opportunity to take the time I needed to refresh and expand my knowledge in several issues concerning Drive Test, over a somehow protected period where I could discover and learn to value my new working environment, and finally earned the confidence to deal with assignments myself. It is through them that I did enjoy my work every day. Having a rare opportunity to use the knowledge and skills that I had acquired, I learned how to handle critical network faults and got the new ideas.

Career-wise, the internship program undoubtedly will enrich my curriculum vitae (CV). Also, having gotten a chance to interact with most staff, I have had an insight on how to shape my career towards a humanitarian job in the near future.

The internship program gave me a chance not only to work with Metro Telworks Ltd. but also a chance to learn from the good experts. This would reflect much onto my experience. Working with different business organizations was a rare chance for me.

## **References**

1. [www.google.com](http://www.google.com)
2. [www.metrotelworks.com](http://www.metrotelworks.com)
3. [www.wikipedia.com](http://www.wikipedia.com)
4. [www.wikianswer.com](http://www.wikianswer.com)
5. Regular employees of Metro telworks
6. Metro telworks IT Division Documentation
7. Annual report 2013, spring.