



# Power Line Communication System for Smart Metering Networks

## **Supervised By:**

Zahidur Rahman (Lecturer)

Department of Electronics and Communications Engineering

East West University

Dhaka, Bangladesh

## **Submitted By:**

**Name:** Anim Sarker

**ID:** 2019-1-55-003

Department of Electronics and Communications Engineering

East West University

Dhaka, Bangladesh

This Intern Report is submitted in Partial Fulfilment of the Requirements of the

Degree of Bachelor of Science in

“Electronic & Telecommunication Engineering”,

Department of Electronics & Communications Engineering

**EAST WEST UNIVERSITY**

# Approval

The intern report titled “Power Line Communication System for Smart Metering Networks” submitted by Anim Sarker (ID: 2019-1-55-003) to the Department of Electronics and Communications Engineering, East West University, Dhaka, Bangladesh has been accepted as satisfactory for the partial fulfilment of the requirements for the degree of Bachelor of Science in Electronic and Telecommunication Engineering and approved as to its style and contents.

Approved By

---

Supervisor

Zahidur Rahman

Lecturer

Department of ECE

East West University

Dhaka, Bangladesh

# Declaration

I declare that our work has not been previously submitted and approved for the award of a degree by this or any other University. As per our knowledge and belief, this thesis contains no material previously published or written by another person except where due reference is made in the thesis itself. I hereby declare that the work presented in this thesis is the outcome of the investigation performed by us under the supervision of Zahidur Rahman, Lecturer, Department of Electronics & Communications Engineering, East West University, Dhaka, Bangladesh.

Countersigned

---

Supervisor

Zahidur Rahman

Signature

---

Anim Sarker

ID: 2019-1-55-003

## **Acknowledgments**

It is my pleasure to acknowledge the extra-ordinary supervision, invaluable suggestion, and proper guidance of my supervisor **Zahidur Rahman**, Lecturer, Dept. of Electronics and Communications Engineering, East West University and my respectable trainer **Engr. Mohammad Emdadul Haque**, Manager, ICT Development Circle, Dhaka Power Distribution Company Limited (DPDC), from whom I have been very much benefitted throughout the course of our training. I express my humble gratitude to them. Without their kind cooperation and help the internship report would never have been possible.

I am also thankful to our honorable teachers of the Department of Electronics and Communications Engineering (ECE) at East West University (EWU) and well-wishers for their valuable suggestion during the period of our internship work.

Finally, I would like to express my indebtedness to my parents for their constant support and inspiration to accomplish the job.

# Certification



ঢাকা পাওয়ার ডিস্ট্রিবিউশন কোম্পানী লিঃ  
DHAKA POWER DISTRIBUTION COMPANY LTD (DPDC)  
(An Enterprise of the Government of the People's Republic of Bangladesh)  
Website: [www.dpdc.org.bd](http://www.dpdc.org.bd)

Office of the  
Superintending Engineer  
Training & Development  
Training Bhaban, 6th Floor  
Katabon, Dhaka-1000  
Phone: 9670731, Fax: 8616738  
e-mail: [setd@dpdc.org.bd](mailto:setd@dpdc.org.bd)

স্মারক নং: ৮৭.৪১০.৪৫০.০৬.০০.০৭৯.২০২২.১৩৮

তারিখ: ৩০/০৮/২০২২ খ্রি.



Associate Professor & Chairperson  
Department of Electronics and Communications Engineering  
East West University  
Dhaka, Bangladesh

বিষয়: **East West University** এর ০৮ জন শিক্ষার্থী ডিপিডিসি'তে ইন্টার্নশীপ ট্রেনিং এ অংশগ্রহণ প্রসঙ্গে।  
Memo No: 87.410.450.06.00.079.2021.994 Date: 16/06/2022

বর্ণিত বিষয়ে জানানো যাচ্ছে যে, East West University এর ECE ডিপার্টমেন্ট এর নিম্নবর্ণিত ০৮ জন শিক্ষার্থী ডিপিডিসি'তে গত ১৯/০৬/২০২২ হতে ৩০/০৮/২০২২খ্রি. পর্যন্ত এটাচমেন্ট ট্রেনিং এ অংশগ্রহণ করেন।

Sl. No.	Student Name	Technology	Student ID	Mobile No.	Institute
01	Kazi Jannatara Juti	B.Sc in ECE	2019-1-55-001	01706478205	East West University
02	Anim Sarker	B.Sc in ECE	2019-1-55-003	01756910902	
03	Mashfique Uddin Bhuiya	B.Sc in ECE	2019-1-55-008	01765146863	
04	Md. Mobashir Hossain	B.Sc in ECE	2019-1-55-009	01880834131	
05	Md. Nazmul Houqe Nayem	B.Sc in ECE	2019-1-55-015	01749723239	
06	Md. Abu Sayem Rishad	B.Sc in ECE	2019-1-55-026	01521572297	
07	Maimanah Binte Jahangir	B.Sc in ECE	2019-1-55-027	01780234185	
08	Ahnaf Muttaque	B.Sc in ECE	2019-2-55-009	01719695456	

ইন্টার্নশীপ ট্রেনিং এ নিম্নলিখিত বিষয়ে আলোকপাত করা হয়:

- বিদ্যুৎ সরবরাহের সূচনা, বিদ্যুৎ সেক্টরের রিফর্মের আওতায় সরকার কর্তৃক ক্রমাগত পিডিবি, আরইবি, ডেসা, ডেসকো ও ডিপিডিসি গঠন।
- ডিপিডিসি'তে বিদ্যুৎ সরবরাহ ব্যবস্থা।
- ডিপিডিসি'তে নেটওয়ার্ক অপারেশন ও কাস্টমার সার্ভিস (এনওসিএস) কার্যক্রম।
- এনওসিএস এর সহায়ক অফিসসমূহের (যেমন- এইচ.আর, ফিন্যান্স, আইসিটি, অডিট, পরিকল্পনা, উন্নয়ন, মিটারিং, সিস্টেম প্রটেকশন, গ্রীড, ট্যারিফ এন্ড এনার্জি অডিট) কার্যক্রম।
- ডিপিডিসি'র প্রশিক্ষণ ও উন্নয়ন দপ্তরের কার্যক্রম।
- ১৩২/৩৩ কেভি জিআইএস উপকেন্দ্র ও ৩৩/১১ কেভি উপকেন্দ্র পরিদর্শন।
- ডিপিডিসি'র স্ক্যাডা সিস্টেম, ওয়ার্কশপ, মিটার টেস্টিং ল্যাব, কেন্দ্রীয় ভান্ডার, মেডিকেল সেন্টার পরিদর্শন।

শিক্ষার্থীদের উত্তরোত্তর সাফল্য কামনায়,

  
(মোঃ মহিউল আলম) ৩০/৮/২২

তত্ত্বাবধায়ক প্রকৌশলী  
প্রশিক্ষণ ও উন্নয়ন, ডিপিডিসি।

ই-মেইল: [setd@dpdc.org.bd](mailto:setd@dpdc.org.bd)

বিতরণ:

- নির্বাহী পরিচালক (এডমিন ও এইচ.আর), ডিপিডিসি।
- সিসিও টু ব্যবস্থাপনা পরিচালক মহোদয়, ডিপিডিসি।

## Abstract

Power Line Communication (PLC) in Bangladesh has been extrapolated from many technical research papers and recent trade publications. The purpose of this study is to identify powerline communication components critical to the deployment of indoor and outdoor applications and consumer communications during the global commercial development of various potential services. Considerations include potential service, bandwidth, coverage area, quality, reliability, and cost. Electricity grids, with their more decentralized structure and unpredictable availability than their traditional counterparts, have undergone major changes on the generation side in recent years as the use of energy sources (renewables) increases. In the same way that the spread of electric vehicles will significantly change consumer behaviour. These new conditions require better monitoring and control of grid assets, and smart metering is essential to achieving both goals. Power line communication (PLC) has emerged as a viable alternative in many situations, but there are many communication technologies available for smart metering applications. In addition, it provides a private communications network for distribution system operators (DSOs) and seamlessly integrates sensors and communications capabilities. This intern paper briefly discusses PLCs as they relate to smart meters and the need for powerline communication in Bangladesh as a key component of digital Bangladesh.

**Keywords:** smart metering; smart grid; PLC; broadband (BB); narrowband (NB); ultra-narrowband (UNB); strategy; implementation; distribution grid; Advanced Metering Infrastructure (AMI).

## Table of Contents

Topic	Pg. No.
Approval	01
Declaration	02
Acknowledgments	03
Certification	04
Abstract	05
Table of Contents	06
List of Abbreviations	10
List of Figures	11
Origin of the Report	12
Scope of the Report	13
Methodology	14
Limitations	15
<b>CHAPTER 1 – Introduction</b>	
1.1 Introduction	16
1.2 Background and Analysis	16
1.3 Objective of The Study	17
1.4 Significance of The Study	18
<b>CHAPTER 2 – Background and Literature Review</b>	
2.1 Smart Meter	19
2.1.1 Smart Meter and why it is needed	19
2.1.2 Why Smart Meter is Essential in Bangladesh	20
2.1.3 Benefits of Smart Meters	20

2.1.4 Architecture of Smart Meter	21
2.1.5 Smart Electricity Meter Design	22
2.1.6 Smart meter basic block diagram & operation	23
2.1.7 Smart Meter Communication Network	25
2.1.8 Smart meter tariff calculation	26
2.1.9 Commercial Aspects of Smart Metering	26
2.1.10 Advanced Metering Infrastructure (AMI)	27

<b>CHAPTER 3 – PLC System</b>	
	29
3.1 Classification of PLC technologies	29
3.2 Architecture of PLC System	30
3.3 Operating Principle of PLC System	32
3.4 Major components of PLC System	33
3.4.1 Power Line Channel Characteristics	35
3.4.2 Power Line Network Adapters	35
3.4.3 PLC Modem	36
3.4.4 Modulation & Superimposition	36
3.4.5 Signal Superimposition on Power Lines	37
3.5 Technical Parameters of PLC System	37
3.5.1 Noise on Residential Power Circuit (RPC)	37
3.5.2 Signal to Noise Ratio	38
3.5.3 Signal Attenuation	38
3.6 Implementation of PLC for Smart Metering Systems	38
3.6.1 Grid Description	38
3.7 PLCC in Meter Reading	40
3.8 PLC Performance Assessment	40
3.9 Application of PLC system	41
3.10 Advantages and Disadvantages of PLC System	42
3.10.1 Advantages	42



3.10.2 Disadvantages	43
3.11 Limitations of PLC System	43
3.12 Further Scope	44

<b>CHAPTER 4 – Discussion</b>	
	45
4.1 Smart Metering	45
4.1.1 The Smart Meter	45
4.1.2 Smart Metering Features	45
4.1.3 Benefits to Utility	45
4.2 Challenges of Smart Metering in Bangladesh	46
4.3 Challenges of PLC System for Smart Metering	47
4.4 Commercial Aspects of PLC System	48
4.4.1 Overview of the Power Line Communication (PLC) Systems Market	48
4.4.2 Overview of the Segment	49
4.4.3 Cost-effectiveness as a result of simplified networking	49
4.4.4 Centralized risk	49
4.4.5 Functional areas of PLC beyond AMI	50
<b>CHAPTER 5 – My Experience at DPDC as an Intern</b>	
	51
5.1 About DPDC	51
5.1.1 The Company	51
5.1.2 Vision	51
5.1.3 Mission	51
5.1.4 Commitment	52
5.1.5 Core Objectives	52
5.2 Ongoing Projects of DPDC	52
5.3 Completed Projects of DPDC	53
5.4 Visiting Sites	54
5.5 Real Life Data and Scenario of PLC System under DPDC	56

<b>CHAPTER 6 – Conclusion &amp; Future Prospects</b>	<b>57</b>
6.1 Conclusion	57
6.2 Future Prospects	58
References	59

## **List of Abbreviations**

DPDC	Dhaka Power Distribution Company Limited
ICT	Information & Communication Technology
DSO	Distribution System Operator
PLC	Power Line Communication
AMR	Automatic Meter Reading
AMI	Advanced Metering Infrastructure
DSM	Demand Side Management
PWM	Pulse Width Modulation
DSL	Digital Subscriber Line
IoT	Internet of Things
RF Mesh	Radio Frequency Mesh
NB	Narrowband
UNB	Ultra-Narrowband
HDR	High Data Rate
LDR	Low Data Rate
BB	Broadband
EMI	Electromagnetic Interference
LV	Low Voltage
MV	Medium Voltage
NOCS	Network Operation & Customer Service

## List of Figures

FIGURES		PG. NO.
FIGURE - 1	Architecture of Smart Metering System	21
FIGURE - 2	Software architecture of a conventional meter, showing communications with other meter components	22
FIGURE - 3	Smart meter working methodology	22
FIGURE - 4	System block diagram of a smart electricity meter showing all the parts of the metering system	23
FIGURE - 5	Basic block diagram of a smart energy meter for electricity consumption	23
FIGURE - 6	System diagram showing the information flow during communication	24
FIGURE - 7	AMI Infrastructure for Smart Meter	27
FIGURE - 8	AMI System Architecture	28
FIGURE - 9	Architecture of PLC System	31
FIGURE - 10	Diagrammatic Representations of the Working Mechanism of PLC	32
FIGURE - 11	Line Trap Unit in Substation	33
FIGURE - 12	Coupling Capacitor in Substation	33
FIGURE - 13	Lightning arrester	34
FIGURE - 14	Line matching unit	34
FIGURE - 15	An Image of PLC Transceiver	36
FIGURE - 16	Automatic Meter Reading System Components and Interconnection between them	40
FIGURE - 17	SCADA Visit	54
FIGURE - 18	Dhanmondi Substation Visit	55
FIGURE - 19	Grid North-2 Visit	55
FIGURE - 20	Biddut Bhaban, BPDB, Dhaka	56
FIGURE - 21	Data of PLC implementation under DPDC	56

## Origin of the Report

Internship Program of East West University is a Graduation requirement for the B.Sc. students. This report is a partial requirement of the Internship program of B.Sc. curriculum at the East West University. The main purpose of internship is to get the student exposed to the job world. Being an intern the main challenge was to translate the theoretical concepts into real life experience.

The internship program and the study have following purposes:

- To get and organize detail knowledge on electricity transmission.
- To experience the real job field.
- To compare the real scenario with the lessons learned in East West University
- To fulfil the requirement of B.Sc. Program.

This report, which is being prepared as part of an East West University B.Sc. program requirement, is the outcome of a three-month internship program at Dhaka Power Distribution Company Limited (DPDC). The "Power Line Communication System for Smart Metering Networks" is the subject of the report I must submit. The services and activities of DPDC, an overview of the company, and services provided to customers are all covered in this report.

## **Scope of the Report**

The main intention of the report is to identify prospects & challenges of Power Line Communication System for Smart Metering generation in Bangladesh and to get a clear picture of the opportunities we have in order to meet our smart metering policy through power supply companies.

This report covers details about the generation, installation & maintenance of PLC system whether grid-connected or not. Main focus was on the analysis of the electricity transmission, implementation, and availability of smart metering, prospects of installing PLC system even in a densely populated city like Dhaka. However the study is mostly related to the PLC & Research as I was provided an opportunity to work under this office of DPDC.

The report's scopes are followed below:

Information for the analysis was collected from the company's internal sources, websites, database, research papers & study materials.

Geographic scope of this report is limited to DPDC held area in Dhaka city.

## **Methodology**

From topic selection to final report preparation, the study is carried out according to a systematic process. Identification and data collection played a crucial role. After that they were classified, analysed, interpreted and presented in a systematic manner to find the vital points. The overall methodology used in the study is described in more detail.

### **Selection of the topic:**

My supervisor assigned the topic of the study. Before the topic was assigned it was thoroughly discussed so that, a well-organized internship report can be prepared.

### **Sources of Data:**

#### **Primary Sources:**

Primary Data was derived from the practical deskwork. Moreover, my industrial supervisor at DPDC also helped me to get information directly from the company.

#### **Secondary Sources:**

**Internal sources:** Different documents provided by concerned officers and different circulars, manuals and files of the organization.

**External source:** Different websites related to renewable energy and online resources.

### **Classification, analysis, interpretations and presentation of data:**

In order to analyse the data gathered and to more clearly explain certain concepts and findings, some diagrams and tables were used in this report. Furthermore, the collected data underwent a more thorough analysis.

### **Findings of the study:**

The collected data were analysed well and were pointed out and shown as findings at the end.

### **Final report preparation:**

The final report is prepared after valuable suggestions and advice of my honourable advisor.

## **Limitations**

My working area was mostly the office of training centre and ICT division of DPDC. Being new to the workplace, it was initially challenging to comprehend the process and the applicability of DPDC's involvement in the PLC System. Time limitations were another issue. Due to time limitations, analysing large amounts of data was difficult enough. My work only lasted for three months. However, this amount of time is insufficient for a thorough and understandable study. Therefore, there could be some unexpected errors in the report. Despite numerous restrictions, I tried my best to complete the report.



# Chapter 1: Introduction

## 1.1 Introduction

Powerline Communication or Powerline Carrier (PLC) is also known as Powerline Digital Subscriber Line (PDSL), Mains Communication, Powerline Telecom (PLT), Powerline Networking (PLN), or Broad Band over Power Lines (BPL). A conductor for the transmission of electrical energy. Electricity is transmitted on high voltage lines, distributed at medium voltage and used inside buildings at low voltage. Powerline communication can be applied at any stage. Most PLC technologies are limited to one set of cables (such as building wiring), but some span two tiers (such as both distribution networks and building wiring). Transformers typically prevent signal propagation and allow multiple PLC technologies to be bridged to form very large networks. In general, power grids can be broadly classified into three categories.

Use of DC power supplies in industrial applications such as the automotive industry. Sine wave supply for distribution networks or domestic applications. Pulse width modulation (PWM) networks used in most converter and actuator applications.

Powerline communication (PLC) technology is widely used in sinusoidal and continuous electrical networks, guaranteeing data rates up to hundreds of megabits per second. These PLC modems will not work on PWM networks that inherently occupy the spectrum abroad. This seminar will therefore provide an overview of PLC technology and its operational limitations over PWM networks. Based on a detailed study of the inverter spectrum, a new PLC modem is designed specifically for PWM networks. The performance of these modems is evaluated in terms of transmission security and data rate. This technology eliminates the need for additional cables between actuators and converters, potentially offering price and size advantages.

## 1.2 Background and Analysis

Power Line Carrier (PLC) is a method of transmitting data over an electrical power distribution network. This technology allows information to flow through the same cable that supplies power. This novel method of information transmission connects the electrical and communication networks. In most PLCs, the same electric cables used for power delivery are also used for communication. A high-pass filter called a coupling interface separates the powering and signalling circuits. The coupling interface allows you to connect circuits with varying voltage levels. Because the power line is designed for power transmission at 50/60 Hz

and mostly at 400 Hz, the use of this medium to transmit data (particularly at high frequencies) poses some technically difficult problems. It is one of the most electrically contaminated environments, making data signal transmission difficult. High noise levels and uncertain (or varying) levels of impedance and attenuation characterize the channel. Furthermore, in comparison to cable or fiber-optic links, the line has a limited bandwidth. Power line networks are typically constructed from a variety of conductor types and cross sections that are joined almost at random.

As a result, the network encounters a wide range of characteristic impedances. This also complicates the design of filters for carrier communication networks. There are numerous factors that influence the reliability of a power line carrier (PLC) channel. However, the goal is to obtain a signal level in the remote terminal that is greater than the receiver's sensitivity and has a signal-to-noise ratio (SNR) that is greater than the minimum, so that the receiver can make a correct decision based on the transmitted information. If both of these requirements are met, the PLC channel will be reliable.

AMR (Automated Meter Reading) is a technology that allows utilities to obtain meter-reading values remotely rather than physically visiting and manually reading a customer's electric meter. Electric energy meter readings can be transmitted using the PLC (Power Line Carrier) protocol. The AMR system begins at the meter, where readings from rotating meter dials or cyclometer style meter dials must be converted into digital form in order to send digital metering data from the customer site to a central point.

### **1.3 Objective of the Study**

In this internship study I worked on power line communication. Through this study I wanted to show how power line communication plays an important role in smart metering. Also we have discussed its functions, advantages, disadvantages, required components.

More specifically, this study entails the following aspects:

- To give an overview of smart metering system of Bangladesh.
- To focus on the Powerline System in order to meet smart metering and electricity supply.
- To identify prospects & challenges of PLC System in Bangladesh.

#### **1.4 Significance of the Study**

This system is significant in smart metering because it enables efficient and cost-effective smart meter network deployment. PLC allows utilities to avoid the need for new communication infrastructure, such as separate communication lines or wireless networks, which can be time-consuming and costly to install. The PLC system allows for real-time monitoring and control of energy consumption, resulting in better energy management and lower costs for utilities and consumers alike.

In this study I have discussed the architecture of power line communication to its deployment, requirements, costs, limitations, challenges, categories, components etc. in smart metering. I believe this report will play a very important role in future work on power line communication and smart metering.

## Chapter-2: Background and Literature Review

### 2.1 Smart Meter

#### 2.1.1 Smart Meter and why it is needed

**Smart Metering Concept:** Many countries are introducing smart meters for various utility supplies. Because consumers and customers will already have meters installed, the roll out will be gradual, but steady, and will take place in many countries. Smart energy meters can be used for utilities such as electricity, gas, and even water that need to be connected and metered. Smart meters enable utility companies to remotely monitor usage without the need for meter readers to visit or customers to provide readings, and they can also provide insights into usage to help utility networks run more efficiently. This is a significant benefit when all countries are attempting to reduce their environmental impact. One critical aspect is that the electricity usage data provided enables the implementation of a smart grid that will deliver energy more efficiently and with less environmental impact. Furthermore, the smart energy meter typically provides users with information on their current and historical consumption. This allows the user to monitor and adjust their consumption, increasing the likelihood of being able to reduce consumption and thus become more economical in the use of electricity, gas, water, and so on. The possibilities for smart meter designs are extremely diverse. Often, countries or regions will develop their own standard for smart meter format, allowing the meters to be tailored to the region's needs, communications system, and so on. A common standard can also help when there are multiple energy suppliers and consumers want to switch between them. Because installing a smart meter necessitates disconnecting the energy supply and installing a new meter in line, the installation can be costly in addition to the meter's cost.

#### Why Smart Meter is needed?

1. Scheduled / On-demand Meter data reading at configurable intervals
2. Remote Disconnection / Reconnection
3. Time of day (TOD)/TOU metering
4. Alarm/Event detection, notification and reporting
5. Meter tampering / theft detection
6. Load Control / Load Limiting
7. Pre-paid / Net-metering
8. Energy Accounting & audit
9. Remote firmware upgrade

### **2.1.2 Why Smart Meter is Essential in Bangladesh**

1. Online Vending from anywhere
2. Customer can view meter status from home
3. Utility can update meter firmware and new tariff immediately
4. Scheduled / On-demand Meter data reading at configurable intervals
5. Remote Disconnection / Reconnection
6. Meter temper event immediately displayed on prepaid software
7. Automatic meter monitoring system and hence system loss may be reduced
8. Monitoring the transformer to protect overload
9. Immediate Load management possible
10. Smart meter is essential to go to smart grid

### **2.1.3 Benefits of Smart Meters**

Smart meters provide numerous benefits to users, utility providers for automated meter readings, and overall grid management, load forecasting, and the like.

Each group sees different benefits.

#### **Utility users:**

1. Meter readers and user-supplied data are not required for automated utility meter readings.
2. For more accurate billing, accurate readings can be provided on a regular basis.

#### **Utility provider:**

1. Reduce costs by obtaining readings remotely - no meter readers are required.
2. Readings can be taken on a consistent basis.
3. Usage characteristics can be determined in order to make more precise provisions.

#### **National Provision Planning:**

1. To better understand user requirements, more granular data can be obtained.
2. Better data to enable long-term usage for various user groups - understand time for usage of different groups, trends, and so on.

The installation of smart energy meters has benefited both users and providers by providing more accurate and consistent data, allowing for more accurate billing and the provision of a better service. For users, live data provides a better understanding of usage, which can aid in reducing consumption and providing more ecological / green usage.

### 2.1.4 Architecture of Smart Meter

Smart meters are more efficient, reliable and accurate than traditional electric meters, leading to the replacement of traditional meters with smart meters. Smart meters monitor energy consumption, automatically top up prepaid electricity credits, and provide information to users about the energy consumption of a home or business device.

The smart meter system consists of metering devices connected to the circuit that measures the total power consumption. It has a software application that manages the collected data and serves as a lightweight communication gateway. The portal has a mobile user interface to provide real-time data from the database. Several common communication technologies exist in every meter and can be selected based on data rate, distance, data type and protocol. Data communication and exchange helps quantify demand patterns so utilities and consumers can better forecast their baseline and peak loads, enabling demand management and provisioning issues fast automatic detection and recovery. The lifespan of a smart watch is about 20 years. Architecture of Smart Metering System is shown in the Figure-01.

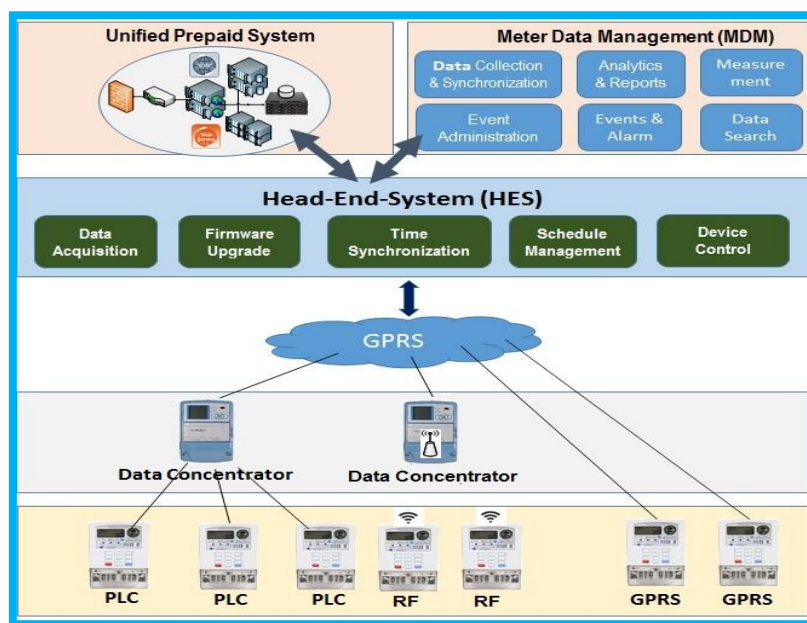

Figure-1: Architecture of Smart Metering System

### 2.1.5 Smart Electricity Meter Design

The smart power meter is embedded in a 32-bit microprocessor deployed on a shared peripheral and memory interface bus, making the system flexible and scalable. Smart meters are optimized for resource management and schedule management reliability. This design facilitates policy planning, inter-process communication, and resource sharing. The counter architecture provides task priority and interrupt handlers, synchronizes concurrent processes and threads, and manages metering and billing, as shown in Fig. 2.



Figure-2: Software architecture of a conventional meter, showing communications with other meter components

Smart meters have two main components: communication and processing. The communication component handles internal communication and information sharing between the meter and the user. The processing element uses an analogue-to-digital converter to convert the voltage and current of the load into a digital representation and stores the data in internal memory.

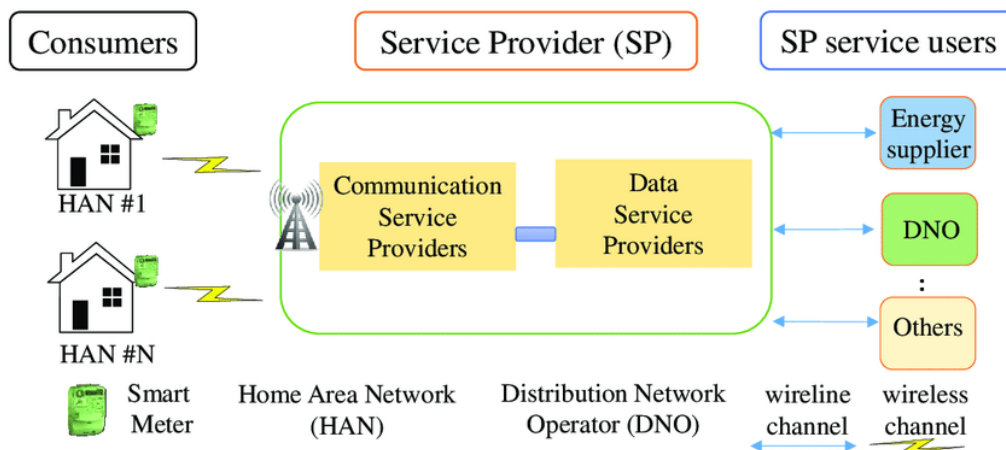

Figure-3: Smart meter working methodology

This data is used to digitally load a form representation and store the data in internal memory. This data is used to calculate power consumption and log fault events. The most common

topologies used in smart meter communication are star, tree, and grid. Figure 3 shows the hardware architecture of silicon and chip based smart power meters. Its main components are shared memory and peripheral bus, metering coprocessor, analog-to-digital converter, and common peripherals.

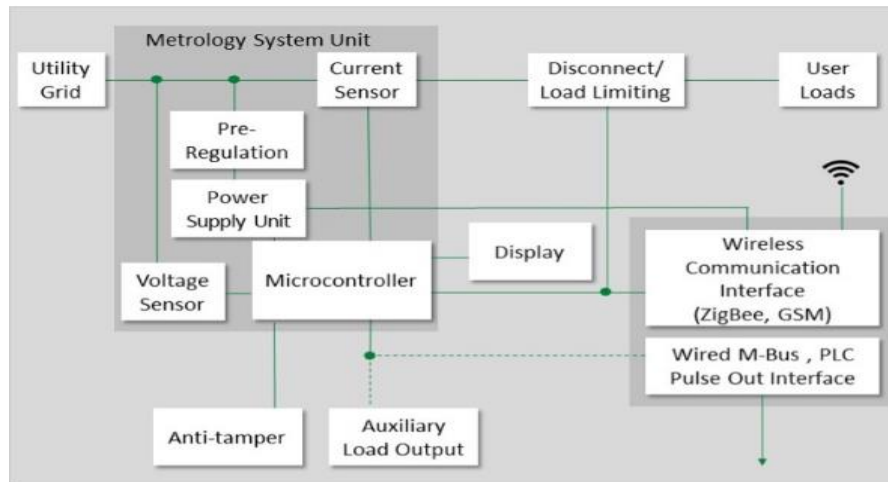

Figure-4: System block diagram of a smart electricity meter showing all the parts of the metering system

As shown in Figure 4, the circuit design has a microcontroller that is programmed to control the entire operation of the system. It reads the input signal as a current and uses the installed software to provide the required output. The output action connects or disconnects loads to/from the grid and turns certain devices on or off. It also instructs the GSM module to send a message to the user when the power is low, when a certain amount of power has been recharged, or when a system failure occurs. This microcontroller can communicate with GSM and LCD module.

### 2.1.6 Smart meter basic block diagram & operation

In terms of functionality, the block diagram of a smart meter contains several elements. A low power supply is also included, with a number of special requirements to ensure the successful operation of the entire smart meter.

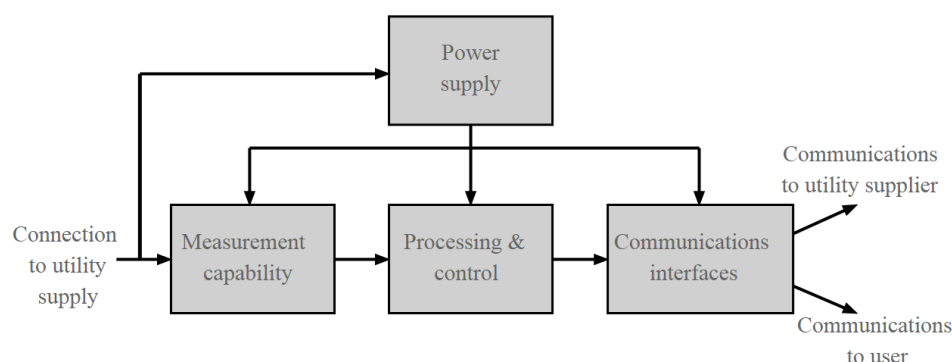

Figure-5: Basic block diagram of a smart energy meter for electricity consumption



As seen in the block diagram, there are several elements to the overall smart meter block diagram that must be considered for the electronic circuit design.

- **Power supply:** This section of the smart meter powers the meter's circuitry as well as providing battery backup and protection against transients, among other things.
- **Measurement capability:** This section of the smart energy meter block diagram addresses the utility's basic measurement. It must be dependable and precise. It will typically output data in digital format, so it will include an analogue to digital converter.
- **Processing:** Any meter of this type will necessitate data manipulation. It must be formatted to be sent over the communications links as well as displayed on the smart meter.
- **Communications:** The smart meter must communicate information back to the utility provider for billing and smart grid management. It must also display information to the user on a smart energy monitor or an In-Home Display, IHD. This can be accomplished using a variety of different communication methods, such as cellular communications, power-line communications, Zigbee and so on.

The various areas of the circuit block diagram have distinct functions and frequently use very different types of electronic circuits.

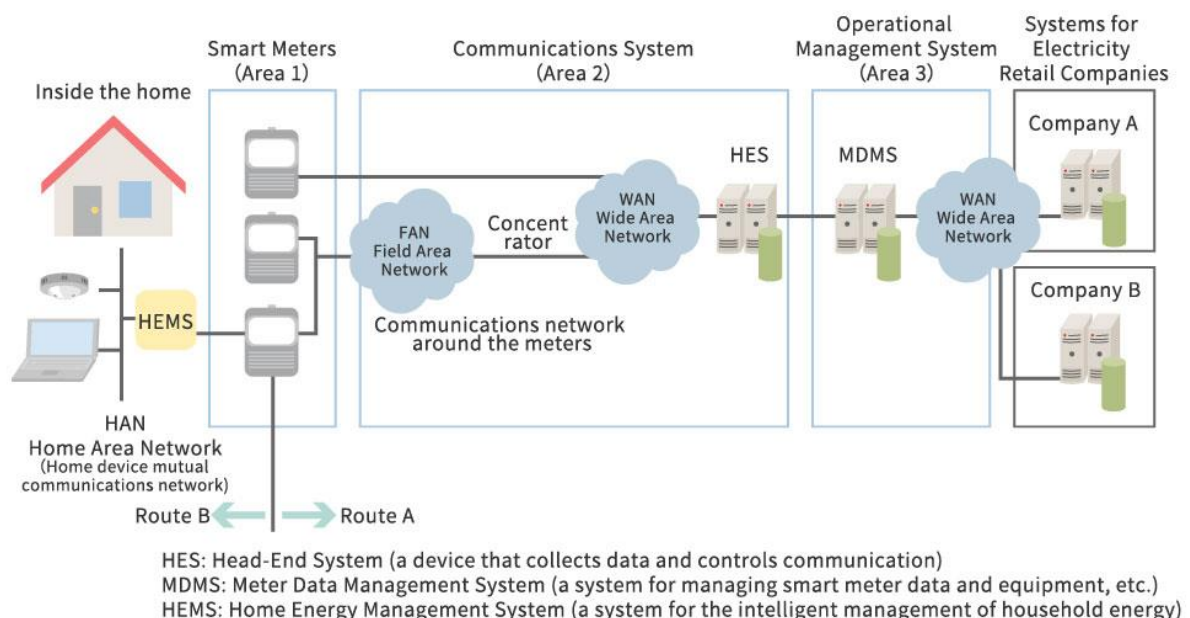

**Figure-6: System diagram showing the information flow during communication**

Every time a meter is connected for the first time, the system checks if the meter is valid and allows the meter to be used for other operations. Every time a meter is connected, the system

continuously checks the power level to determine if it is zero and sends an alert message to the user or owner's phone when the balance reaches the threshold. When the power balance reaches zero, the system will send a warning message and disconnect the meter. The moment the user purchases electricity, the meter is reconnected and goes into a state to monitor the power level to alert the user whenever it reaches a threshold value or zero.

### **2.1.7 Smart Meter Communication Network**

Smart metering is about communication. Let's take a look at the evolution of the different communication technologies used in smartwatches and the different types available.

They are classified according to the transmission medium used, effectively dividing them into wired and wireless technologies. Initially, the two most common technologies for advanced measurement infrastructure were the “traditional” options:

1. Power line or PLC communication (wired)
2. Radio Frequency Mesh or RF Mesh (Wireless)

Now it's time to compare them and understand their pros and cons:

#### **1. Power line communication (PLC)**

PLCs leverage existing powerline facilities in communication efforts. This gives the advantage of using existing expansion infrastructure without the need to lay dedicated cabling. The installation of PLC modules in meters is quite simple, which makes this technology the most popular among smart metering solutions. However, PLCs are not perfect.

#### **2. Radio Frequency Mesh (RF Mesh)**

Unlike PLCs, this technology allows wireless communication and is an essential function of automatic meter reading (AMR). This is mainly used as a means of measuring energy consumption and collecting data from energy consumers. Combined with a PLC, it offers better accuracy and coverage, and like a PLC, it requires modules to be installed on the meter.

**The pros and cons of RF Mesh are:**

#### **PROS:**

- Low-power connectivity allows for low costs and energy-efficient operations;
- Wireless communications unlock advanced smart metering functionality;
- Modules are easy to embed into existing meters.

#### **CONS:**

- Only suitable for restricted ranges with high concentrations of RF modules;

- Signal interference due to devices utilizing the same public frequencies;
- Vulnerable to obstructions such as thick walls or trees.

Due to their differences, integrating PLC as the backbone of the infrastructure and RF Mesh as a technology enabler is a great way to provide a more reliable and accurate experience.

### **2.1.8 Smart meter tariff calculation**

The tariff program is metric. The system will send energy tokens (money) online in encrypted form. A smart meter deducts money from the meter for usage based on the tariff rate. According to the schedule, HES collects energy consumption from meters and sends to MDM. The MDM deducts the used unit money from the customer's deposit. Calculations are based on applicable tariff rates.

### **2.1.9 Commercial Aspects of Smart Metering**

The most significant advantage of smart metering is the granular insight it provides into company's energy consumption and other utility usage. Most smart meters connect directly to an interface, which provides an exact readout of user's usage, broken down by time of day and day of the week or month. Having this information at our fingertips allows users to make better decisions about company's consumption and keeps track of the resource usage. Some interfaces correlate usage with a monetary measurement, such as a watts per hour rating, allowing users to see how much electricity costs them by the minute.

### 2.1.10 Advanced Metering Infrastructure (AMI)

The entire measurement and acquisition system, meters at customer sites, and communication networks between customers and service providers, such as providers, are called AMIs. Smart meters transmit collected data over commonly available fixed networks such as power line communications (PLC), fixed radio frequency (RF) networks, public networks (fixed line, cellular, paging, etc.) Aggregate and send by raters. It is sent to the utility and sent to the meter data management system for data storage, analysis and billing. According to research, Narrowband PLC is the best fit for AMI with over 100 million of his NB-PLC devices installed.

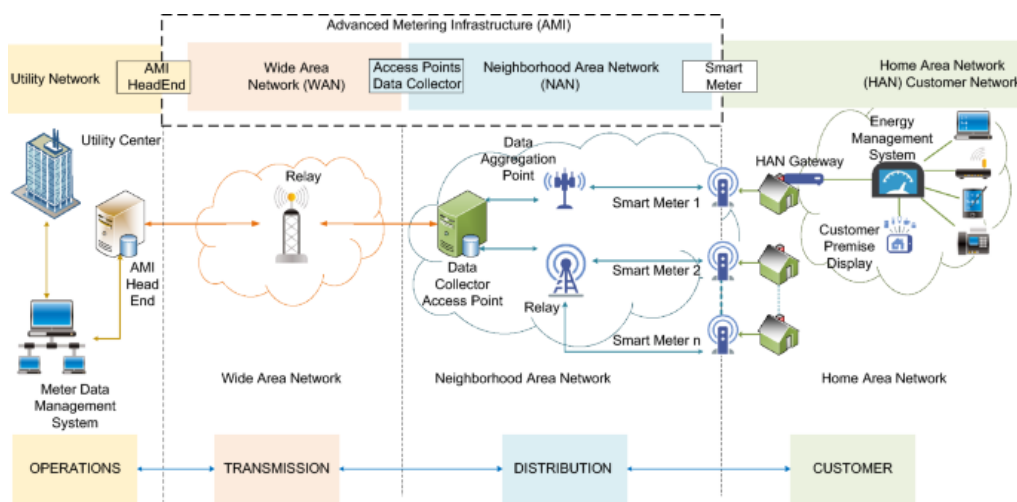

**Figure-7: AMI Infrastructure for Smart Meter**

Utility companies invest billions in AMI systems. In contrast to wireless, PLC solutions for data transmission use existing power cables and do not require new infrastructure. Power line carrier systems have long been popular with many utility companies because they can reliably transmit data through the infrastructure they manage. A utility company can also use public cellular networks to backhaul his AMI data due to its zero footprint, zero implementation costs and low monthly fees. However, in many cases they cannot cover 100% of the entire utility customer base.

## Advanced Metering Infrastructure(AMI)

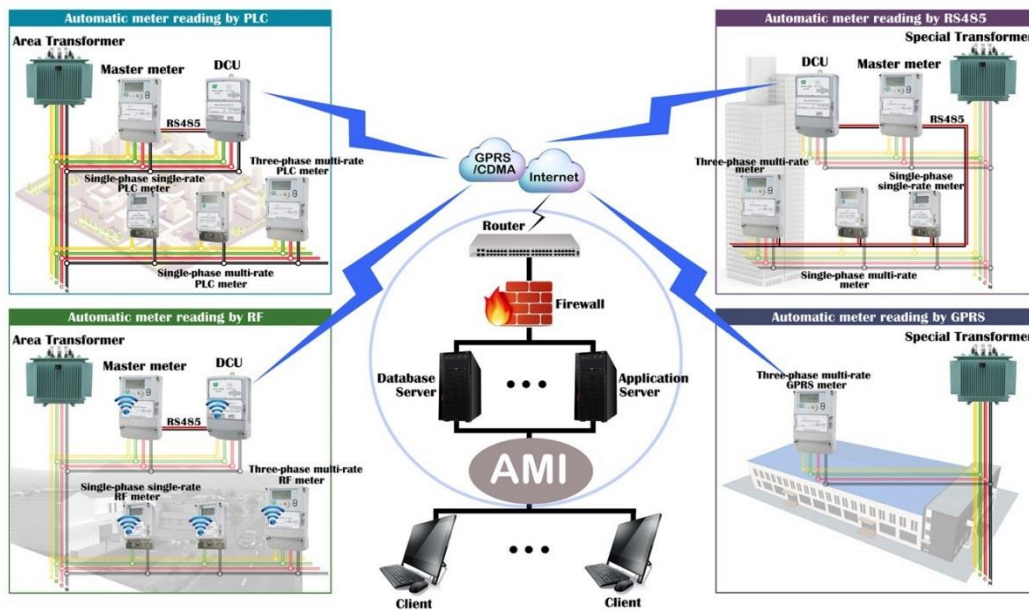

*Figure-8: AMI System Architecture*

Alternatively, this problem is solved by using wireless networks, RF solutions or PLCs for data transmission. Rural utilities and utilities in difficult locations (such as mountainous areas) suffer from poor wireless network coverage and struggle to communicate with consumers. Additionally, wireless and RF solutions suffer from data rate degradation when there is interference such as Bluetooth devices, cordless phones, concrete objects, hills, or even trees. A PLC can communicate with any powerline-connected site and does not require line-of-sight for data transmission. One of the most important considerations is the alleviation of congestion due to the volume of network traffic inherent in smart grid networks. Compared to ZigBee and Wi-Fi based wireless solutions, PLC based AMI has proven to be suitable for avoiding network congestion in emergency situations. Another often-cited requirement is communication channel redundancy. The ubiquity of power lines makes using redundant channels more economical.

Various applications include remote monitoring, outage management (including failure detection of MV equipment), demand response (i.e. managing customer power consumption according to grid supply conditions), island detection (i.e. is not supplied). DG system when there is no power from the grid) and fraud/theft detection.

## Chapter 3: PLC System

### Overview OF PLC System:

Power Line Communications (PLC) transmits data over conductors that are also used to transmit AC power and distribute power to consumers. Also known as Powerline Carrier, Powerline Digital Subscriber Line (PDSL), Mains Communication, Powerline Telecommunications, or Powerline Networking (PLN). Power lines were originally designed to transmit electrical energy in the frequency range of 50-60 Hz. Initially, the initial transmission of data over power lines only served to protect sections of the power distribution system in case of failure. Power line communication was the best way to quickly exchange information between power plants, substations and distribution centers. Included in this logic was the fact that high voltage pylons are among the most robust structures ever built. Protection signals can therefore be transmitted reliably using this signal network. Additionally, many remote locations were not connected to the telephone network. Therefore, it was decided that transmitting signals and exchanging information for grid protection and telemetry purposes over existing power lines would be the best solution. Figure-8 shows the system architecture of the PLC system.

### 3.1 Classification of PLC technology

The bandwidth used is the most distinguishing feature of various PLC technologies. In fact, electromagnetic compatibility (EMC) regulations also classify PLC technology according to this criterion. This will be discussed later in this research. A meaningful classification distinguishes between three PLC technologies:

#### Ultra-Narrowband (UNB):

Refers to systems that use frequencies below 3 kHz, provide a wide operating range, and transmit bit rates around 100 bps. Existing systems use proprietary solutions and have been used in smart meter applications for decades.

#### Narrowband (NB):

Refers to systems operating at frequencies up to 500 kHz. Within this group, we can distinguish between two different technologies:

- Low Data Rate (LDR): Based on single-carrier modulation, several kbit/s can be transmitted. They are traditionally used in smart meter applications and home

automation. Examples of these groups are the IEC 61334-5, which is based on frequency shift keying (FSK) and spread FSK modulation, and the X10 specification.

- **High Data Rate (HDR):** These systems employ multicarrier modulations and attain hundreds of kbit/s. They have been developed in the last decade and seem to be the most cost-effective solution for smart metering applications.

**Broadband (BB):** Also known as BPL (Broadband Power Line), this group includes various systems using the frequency band 5 from 1.6 MHz up to 250 MHz. most They are based on multi-carrier modulation and the latest versions include Multiple Input Multiple Output (MIMO) technology. This technology was developed for high bit rate applications such as small offices and home local area networks. Within smart grids, it is used as a telecom backbone to connect SSs over MV lines, but has also recently been proposed for last mile smart metering applications. Connection from SS to smart meter. NB-PLC is currently the most widely used PLC technology in the last mile part of smart metering networks. Therefore, we will focus our research on this technology in the future.

### 3.2 Architecture of PLC System

Fig. 9 depicts the system model of an NB-PLC-based smart metering network. It consists of the following elements. A management centre, from which smart meters are controlled and where energy consumption values are reported. Interestingly, information retrieved from the smart meters can be also used for other functions such as power quality and outage management, transformer load management and power grid tomography, which integrates with the DSO geographic information system. The management centre is connected to the SS by means of a backbone network. This may consists of a mixture of technologies like DSL, fiber-optics (FO) communications, wireless (radiofrequency) technologies or even BB-PLC, which has proven to be a feasible alternative for this purpose.

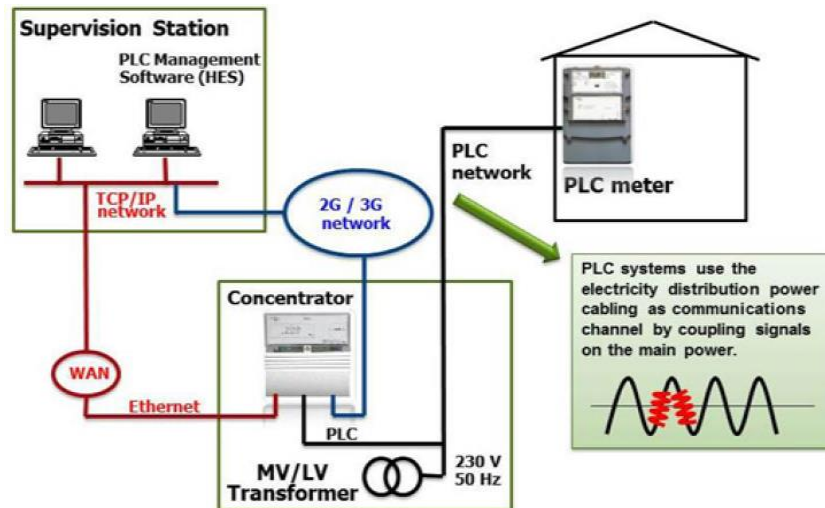

*Figure-9: Architecture of PLC System*

Finally, the last-mile segment of the network connects the smart meters to the data concentrator (DC). The latter may be located at two different places, depending on the number of customers connected to the MV/LV transformer. In scenarios where the number of customers is high, the DC is usually placed at the LV side of the transformer. This is the case of most European urban areas. However, there are countries where the number of customers connected to each transformer is very low, even in urban areas, e.g. in the USA. Since DCs are expensive, placing them in the LV side is not a cost-effective solution. The location of the DC is a key element for the selection of the NB-PLC solution to be employed because many of them are unable to provide connectivity through transformers. As it will be discussed further in this chapter, this is the case of the systems that work in the frequency range below 95 kHz. In these circumstances, even if BB-PLC is used in the backbone network, the connection between the BBPLC device and the NB-PLC one is generally done by means of an Ethernet link, bypassing the transformer as indicated in Fig. 8. An important aspect related to NB-PLC-based systems is the signal injection method. At the customer side, single-phase is generally the only possibility, since homes are usually fed with using a single phase. At the transformer side, while three-phase injection is possible, single-phase injection is currently the most widespread one, i.e. NB-PLC systems do not currently explore the MIMO nature of the network. This contrast to the BB-PLC case, where the latest standardized systems do all include MIMO techniques.



### 3.3 Operating Principle of PLC System

Powerline carriers are not specifically designed for data transmission and provide a harsh environment. Different impedances, loud noise and high frequency dependent attenuation are the main problems. Such complex line networks can have large frequency-dependent magnitude and phase responses. In addition, the channel transfer function itself is time-varying as the network topology changes as network-connected devices are connected or disconnected. Home devices often act as noise sources, affecting the receiver's signal-to-noise ratio. As with any wireless channel, signal propagation between transmitter and receiver does not occur within line of sight. As a result, additional echo should be considered. This echo occurs because there are many propagation paths between the transmitter and receiver. Signal reflections often occur due to various impedance mismatches in the power grid. Each multipath is assigned a specific weighting factor that accounts for return loss and transmission loss. It has been observed that at higher frequencies the attenuation of the channel increases. The channel can therefore be described as random and time-varying with a frequency-dependent signal-to-noise ratio (SNR) across the transmission bandwidth. Figure 10 shows the characteristics of the power line channel.

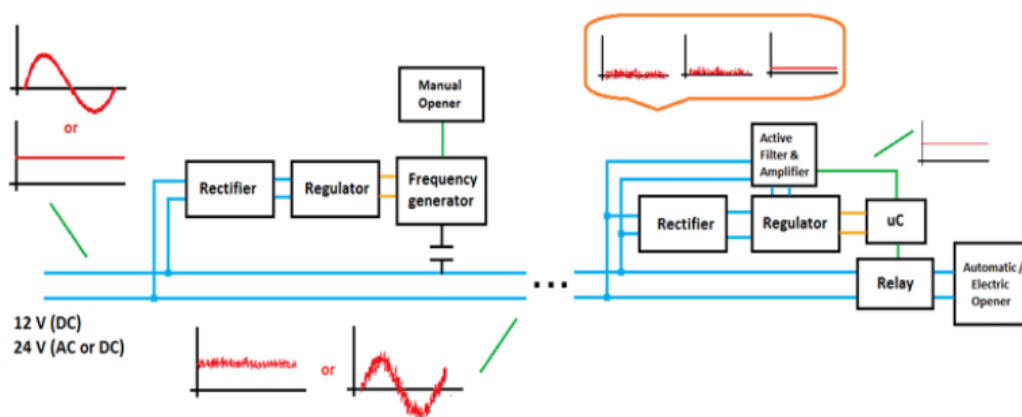

Diagrammatic Representation of the Working Mechanism

Figure-10: Diagrammatic Representations of the Working Mechanism of PLC

### 3.4 Major components of PLC System

1. Wave trap/line trap
2. Coupling capacitor
3. Protective devices
4. Coupling of filter
5. HF cable
6. Lightning arrester
7. Line matching unit

**Line Trap:** The wave trap or a line trap is used to trap the wave frequencies of high magnitude, it would prevent the carrier signal from entering into the substation. The wave trap will be connected to the power line in series, mostly a wave trap consists of a capacitor and inductor to do its operation.



*Figure-11: Line Trap Unit in Substation*

**Coupling capacitor:** This device is used to connect carrier equipment to transmission lines. This device would prevent the power signal from entering the PLC while also allowing the carrier signal to pass through.



*Figure-12: Coupling Capacitor in Substation*

**Lightning arrester:** This device would protect the system from lightning strikes and would be mounted on the structure's highest point. Low resistance cables are used to connect the lightning arrester to the ground, so that if lightning strikes or voltage spikes occur, they will be directed to the ground via the ground wire.



*Figure-13: Lightning arrester*

**Line matching unit:** The line matching unit, which consists of an air-core transformer and some condensers, is used to match the impedance of the lines. This device will be attached to the coupling capacitors' bases. Line matching employs a balancing transformer, a matching transformer, and a capacitor filter to accomplish this.

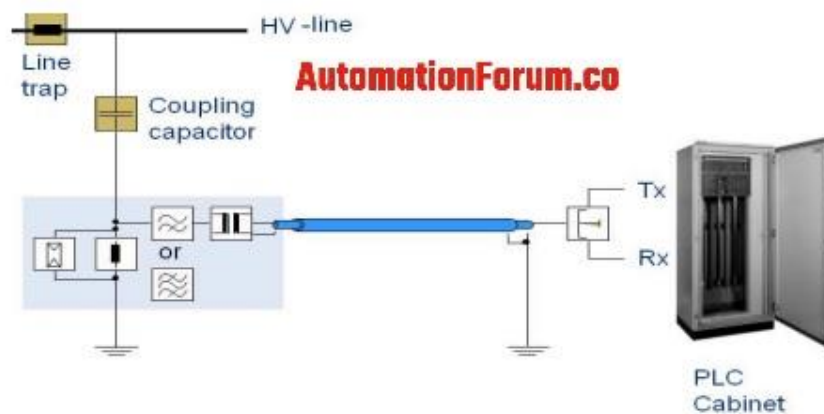

*Figure-14: Line matching unit*

**Earth switch:** This device is used for LMU maintenance, and it grounds the trapped charges. If the LMU or any of its components fails, this switch can be used to ground the LMU.

**HF cables:** These cables are used to carry high-frequency signals between the PLCC station and the LMU.

**Coupling filters:** This device is used to isolate the equipment connection from the power line and to match the power line impedance to that of the HF cable to connected equipment.

**Protective equipment:** In this system, certain protective equipment is used to protect both the carrier equipment and the personnel. A drainage coil, arresters, and a grounding switch are used as protective equipment.

### 3.4.1 Power Line Channel Characteristics

The PLCC channel characteristics are

**Characteristic Impedance:** The transmission line characteristic impedance is given by

$$Z_0 = \sqrt{L/C}$$

Where 'L' is the inductance and 'C' is the capacitance. The unit of the inductance is Henry (H) and the unit of the capacitance is Farad (F). For power line communication it varies from 300 to 800 ohms range.

**Attenuation:** The attenuation is measured in decibels (dB) and the losses of the attenuation occur in the line trap, tuner, and in power lines due to the mismatching impedance, coupling, the restrictive losses, and any other losses.

**Noise:** At the receiving end, the signal to noise ratio (S/N) is high.

**Bandwidth:** The bandwidth range is from 1000 Hz to 1500 Hz for relaying purpose and the bandwidth range from 500 Hz to 600 Hz for FSK (Frequency Shift Keying).

### 3.4.2 Power Line Network Adapters

Some of the best power line network adapters are:

**Actiontec 500:** It is extremely compact in construction and it lacks Gigabit Ethernet support

**Linksys PLEK 500:** It offers relatively low latency and often covers both sockets. It doesn't have a pass-through outlet

**Netgear PLP 1200-100PAS:** It preserves long-range speeds and its power-saving mode causes drops

**Comtrend Bridge:** It is perfect for security camera systems

**Comtrend GCA 6000:** It uses the less popular ghn protocol and it won't work with cable TV or internet

**Zyxel-AV2000:** It is relatively easy to configure and provides good real-world performance

**TP-Link AV1000:** It won't block other outlets and features built-in dual-band Wi-Fi

**TP-Link AV1300:** It is suitable for streaming 4K video

### 3.4.3 PLC Modem

#### PLC Modems/Transceivers

A PLCC system is not complete without a PLC Transceiver. It is the device that transmits and receives data from and from power lines and serves as a hub between power stations and our computers/networking devices. They are connected to the electrical voltage lines in your home or business and operate in two modes: transmit and receive. In transmit mode, they simply receive data from a receiver end on the same network and transmit it. They operate in the opposite direction when in receive mode.

PLC transceivers and other networking devices for PLCC communication are available from a variety of companies. The image below depicts a PLC transceiver.

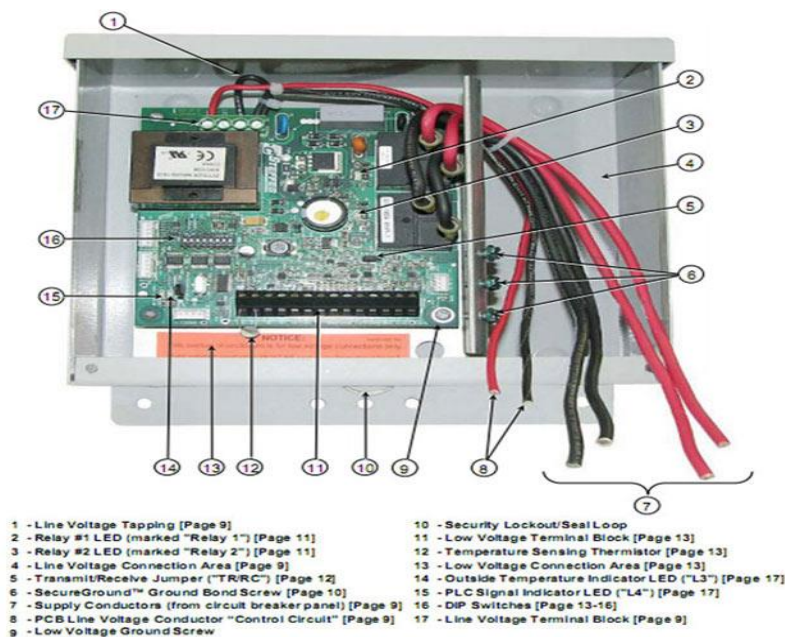

*Figure-15: An Image of PLC Transceiver*

### 3.4.4 Modulation & Superimposition

#### Modulation Techniques

As previously stated, the characteristics of the power line channel change with time and load. As a result, conventional modulation techniques such as ASK, FSK, or PSK cannot be used

with them. PLCC requires a technique to deal with the unpredictability of attenuation and phase shifts. Modulation techniques that use lower frequency ranges of 35 KHz to 95 KHz can outperform those that use the entire available frequency band. The modulation technique used in HomePlug specification network appliances is OFDM (Orthogonal Frequency Division Multiplexing). OFDM modulates information onto multiple carriers, each of which has its own frequency in the range of 4.3 to 20.9 MHz. The incoming bit stream is demultiplexed into  $N$  parallel bit streams, each with a bit rate of  $1/N$  of the original bit rate, and then modulated on  $N$  orthogonal carriers. The modulation technique makes the best use of the available spectrum by employing multiple carriers at the same time. Each frequency is monitored during transmission, and if any interference, noise, or data loss occurs, the responsible frequency is removed. However, this technique does not perform well when there is significant attenuation and jamming in the communication channel, but it can still be very efficient in comparison.

### **3.4.5 Signal Superimposition on Power Lines**

There are two methods for connecting a PLC unit to the power lines: capacitive coupling and inductive coupling. A capacitor is used in capacitive coupling to superimpose the modulated signal on the voltage waveform of the network. Inductive coupling, which uses an inductor to couple the signal with the network's waveform, is another method.

Inductive coupling does not require any physical connection. This makes it safer than capacitive coupling. However, this method has a higher likelihood of signal loss during coupling.

## **3.5 Technical Parameters of PLC System**

### **Important Technical Parameters in PLC Communication**

#### **3.5.1 Noise on Residential Power Circuit (RPC):**

Power line noise is a big problem for data transmission. This is because it rarely shares similar characteristics with the easily analyzed receiver white Gaussian noise that we are so familiar with. Typical sources of noise are brushed motors, fluorescent and halogen lamps, switching power supplies, and dimmer switches. Apart from that, sources of interference, such as amateur radio transmissions, can make certain frequencies unsuitable for communication. Power line noise is either impulsive or frequency selective in nature, or sometimes both. Noise is also location dependent due to high attenuation across power lines. Recent studies have shown that the noise in PLC systems can be classified into four categories.

Here are some methods for reducing noise in power line communication:

- Forward Error Correction (FEC) codes with interleaving can reduce noise in categories.
- To deal with unknown frequencies, frequency hopping with FEC coding can be used.
- Television line frequencies should be avoided when modulating the signal on power lines.

### **3.5.2 Signal to Noise Ratio:**

Signal to Noise Ratio (SNR) is a measurement of quality of the signal. It indicates the amount of the noise in a signal. SNR can be formulated in the following way:

$$SNR = \text{Received Power} / \text{Noise Power}$$

Increasing SNR means increasing the performance of the communication system. By applying noise filters on household appliances, the noise entering into the power system can be reduced. However it will increase the cost of the appliances but is a better solution to improve overall performance.

### **3.5.3 Signal Attenuation:**

Signal attenuation is the reduction in signal strength. Signal attenuation is approximately 100dB/km for low voltage power lines and 10dB/km for high voltage power lines. It necessitates the use of continuous repeaters over a set distance. A variety of factors contribute to signal attenuation, including distance, time, signal frequency, and so on.

## **3.6 Implementation of PLC for Smart Metering and Smart Grid Systems**

The electricity grid is a convenient resource for the transport of communication signals especially if they are applied for electricity grid related services. The integration of the telecommunications transport media in the core of the electricity assets, makes PLC a very attractive option, both in terms of availability and cost. This section includes the electricity grid description, together with key elements of this grid in relation to PLC systems.

### **3.6.1 Grid Description**

The power system consists of four main elements. It consists of Power plants, transmission lines, substations and distribution systems. Power grids are different in different parts of the

world. Networks also vary by country, and their components also depend on the age of the infrastructure. The smart grid finds different instantiations depending on your needs and the segment of the network it references. PLC, in the sense of smart grid in distributed networks, is a telecommunications access technology and is consequently used in the access segment of the power grid. This refers to the so-called MV and LV segments of the network. The MV segment is the part of the grid that transitions from the HV grid to the so-called SS (also called transformer centres, since transformers from MV to LV are located in these facilities). MVs can be classified as above-ground or below-ground, depending on the cable configuration. The power line impedance is different in both types of networks. Cable access is different (signal coupler must be installed differently). LV segment is the part of the network that has direct contact with PoS. The LV segment has two main functions. The first is its capillary action and heterogeneity, as it should be moved everywhere with minimal investment. To understand the variability of this scenario, we must consider the variability of configurations and the number of different components installed over the years. Second, loads (customers and their devices) are connected and disconnected due to the need to provide universal power access, have different power consumption patterns, and different devices are connected and disconnected at different times. Different parts of the electricity grid are connected to each other by a network of subnetworks, each of which may be considered unique in their characteristics and performance. This means that signals and impedances can appear and disappear during the day and the season without any clear and traceable origin.

- **MV segment.** Voltage levels need to be considered in the design of MV PLC solutions. The absolute value of the voltage level is a critical factor to design the couplers that need to transition the telecommunication signals from the transmitters to the receivers through the MV grid.
- **LV segment.** Distances, amount of PoS, and its density in LV grid. These three parameters are presented together, as they are not independent variables. If the distance between transmitters and receivers is too large (in terms of attenuation) for a specific implementation of a technology, or if the density of the PoS is low enough to favor repetition of the PLC signals or if the number of PoS per subnetwork is not high enough to allow for a high enough economic return on investment, PLC might not be an attractive technology.

There are a number of aspects that need to be solved regarding the architecture of the system, and at operational system level. These other aspects are oriented to bridge the gap between the



technology and the devices themselves, and the deployment on the grid. Once PLC systems have been technically proven on field at a massive scale, these aspects will be addressed.

### 3.7 PLCC in Meter Reading

#### How PLCC technology is used in meter reading?

Automatic meter reading using PLC technology is very useful because it saves a lot of time and makes the entire system more efficient. The automatic meter reading system is made up of three parts: the Multifunction Node (MFN), the Concentrator and Communication Node (CCN), and the Operation and Management System (OMS). The figure depicts various components and their interconnections.

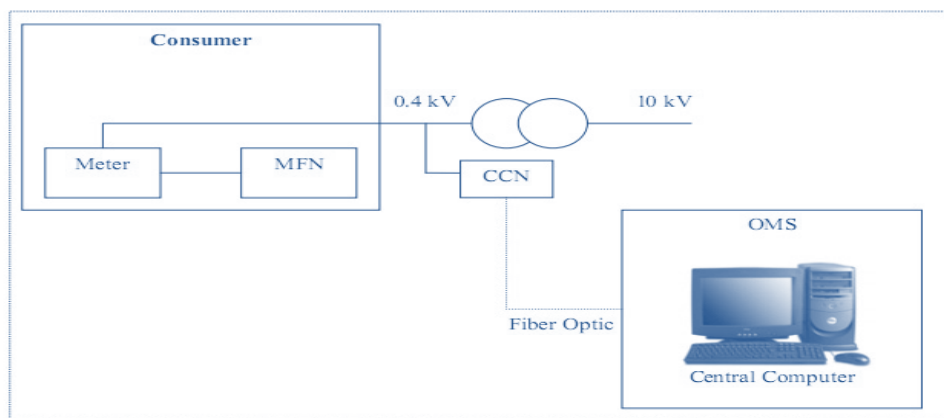

*Figure-16: Automatic Meter Reading System Components and Interconnection between them*

MFN is a unit installed in household meters, either built into the meter or connected to it externally. Its function is to take hourly readings from the meter and store them in a memory chip. CNN is another component that manages all MFNs in a specific area and collects meter readings from all MFNs. It is typically installed on substations and requires the use of a computer. The computer has an Operation and Management System (OMS) installed, which manages all data and meter readings from CNNs.

### 3.8 PLC Performance Assessment

PLC communication networks are very specific due to their limitations. The main limitation is in the network configuration after choosing the architecture. In many telecommunications systems, network planning can be controlled by determining where network equipment is placed. In the case of power grids, the locations where service points and PLC signals must

propagate are fixed, and more importantly, the characteristics of the power grid itself (cable types, specifications, etc.) are generally unknown or to some extent known. PLC behavior is known to be unpredictable. Therefore, when pre-planning is very limited, post-mortem performance assessments are necessary to understand if the results achieved are in line with requirements and where network changes or adjustments are needed. Evaluating the performance of point-to-point connections is easy and has many steps and best practices. This is quite different for shared media technologies, especially NB technologies (control traffic consumes a significant portion of the available bandwidth).

### **3.9 Application of PLC system**

Power line communication is mainly used for communication and remote monitoring between substations. Additionally, it is widely used in technologies such as smart grids, advanced metering infrastructure, and micro inverters. Medium frequency PLCs are used in homes to remotely control lights and appliances without additional wiring. As technology evolves and is presented to a wider audience, it finds more adaptations and applications. It can be used for industrial applications such as traffic light control, irrigation control, machine-to-machine applications such as vending machines, telemetry applications such as offshore oil rigs, and transportation applications such as automotive and train electronics. BPL opens up exciting possibilities for the future and is now used in every smart home or smart room. Even these homes and hotel rooms have various devices that automatically turn them on and off. However, wider usage is not yet common. Access BPL has failed to gain momentum in various countries trying to implement it on a large scale. This outage stems from his BPL's incompatibility with limited range, low bandwidth, traditional broadband usage, routers and modems, and mobile devices. The market for powerline communications is still growing, with the main drivers being low-cost installations that can cover large areas using existing distribution networks, increasing deployment of smart grids, and high demand for broadband over powerline communications.

These are the sectors where power line communication system can be used.

1. Transmission and distribution network
2. Home control and automation
3. Entertainment
4. Telecommunication
5. Security systems

6. Automatic meter reading
7. Telemetry
8. Telephony
9. Protective relaying

### 3.10 Advantages and Disadvantages of PLC System

#### 3.10.1 Advantages

- **Low Implementation Cost:** PLC does not require any installation of new wires which as a result, would significantly reduce the deployment costs.
- **Large Reach:** PLC can enable communication with hard-to-reach nodes where the RF wireless signal suffers from high levels of attenuation like in the underground structures or the buildings with obstructions and metal walls, or simply wherever the wireless signal is undesirable due to the EMI issues in places like hospitals.
- **Lower Running Cost:** PLC provides a low-cost solution compared to the other existing technologies such as RF wireless or visible light communication (VLC) systems.
- **Indoor High Speed:** The implementation of PLC & VLC technologies integrated together has recently received a considerable amount of research attention, which resulted in the enabling of a new generation of high-speed indoor communications for numerous applications.
- Communications possible in challenging environments such as underground installations, metal-shielded cases etc.
- Relatively long technology lifecycle (v/s GPRS)
- Good option for new residential colonies and newly electrified villages with new electrical network designed and built for PLC applications
- Broadband PLC (BPL) can offer telephone and internet connections as well to customers

These advantages lead to more implementations of PLC networks in various industries. But with advantages there also comes some disadvantages.

### 3.10.2 Disadvantages

It also has some disadvantages such as:

- Low transmission speed,
- Sensitivity to disturbance,
- Nonlinear distortion and Cross-modulation between channels,
- Large size and
- The high price of capacitors and inductors used in the PLC system.
- Due to these disadvantages, PLC is still not preferred in some applications.
- Requires good quality power cables with crimped joints (in Bangladesh mostly aluminium wires are have twisted joints which are not good for PLC)
- Requires filters to clean the communication signal (from noise)
- Communication not possible in case of power outage
- Requires trained manpower for O&M.

### 3.11 Limitations of PLC System

Although the prospects for implementation and use of this technology look bright, the concept has several limitations that need to be addressed before commercialization. Power line communication is limited by the existing electrical infrastructure where it is being employed and thus affects powerline channel parameters such as power attenuation, noise, impedance and bandwidth.

- A high SNR ratio is required.
- The power line network is typically unmatched and varies with time and loading. This causes carrier power to be attenuated. This is the most significant disadvantage.
- Reflection losses occur at various points along the carrier frequency's path from transmitter to coaxial cable, line tuner unit, coupling capacitor, and power line to transmitter.
- Power-line communication is not secure.
- The final problem we face is the same one that all new technologies face. Lack of a standard protocol. For this technology to be successful and implemented on a large scale, an organization like the IEEE will need to develop a set of rules or standards for digital data transmission over power lines.

This would allow various equipment manufacturing companies to produce equipment conforming to the standard valid over all countries and the service providers to transmit and receive data as per a fixed protocol.

Once solutions to these limitations are found, this technology can be used for various commercial applications as mentioned in the section above.

### **3.12 Further Scope**

Digital transmission over power lines could enable us to access the internet through any of the millions of power socket in the world. Device to be used to access internet could be simply plugged into the power socket for ready to use "plug and play" Internet access. The biggest application of this concept though could be Internet Access over the Power Lines. Transformers may become the gateway to the warehouse of information-the Internet. This will require us to update the hardware associated with the power lines as well as include routers at transformer sections. Protocols and standards for the same will have to be developed if this technology is to be implemented on a commercial scale. Wi-Fi Hot spots could also be set up close to transformers to provide access to the internet.

## **Chapter 4: Discussion**

### **4.1 Smart Metering:**

#### **4.1.1 The Smart Meter**

The smart meter is an electrometer that measures electricity consumption by time repetition. The merit of these meters is that they send and receive (information / commands) to and from the main center / Command Center. There is a two-way communication facility in the smart meter.

#### **4.1.2 Smart Metering Features:**

1. All smart meters are shut down remotely by the Utility.
2. Any attempt to change plug in needs opening the meter cover.
3. It is recorded in the meter with timestamp.
4. All critical events send immediately to the command center.

#### **4.1.3 Benefits to Utility:**

##### **1. Commercial Benefits:**

- Automated Meter Reading – Improvement in Billing Efficiency
- Remote Disconnection – Improvement in Collection Efficiency
- Improvement in Data Analytics – Improvement in hit rate in Tamper Detection
- Capturing Maximum Demand - Improvement in revenue through SAC & Fixed Charges
- Reduction in Ad-hoc readings - leads to save time & resource
- Faster Detection of Dead Meters - Real Time Energy Audit Reduction in Revenue Billing Cycle Time

##### **2. Operational Benefits:**

- DT Meters on same Canopy leads to identify the Asset Utilization / Overloading etc.
- Removal of Manual Disconnection / Reconnection
- Faster Outage Detection
- Real time Power Quality Monitoring

### 3. Consumer Benefits:

- Less Outages
- Error Free Bills due to no Manual Intervention
- Option to choose – Prepayment
- Better usage visibility through Mobile app
- Enablement for Renewable Integration
- Incentive for maintaining PF>0.85

#### 4.2 Challenges of Smart Metering in Bangladesh

The design challenges to achieve a smart meter are manifold. One of the first challenges is to clearly define functionality. This is because residential and utility smart meters occupy a different range of feature sets with minimal overlap. Clarification of requirements by the user community enables smart meter costs to be optimized by using the best hardware and software components. Some of the features that impact design cost and modularity are:

**a. Communication protocol:** The specific communication protocol to be implemented is specified/prescribed by the smart meter central authority and it is important to prevent proprietary protocols from infiltrating the smart meter.

**b. Communication security:** Communication security in an AMI/Smart Grid environment is a key requirement as remote control functionality is enabled and sensitive sales data is transmitted. It is important that specific sections of the standard (IEC 62351) are specified in the meter firmware compatible with AMI and MDM systems.

**c. Interoperability:** Control commands and other data formats used by smart meters should be interoperable with the existing AMI infrastructure. i.e. counter data:

Different consumers (utilities, industries, and households) require different measurement parameters. Standardizing parameter requirements across consumer segments is a must.

**e. Communication port:** Smart meters are equipped with serial ports and USB, as well as Ethernet and optical Ethernet. Port specifications contribute to case design optimization and upgradeability.

**f. Communication:** Intelligent meters can use a wide range of communication modes including wireless (Zigbee, WiFi, LowPowerRF) and Powerline. Defining a selection of these modes is desirable because it allows targeted research, analysis, and implementation.

**g. Standardization:** Standardizing the size and footprint of smart meters is also an important consideration.

**h. Power quality requirements:** Specifications for the types of power quality measurements required for different consumer segments should be defined for high-order harmonic distortion, dips, swells, dropouts, dips, transient recordings, and recording times. A clear specification of these requirements influences the use of digital signal processors and high-speed memory to implement power quality measurement functions, thus optimizing the cost of smart meters.

Me. User interface standardization options such as touch screen displays and traditional LCD displays.

**i. Time Synchronization:** A specification of how his RTC time is synchronized based on GPS or IRIG-B or from a network should be specified in order to design the internal interfaces and device selection for these functions.

**j. I/O expandability:** Defines the type of I/O function, such as electromechanical relay or solid state, analogue inputs and outputs, and the number of inputs and outputs. This will determine whether the I/O can be accommodated in a smart meter or whether a separate expansion box with the required interface to the meter must be provided.

**k.** Special features such as language support, e-mail SMTP client, FTP, remote firmware upgrade with security features, etc. are better determined early in the design stage to ensure the correct choice of operating system and protocol stack. Your chosen real-time operating system may not support certain client features, so including those features later is not optimal.

#### **4.3 Challenges of PLC Systems for Smart Metering**

Access to large numbers of distributed generators and large scale sensors will exponentially increase the flow of information in the Energy Internet. Therefore, powerline carrier communication is an important technical support for energy Internet access networks, especially in remote mountainous areas and other complex industrial environments where communication networks are not suitable. Power line carrier communication can provide low cost, high speed and flexible communication network coverage. Against the backdrop of the Internet of Energy, new services pose additional challenges for powerline carrier communications. Currently, high-speed, low-voltage broadband powerline carrier communication is mainly used in "local area networks" such as smart homes. The frequency band of high-speed broadband power line carrier communication is mainly concentrated in 3-30MHz, and the available frequency spectrum of the frequency band is not continuous due to various narrowband noises, but the power line carrier communication capacity closely related.



Utilization and bandwidth. Access to large sensors, power distribution terminals, and other devices on the Energy Internet poses significant bandwidth challenges for powerline carrier communications. Powerline carrier communications also face significant challenges when it comes to security and reliability of the energy Internet. On the one hand, it is reflected in reliability. Communication failures have a direct impact on the safe operation of the power grid when it comes to co-processing the production, transmission, consumption and storage of energy in real time. On the other hand, it is also reflected in the security of communication. The open and shared nature of the Energy Internet increases the risk of malicious attacks. Similar to attacks on the Internet, communication failures, loss of user and grid data, and even direct attacks on the grid can tamper with grid data and jeopardize the safe operation of the grid. Research on the application of forward error coding and adaptive modulation and demodulation to carrier communication over power lines can improve communication reliability and bandwidth spectrum utilization efficiency. The use of advanced information technology (ant colony algorithms, genetic algorithms, adaptive control theory, etc.) can improve connectivity capabilities of the power line carrier communication system. This is one of the directions to solve the problem caused by large-scale device access by energy Internet. Advances in semiconductor technology can increase the baseband processing speed of power line carrier communications. Improvements in modulation and coding rates and RF performance significantly improve transmission delays in power line carrier communications. Finally, powerline bearer communication physical layer and application layer data security encryption methods and authenticity protection mechanisms will undoubtedly become an important research topic in energy Internet access network communication technology.

#### **4.4 Commercial Aspects of PLC System**

##### **4.4.1 Overview of the Power Line Communication (PLC) Systems Market:**

The global market for power line communication (PLC) systems is expected to reach around \$14 billion by 2022, growing at an 18.4% CAGR from 2016 to 2022. Power line communications is a relatively new telecommunications technology. It is a communication technology that enables data transfer over existing power cables. Using the power line as a communication medium is also a cost-effective method when compared to other methods because it makes use of existing infrastructure and wires that are available to every household connected to the power line network. PLC implementation, with a focus on Internet access, is being considered in a number of European and Asian countries, as well as in Bangladesh.

The cost-effectiveness of PLC infrastructure in comparison to traditional or competitive technologies is driving the increased adoption of PLC in the residential, commercial, and industrial sectors. As a result of the space efficiency and additional power circulation provided by this technology, the global PLC market is expected to grow moderately in the near future. However, the user's reliance on the same line for power and data increases the centralized risk factor, which could stymie market growth. Proactive government initiatives to promote PLC and smart grids that use PLC are expected to provide the market with lucrative opportunities.

#### **4.4.2 Overview of the Segment**

The global PLC systems market is divided into several segments, including type, solution, component, application, and geography. The type segment is divided into two parts: narrowband PLC and broadband PLC. In terms of revenue, the broadband PLC segment dominated the global market in 2015, and this trend is expected to continue throughout the forecast period, owing to the avoidance of the expense of maintaining a dedicated network of antennas, radios, and routers in a wireless network.

The solution segment is divided into two parts: PLC over AC lines and PLC over DC lines. In terms of revenue, the PLC over AC lines segment dominated the global market and is expected to continue in this direction. However, PLC over DC lines is seeing rapid growth in home networking, lighting, and other applications.

#### **4.4.3 Cost-effectiveness as a result of simplified networking**

Concerns about distribution issues and the additional cost of establishing a data communication network have compelled various organizations to invest in improving the infrastructure of data networking techniques. PLCs are essential in smart grids for controlling power distribution at high voltages and increasing efficiency. It can be used to extend an existing network into new areas without the need for new cables. Because of the region's technological development, the United States currently has the greatest number of grids with smart grid capabilities.

#### **4.4.4 Centralized risk**

PLC enables data transmission and reception by moving a controlled carrier signal over existing power lines. With the introduction of the Internet and new networking technologies such as PLC, interconnection has grown. This increases the likelihood of system failure and security breaches. Network security is becoming increasingly important to personal computer

users, businesses, and the military. However, technological advancements hope to eliminate the impact of this factor in the near future.

#### **4.4.5 Functional areas of PLC beyond AMI**

PLC systems support load control and demand response solutions, as well as capacitor switch bank controllers and transponders, from a functional standpoint. Indeed, demand response systems were among the first solutions available over power lines, even for customers who did not use AMI.

## **Chapter 5 – My Experience at DPDC as an Intern**

### **5.1 About DPDC**

#### **5.1.1 Company**

Dhaka Power Distribution Company Limited (DPDC) is one of the largest power distribution companies in Bangladesh. Dhaka Power Distribution Company Limited (DPDC) was incorporated on 25th October 2005 under the Companies Act, 1994 with an authorized share capital of Tk 10,000 and 100 (100) ordinary shares of Tk 100 each.

It received a business license on October 25, 2005 and began operations on May 14, 2007. On July 1, 2008, the company took over all assets and liabilities of the former DESA and started operations. The number of customers at the time of its founding was 662,553, but now it is 1,195,829. The Board of Directors is the supreme body of overall management of the company within the framework of applicable law. The board consists of her twelve directors appointed by the government.

Led by the Board, DPDC's strategic functions will be driven by a management team led by the Managing Director and her five Executive Directors. H. Executive Director (Technology), Operations; Managing Director (Technology), Engineering; Executive Director (Technology/ICT), ICT & Procurement; Executive Director (Finance) and Executive Director (Administration and Human Resources).

#### **5.1.2 Vision**

To provide high quality and reliable electricity to the people of Dhaka City and Narayanganj area for the desired economic, social and human development of the country.

#### **5.1.3 Mission**

- Providing quality electricity with excellent service.
- Provision of on-demand electricity within the geographic area of DPDC.
- To ensure customer satisfaction.
- Developing new mindsets for all employees in line with company culture.
- Achieve self-sufficiency and profitability by increasing revenues and reducing costs.

#### **5.1.4 Commitment**

- Quality power supplies for every customer.
- Respond quickly to customer needs.
- Initiatives to meet the changing needs of our customers.
- Digitization of distribution systems.

#### **5.1.5 Core Objectives**

##### **For the customers**

Rendering quality services by being innovative in the development of our service quality.

##### **For the owner and shareholders**

Maximizing wealth of the Company.

##### **For the society**

Strengthening the social values by ensuring better services towards consumers and undertaking corporate social responsibility.

##### **For the Nation**

Taking all-out effort to achieve national growth and prosperity.

#### **5.2 Ongoing Projects of DPDC:**

##### **(a) Detailed description of self-financed projects**

Projects completed in the financial year 2021-2022:

01. Project Name: Design, Manufacture, Supply, Installation, Testing & Commissioning of Smart Pre-Payment Meter at NOCS Kamrangirchar on Turnkey Basis.

##### **Ongoing Projects:**

01. Project Name: Design, Manufacture, Supply, Repair, Service, Installation, Testing and Commissioning of Mohammadi 132/33 KV Grid Substation on Turnkey Basis.

02. Project Name: Design, Manufacture, Supply, Installation, Testing & Commissioning of Smart Pre-Payment Meter at NOCS Banglabazar with 03 Years Maintenance Support Service on Turnkey Basis.

##### **(b) Projects included in the Annual Development Program (ADP):**

##### **Projects completed in FY 2021-2022:**

01. Project Name: Construction of New 132/33 KV & 33/11 KV Substation under DPDC.

##### **Ongoing Projects:**

01. Project Name: Pre-payment Metering Project for 06 NOCS under DPDC.

02. Project Name: Expansion and Strengthening of Power Distribution System in DPDC Areas.
03. Project Name: Power Distribution System Development Project in DPDC Areas.
04. Name of the Project: Installation of eight lakh and fifty thousand smart pre-payment meters in the area under DPDC.
05. Project Name: Underground substation construction project at Karwanbazar, Dhaka under DPDC.
06. Project Name: Construction and Rehabilitation of Substations, Installation of Capacitor Banks in Power System and Introduction of Smart Grid System in DPDC Areas.

### **5.3 Completed Projects of DPDC:**

1. Implementation of a 50kwp grid tied solar project on the rooftop of Bangladesh secretariat building/s on boo (build own operate)

- Total capacity: 50kwp
- Project location: secretariat building
- Implementing agency: Rahimafrooz Renewable Energy Ltd.
- Cod: 31.12.2014
- Present status: in operation

2. Implementation 200kwp grid tied solar power plant on the rooftop of Sheikh Russel roller skating complex

- Total capacity: 200kwp
- Project location: Sheikh Russel roller skating complex
- Implementing agency: Bangladesh roller skating federation
- Cod: 15.12.2017
- Present status: in operation

3. Installation of 20kwp solar charging station

- Total capacity: 20kwp
- Project location: Siddirgonj, Narayangonj
- Implementing agency: DPDC
- Cod: 28.05.2018
- Present status: in operation

### **The following topics are highlighted in the internship program:**

(a) Introduction of electricity supply, gradual formation of PDB, REB, DESA, DESCO and DPDC by the Government under the Power Sector Reforms 1

(b) Power supply system at DPDC.

(c) Network Operations and Customer Service (NOCS) activities at DPDC.

(d) Activities of supporting offices of NOCS (eg: HR, Finance, ICT, Audit, Planning, Development, Metering, System Protection, Grid, Tariff and Energy Audit).

(e) Activities of Training and Development Department of DPDC.

(f) Inspection of 132/33 KD GIS Substation and 33/11 KV Substation.

(g) Inspection of SCADA System, Workshop, Meter Testing Lab, Central Warehouse, Medical Center of DPDC.

#### **5.4. Visiting Sites:**

##### **SCADA (Supervisory Control and Data Acquisition):**

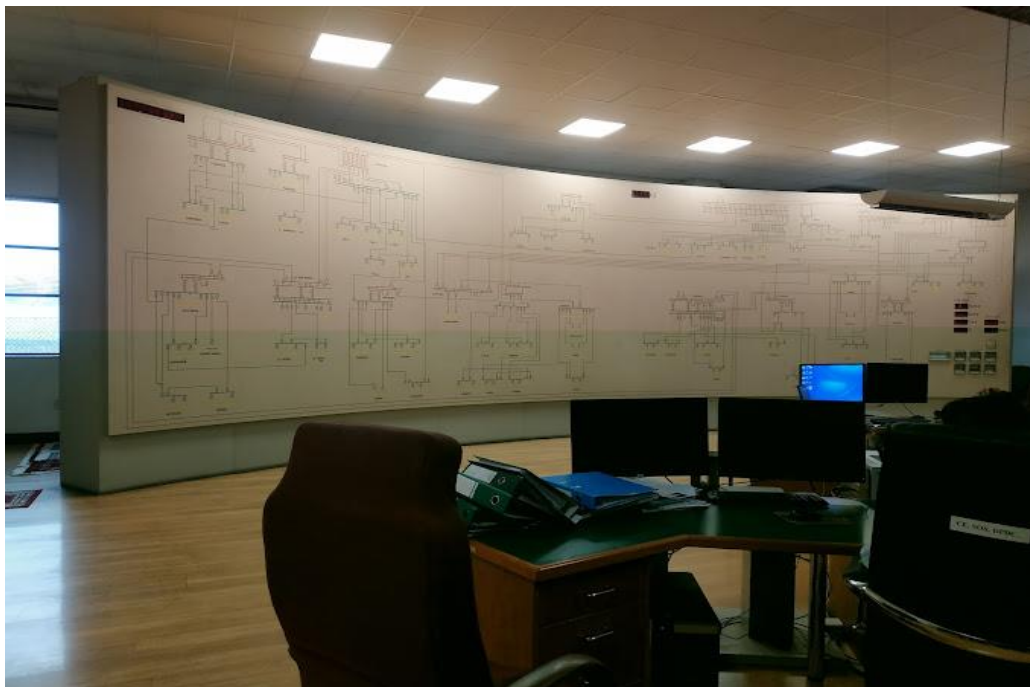

*Figure-17: SCADA Visit*

**Dhanmondi Sub-Station:**



*Figure-18: Dhanmondi Substation Visit*

**Grid North-2:**



*Figure-19: Grid North-2 Visit*



**Biddut Bhaban, BPDB:**



*Figure-20: Biddut Bhaban, BPDB, Dhaka*

**5.5 Real Life Data and Scenario of PLC System under DPDC:**

METER_NO	CUSTOMER_NO	NAME	ADDRESS	SANCTIONED_LOAD (KW)	TARIFF	NOCS
020110004876	22686805	MR. M.A AKNDA	1304 - DHANIA		2 LT-A	Matuail
020110091032	35703981	SAHIDUL ISLAM	1305,DHONIA,KADAMTOLI		2 LT-A	Matuail
Monthly Data for December 2022						
Month End Reading (KWH)	Month End Balance (TK)	Consumed Unit (KWH)	Monthly amount of money spent(TK)	MD (KW)	MD occurring time	
4594.3100	259.65	156.87	782.54	0.7310	2022-12-14 13:30:00	
6415.4300	394.07	161.95	811.60	0.4160	2022-12-04 19:00:00	

*Figure-21: Data of PLC implementation under DPDC*

## **Chapter 6: Conclusion & Future Prospects**

### **6.1. Conclusion**

This intern paper has discussed the strategic facets of PLC system applications over the power grid for smart metering. In order to understand how PLC systems might fit in the Smart Metering networks, the history, strong points, and limitations of PLC systems have been demonstrated. The paper's justification is that these PLC systems' design and architecture must be further developed in the field in order for them to provide the functionality and performance required for the Smart Grid. These implementation guidelines discussed in the paper will manage to obtain the performance results needed.

This intern paper also includes our experience as an intern at DPDC. We also talked about smart metering at DPDC, ongoing projects at DPDC, and so on.

The paper concludes with the challenges that PLC systems face as they evolve to meet the needs of Smart Grid networks. On the one hand, the need for further optimization of the existing PLC system is emphasized. On the other hand, the interaction between PLC systems and the grid is shown to be a factor that must be used both to improve PLC system performance and to gain a better understanding of the grid itself. Finally, the combination of PLC and non-PLC technologies is proposed as a possibility for paving the way to Smart Grids.

## 6.2 Future Prospects

Power Line Communication (PLC) is the best solution for many AMI requirements and is frequently preferred over RF, depending on the circumstances. PLC meets all of the essential AMI system requirements, and with advances in concurrent feeder/phase communication, it now delivers exceptional network throughput improvements. PLC systems, for example, are ideal for utilities operating widely dispersed networks (e.g., a low density of end points per square mile) because the required investment in communication infrastructure is minimal. To collect and transmit information from end points, PLC only requires communication equipment in the substation. There is no need for additional network infrastructure because all communications are carried over existing power lines. We can get to a meter or device anywhere an electric signal goes, even if it's more than 100 miles away. Furthermore, R&D investments in technologies and add-on solutions that use PLC data to deliver an ever-expanding array of new capabilities continue.

For dealing with urban-rural cases, the key is to understand meter densities. The meter-dense area may be a city, but it may also be a growing subdivision with a much higher density than the majority of a service territory. The challenge in a hybrid system is obviously not to duplicate infrastructure. The utility must distinguish between substations with more geographically dispersed assets and those with a higher meter density, and then apply the most appropriate solution to each group of substations. By combining PLC and RF, hybrid solutions could offer customers significantly lower total cost of ownership. This necessitates a review of the structure in terms of substations, including which areas are more urban. Data about substation configurations required for applying the best combination of solutions can be developed through close collaboration with the customer.

Because of its unique capabilities, PLC is specifically suited to a segment of the power distribution market where it is the ideal, best-in-class solution.

Our primary concern for electrical utilities is to reduce peak power consumption and shift it to low load hours. A communication system that connects consumers and electric utilities is likely to be especially useful in areas such as metering and peak load reduction. As technology advances, the PLC network seen in this study simplifies and reduces living expenses. We must continue to look for a better solution, ideally one that can be applied to a wide range of business scenarios. While researching technical possibilities, we will need to create business scenarios for commercial purposes. We look forward to receiving support from the appropriate authorities for our new vision of Digital Bangladesh.

## References

- [1] [A. Cataliotti, V. Cosentino, D. D. Cara, G. Tine, "Simulation of a power line communication system in medium and low voltage distribution networks", in Proc. IEEE AMPS Int. Workshop Appl. Meas. Power Syst., Aachen, Germany, 2011, pp. 107–111. DOI: 10.1109/AMPS.2011.6090429.](#)
- [2] [A. Mathur, M. R. Bhatnagar, B. K. Panigrahi, "Performance evaluation of PLC under the combined effect of background and impulsive noises", IEEE in Communications Letters, vol. 19, no. 7, pp. 1117–1120, 2015. DOI: 10.1109/LCOMM.2015.2429129.](#)
- [3] [Ahmed, M. O. & Lampe, L., 2013. Power Line Communications for Low Voltage Power Grid Tomography. IEEE Transactions on Communications, 61\(12\), pp. 5163-5175.](#)
- [4] [Berganza, I. et al., 2016. PLC for Smart Grid. In: L. Lampe, A. M. Tonello & T. G. Swart, eds. Power Line Communications: Principles, Standards and Applications from Multimedia to Smart Grid. Chichester: Wiley, pp. 509-561.](#)
- [5] [Berganza, I. et al., 2011. PRIME on-field deployment. Udine \(Italy\), Proceedings of the IEEE International Conference on Smart Grid Communications.](#)
- [6] [https://en.wikipedia.org/wiki/Power-line\\_communication](https://en.wikipedia.org/wiki/Power-line_communication)
- [7] [https://www.researchgate.net/publication/224161848\\_Application\\_of\\_Power\\_Line\\_Communication\\_for\\_Data\\_Transmission\\_Over\\_PWM\\_Network](https://www.researchgate.net/publication/224161848_Application_of_Power_Line_Communication_for_Data_Transmission_Over_PWM_Network)
- [8] [https://www.researchgate.net/publication/327389488\\_Smart\\_Metering\\_Systems\\_Based\\_on\\_Power\\_Line\\_Communications](https://www.researchgate.net/publication/327389488_Smart_Metering_Systems_Based_on_Power_Line_Communications)
- [9] <https://dpdc.gov.bd/site/page/816191d7-0196-4e00-aa59-4e3cf6a400a4/->
- [10] [https://en.wikipedia.org/wiki/Dhaka\\_Power\\_Distribution\\_Company](https://en.wikipedia.org/wiki/Dhaka_Power_Distribution_Company)
- [11] <https://dpdc.gov.bd/site/page/00beca42-bc18-4bb9-960e-a5ad8132815a/->
- [12] <https://www.eetimes.com/power-line-communications-for-smart-meter-networks/>