



INTERNSHIP REPORT

ON

POWER GENERATION, TRANSMISSION, DISTRIBUTION AND
PROTECTION SYSTEM EQUIPMENTS OF SIDDHIRGANJ 2×120 MW PEAKING
POWER PLANT

By

MD. SHAMIUL ISLAM (2010-3-80-001)

MITHUN SARKAR (2010-3-80-011)

ABDULLAH AL ASIF (2010-3-80-029)

Submitted to the

Department of Electrical and Electronic Engineering

Faculty of Sciences and Engineering

East West University

In partial fulfillment of the requirements for the degree of
Bachelor of Science in Electrical and Electronic Engineering
(B.Sc. in EEE)

Spring, 2015

INTERNSHIP REPORT

ON

POWER GENERATION, TRANSMISSION, DISTRIBUTION AND
PROTECTION SYSTEM EQUIPMENTS OF SIDDHIRGANJ 2×120 MW PEAKING
POWER PLANT

By

MD. SHAMIUL ISLAM (2010-3-80-001)

MITHUN SARKAR (2010-3-80-011)

ABDULLAH AL ASIF (2010-3-80-029)

Submitted to the

Department of Electrical and Electronic Engineering

Faculty of Sciences and Engineering

East West University

In partial fulfillment of the requirements for the degree of
Bachelor of Science in Electrical and Electronic Engineering
(B.Sc. in EEE)

Spring, 2015

Approved By

Intern Advisor
Dr. Khairul Alam
Associate Professor

Department Chairperson
Dr. Halima Begum
Assistant Professor

Approval Letter



ELECTRICITY GENERATION COMPANY OF BANGLADESH LIMITED

(An Enterprise of Bangladesh Power Development Board)
Siddhirganj 2x120 MW Peaking Power Plant, Siddhirganj, Narayanganj
Tel: 880-2-7692013, Fax: 880-2-7691280, E-mail: pd2x120@egcb.com.bd

Office of the
Chief Engineer

Date: 21.09.2014

TO WHOM IT MAY CONCERN

This is to certify that **Md. Shamiul Islam** son of Md. Sirajul Islam, **Roll no.** 2010-3-80-001; Department of Electrical & Electronic Engineering, East West University have successfully completed Industrial Training at **Siddhirganj 2x120 MW Peaking Power Plant** of Electricity Generation Company of Bangladesh Ltd from **23.08.2014 to 06.09.2014, 13.09.2014 & 20.09.2014**. During his training period he was familiarized with operation and maintenance of GE Frame 9E Gas Turbine, Gas Booster Compressor, Instrument Air Compressor, Water Treatment Plant, Switch –Gear, Transformer, Sub-station, etc.

He is young, dynamic, sincere and able to take responsibility.

We wish him every success in life.

Aminul
21.09.14

Md. Aminul Haque Khan
Executive Engineer (Operation)
Siddhirganj 2x120 MW Peaking Power Plant
EGCB Ltd, Siddhirganj, Narayanganj.



ELECTRICITY GENERATION COMPANY OF BANGLADESH LIMITED

(An Enterprise of Bangladesh Power Development Board)
Siddhirganj 2x120 MW Peaking Power Plant, Siddhirganj, Narayanganj
Tel: 880-2-7692013, Fax: 880-2-7691280, E-mail: pd2x120@egcb.com.bd

Office of the
Chief Engineer

Date: 21.09.2014

TO WHOM IT MAY CONCERN

This is to certify that **Mithun Sarkar** son of Mihir Sarkar, **Roll no. 2010-3-80-011;** Department of Electrical & Electronic Engineering, East West University have successfully completed Industrial Training at **Siddhirganj 2x120 MW Peaking Power Plant** of Electricity Generation Company of Bangladesh Ltd from **23.08.2014 to 06.09.2014, 13.09.2014 & 20.09.2014**. During his training period he was familiarized with operation and maintenance of GE Frame 9E Gas Turbine, Gas Booster Compressor, Instrument Air Compressor, Water Treatment Plant, Switch –Gear, Transformer, Sub-station, etc.

He is young, dynamic, sincere and able to take responsibility.

We wish him every success in life.

Aminul
21.09.14

Md. Aminul Haque Khan
Executive Engineer (Operation)
Siddhirganj 2x120 MW Peaking Power Plant
EGCB Ltd, Siddhirganj, Narayanganj



ELECTRICITY GENERATION COMPANY OF BANGLADESH LIMITED

(An Enterprise of Bangladesh Power Development Board)
Siddhirganj 2x120 MW Peaking Power Plant, Siddhirganj, Narayanganj
Tel: 880-2-7692013, Fax: 880-2-7691280, E-mail: pd2x120@egcb.com.bd

Office of the
Chief Engineer

Date: 21.09.2014

TO WHOM IT MAY CONCERN

This is to certify that **Abdullah Al Asif** son of Md. Mustafizur Rahman, **Roll no.** 2010-3-80-029; Department of Electrical & Electronic Engineering, East West University have successfully completed Industrial Training at **Siddhirganj 2x120 MW Peaking Power Plant** of Electricity Generation Company of Bangladesh Ltd from **23.08.2014 to 06.09.2014, 13.09.2014 & 20.09.2014**. During his training period he was familiarized with operation and maintenance of GE Frame 9E Gas Turbine, Gas Booster Compressor, Instrument Air Compressor, Water Treatment Plant, Switch –Gear, Transformer, Sub-station, etc.

He is young, dynamic, sincere and able to take responsibility.

We wish him every success in life.

Aminul
21.09.14

Md. Aminul Haque Khan
Executive Engineer (Operation)
Siddhirganj 2x120 MW Peaking Power Plant
EGCB Ltd, Siddhirganj, Narayanganj.

Authorization Letter

We declare that we are the sole authors of this internship report. We authorize East West University to make any part of this report be reproduced, stored in a retrieval system or transmitted in any form by any means, electronic, mechanical, photocopying, recording or otherwise for the purpose of industrial attachment.

Md. Shamiul Islam

Mithun Sarkar

Abdullah Al Asif

Acknowledgment

First and foremost, we wish to convey our heartfelt gratitude to Almighty Allah for His help to complete the internship successfully. We want thank the authority of Siddhirganj 2×120 MW Peaking Power Plant for providing us such opportunity to accomplish the industrial training.

We also want to thank all those people who helped to complete our internship successfully. In this process our special thanks go to Engr. Md. Abu Sayeed (Sub-Divisional Engineer-Electrical), Engr. Md. Masud Alam (Sub-Divisional Engineer –Instrumentation & Control (I&C)), Engr. Alip Sarder (Sub Assistant Engineer-Mechanical) and Engr. Md. Golum Mortuza Khan (Sub-Divisional Engineer-Operation) who coordinated our internship program and helped us to get acquainted with other engineers. They helped us to learn the scheduled topics which were presented during our internship training.

We would like to thanks and gratitude to our supervisor Dr. Khairul Alam, Associate Professor, Department of Electrical & Electronic Engineering, East West University for giving his valuable time for us to complete this report successfully. We would also like to mention the name of Dr. Halima Begum, Chairperson, Assistant Professor of the Department of Electrical & Electronic Engineering, East West University. We are grateful to all our teachers for their cooperation and encouragement throughout our whole academic life at East West University.

Executive Summary

We did our internship at Siddhirganj 2×120 MW Peaking Power Plant located at Siddhirganj, Narayanganj on the bank of the river Shitalakkha from 23th August to 20th September 2014 and this internship report is the result of those 15 days attachment. Our duration of internship period was divided into four sections: generation, instrumentation and control (I&C), mechanical and electrical. During our internship period we gathered practical experiences over the topics related to power generation, switchgear protection and power distribution which we have learned inside the class room or from books. In this report we have focused on the processes which are used in Siddhirganj 2×120 MW Peaking Power Plant.

For power generation, natural gas is used in Siddhirganj 2×120 MW Peaking Power Plant. With the help of the plant engineers we observed the control room, protective equipments such as relays, circuit breakers. We acquired knowledge about various types of transformers, isolators, circuit breakers, lightning arresters, current transformers, potential transformers and other equipments of the power station, the details of which are described in the text.

Training Schedule

The internship started on 23.08.2014 and ended on 20.09.2014. The training schedule is given below:

Day	Duration	Division	Trainer
Saturday 23.08.2014	9 AM to 5 PM	Control Unit	Engr. Md. Masud Alam Sub-Divisional Engineer(I&C)
Sunday 24.08.2014	9 AM to 5 PM	Electrical	Engr. Md. Abu Sayeed Sub-Divisional Engineer(Electrical)
Monday 25.08.2014	9 AM to 5 PM	Mechanical	Engr. Alip Sarder Sub Assistant Engineer(Mechanical)
Tuesday 26.08.2014	9 AM to 5 PM	Mechanical	Engr. Alip Sarder Sub Assistant Engineer(Mechanical)
Wednesday 27.08.2014	9 AM to 5 PM	Mechanical	Engr. Alip Sarder Sub Assistant Engineer(Mechanical)
Thursday 28.08.2014	9 AM to 5 PM	Electrical	Engr. Md. Abu Sayeed Sub-Divisional Engineer(Electrical)
Saturday 30.08.2014	9 AM to 5 PM	Control Unit	Engr. Md. Masud Alam Sub-Divisional Engineer(I&C)
Sunday 31.08.2014	9 AM to 5 PM	Electrical	Engr. Abu Sayeed Sub-Divisional Engineer(Electrical)
Monday 01.09.2014	9 AM to 5 PM	Electrical	Engr. Abu Sayeed Sub-Divisional Engineer(Electrical)
Tuesday 02.09.2014	9 AM to 5 PM	Electrical	Engr. Abu Sayeed Sub-Divisional Engineer(Electrical)
Wednesday 03.09.2014	9 AM to 5 PM	Electrical	Engr. Abu Sayeed Sub-Divisional Engineer(Electrical)
Thursday 04.09.2014	9 AM to 5 PM	Electrical	Engr. Abu Sayeed Sub-Divisional Engineer(Electrical)
Saturday 06.09.2014	9 AM to 5 PM	Electrical	Engr. Abu Sayeed Sub-Divisional Engineer(Electrical)
Saturday 13.09.2014	9 AM to 5 PM	Operation	Engr. Md. Golum Mortuza Khan Sub-Divisional Engineer(Operation)
Saturday 20.09.2014	9 AM to 5 PM	Fire Fighting	Engr. Md. Golum Mortuza Khan Sub-Divisional Engineer(Operation)

Table of Contents

Approval Letter	2
Authorization Letter	5
Acknowledgment	6
Executive Summary	7
Training Schedule	8
Chapter 1: Introduction	16
1.1 Objective of the Internship.....	16
1.2 Company Profile.....	16
1.2.1 Mission and Vision.....	17
1.2.2 Strategies and objective	17
Chapter 2: Generation System of the power plant	19
2.1 Introduction	19
2.2 Gas Booster Compressor (GBC)	19
2.2.1 Gas filtration.....	19
2.2.2 Compression system.....	20
2.3 Combustion chambers.....	21
2.3.1 Spark Plugs	21
2.3.2 Ultraviolet flame detectors	22
2.3.3 Fuel nozzles	22
2.3.4 Crossfire tubes	22
2.4 Generator	22
2.4.1 Generator Cooling System.....	24
2.5 Gas Turbine	24
2.5.1 Combustion.....	24

Undergraduate Internship Report

2.5.2 Rotor.....	25
2.5.3 Stator	25
2.6 Water Treatment Plant	25
2.7 Plant Air and Instrument Air	26
2.8 Excitation system.....	26
2.9 Lubricating oil system.....	26
2.9.1 Lubricating Oil Pumps	27
2.9.2 Midst eliminator.....	28
2.10 Gas Valve Modules.....	28
2.10.1 Stop Ratio Valve	28
2.10.2 Gas control valve.....	29
2.10.3 Servo valve	29
Chapter 3: Substation	30
3.1 Transformer	30
3.1.1 Power Transformers	30
3.1.2 Instrument transformer	33
3.2 AC and DC Auxiliary System.....	34
3.2.1 AC Auxiliary System	34
3.2.2 DC Auxiliary System	35
3.3 Isolators.....	35
3.4 Insulators.....	35
3.5 Underground Cables	35
3.6 Bus Bars	36
3.7 Single line diagram.....	36
Chapter 4: Testing and Maintenance System	37
4.1 Transformer Maintenance and Oil Test	37
4.1.1 Routine Analysis	37

Undergraduate Internship Report

4.1.2 Water Content Test.....	37
4.1.3 Acidity Test.....	37
4.1.4 Dielectric Strength and Resistivity Test.....	38
4.1.5 Dissolved Gas Analysis.....	38
4.1.6 Furan Analysis.....	38
4.1.7 Polychlorinated Biphenyl Test.....	39
4.1.8 Fibers in Oil Test.....	39
4.1.9 Power Factor Test.....	39
4.1.10 Breathing process.....	39
4.2 Maintenance Process of Instrument Air or Plant Air Compressor.....	39
4.3 Alternator Maintenance.....	40
4.3.1 Winding Insulation.....	40
4.3.2 Bearing Connection.....	40
Chapter 5: Switchgear and Protection System.....	41
5.1 Generator Protection.....	41
5.1.1 Over-Current Protection.....	41
5.1.2 Over-Voltage Protection.....	41
5.1.3 Over and under frequency Protection.....	41
5.1.4 Rotor Earth Fault Protection.....	42
5.1.5 Under Excitation (Loss of field) Protection.....	42
5.1.6 Current Unbalance Protection.....	42
5.1.7 Transmission Line Protection.....	42
5.1.8 Distance Relay.....	42
5.2 Transformer Protection.....	42
5.2.1 Differential Protection.....	43
5.2.2 Over-Current Protection.....	43
5.2.3 Buchholz Relay.....	43

5.3 Lightning Arrester	43
5.4 Circuit Breaker	43
5.4.1 Air Circuit Breaker.....	44
5.4.2 SF ₆ Circuit Breaker	44
5.4.3 Vacuum circuit breaker	45
5.4.4 Miniature Circuit Breaker and Molded Case Circuit Breaker	46
Chapter 6: Control system and instrumentation	47
6.1 Main Control Room.....	47
6.1.1 Max-DNA control system	47
6.1.2 GE Mark VI Control System	48
6.2 Local Computer based Automatic Control Room.....	48
6.2.1 Water Feeding and Drum Level Control.....	48
6.2.2 Air and Gas Control System.....	49
6.2.3 Lube Oil Control System.....	49
6.2.4 Compressor Starting.....	49
6.2.5 Alarm System.....	49
6.3 Manual Control system.....	50
6.4 Controlling Valves	50
6.5 Pressure Gauge and Mechanical Speed Checking.....	51
6.6 Flame Detector	51
6.7 Air Flow Transmitter	51
6.8 Automatic Voltage Regulator (AVR).....	51
Chapter 7: Operating Process of the Power Plant.....	52
7.1 Introduction	52
7.2 Operating Modes	52
7.2.1 Primary mode.....	52
7.2.2 Lean-Lean Mode	52

7.2.3 Premix steady state mode	52
Chapter 8: Mechanical workshop	54
8.1 Overhead crane	54
8.2 Portable mobile crane	54
8.3 Lathe machine	54
8.4 Milling machine.....	54
8.5 Radial drill.....	54
8.6 Arc welding machine	55
Chapter 9: Backup and Protection system.....	56
9.1 DC auxiliary system.....	56
9.1.1 Auxiliary DC power supply	56
9.1.2 Emergency Diesel Generator (EDG).....	56
9.2 N ₂ plant	57
9.3 Firefighting system	57
Chapter 10: Conclusion	59
10.1 Discussion	59
10.2 Problems.....	59
10.3 Recommendations.....	60
Appendix	61
References.....	62
Daily Activity Report	63

LIST OF FIGURES

Figure 2.1: Gas filter system.....	19
Figure 2.2: Motor, gear box and centrifugal compressor of GBC.....	20
Figure 2.3: Water treatment plant	26
Figure 2.4: Lubricating oil system	27
Figure 2.5: Midst eliminator.....	28
Figure 3.1: Generation transformer.....	31
Figure 3.2: Medium voltage unit auxiliary transformer.....	32
Figure 3.3: Unit auxiliary transformer	33
Figure 3.4: Single line diagram.....	36
Figure 4.1: Oil testing machine-Megger OTs100F.....	38
Figure 5.1: Air circuit breaker	44
Figure 5.2: SF ₆ circuit breaker.....	45
Figure 5.3: Vacuum circuit breaker	46
Figure 6.1: Main control room.....	47
Figure 6.2: GE Mark VI control system.....	48
Figure 6.3: One side view of manual control room.....	50
Figure 9.1: Auxiliary DC power supply.....	56
Figure 9.2: N ₂ plant	57
Figure 9.3: CO ₂ cylinder	58

LIST OF TABLES

Table 1.1: Details of Siddhirganj 2×120 MW Peaking Power Plant	16
Table 2.1: Ratings of motor.....	20
Table 2.2: Ratings of gear box.....	21
Table 2.3: Ratings of centrifugal compressor.....	21
Table 2.4: Ratings of generator.....	23
Table 3.1: Readings of power transformer	30
Table 3.2: Readings of medium volt unit auxiliary transformer	32
Table 3.3: Readings of station auxiliary transformer.....	33
Table 5.1: Ratings of SF ₆ circuit breaker	45
Table 5.2: Ratings of vacuum circuit breaker.....	46

Chapter 1: Introduction

1.1 Objective of the Internship

The objective of this internship is to get introduced practically with the power generation and transmission process which give us an idea that how the generator, motor, turbine etc works. We also get little bit idea about the management system of the company. By observing the power station we know the working process of the power station and it helps to relate it with our theoretical knowledge.

1.2 Company Profile

The Construction of Siddhirganj 2×120 MW peaking power plant project has been completed on the bank of the river Shitalakhya within the Siddhirganj power premises funded by Asian Development Bank. Electricity Generation Company of Bangladesh Limited (EGCB) signed a contract with Bharat Heavy Electricals Limited (BHEL) as EPC contractor for the above project on 31 January, 2007. First Unit was put on test run on 20 November, 2009 and it was inaugurated by the Honorable Prime Minister on 14 February, 2010. The second Unit was put on test run on 26 May, 2010. The second Unit was taken over from the EPC (Engineering Procurement Construction) contractor on October 14, 2010. COD (Commercial operation Date) of both units was efficient from February 5, 2012[1].

Table 1.1: Details of Siddhirganj 2×120 MW Peaking Power Plant [1]

Item	Particulars
Contractor	Bharat Heavy Electricals Limited (BHEL), India
Site	Siddhirganj, Narayanganj
Mode of financing	GOB and ADB
No. of unit	2
Capacity	211.76 MW (2 x 105.88 MW)
Fuel	Natural gas
Contract signed	31 st January, 2007
Contract effective date	16 th June, 2007
Inaugurated (Unit - 1)	14 th February, 2010
Commercial operation date	5 th February, 2012

1.2.1 Mission and Vision

Mission of EGCB Ltd is to excel in electricity business by generating efficient, reliable and cost effective electricity in an environmentally responsible manner to satisfy their customers.

Vision of EGCB Ltd is “Generation of quality Electricity for the Betterment of the Nation”.

1.2.2 Strategies and objective

Strategies:

- i. Maintaining suitable organizational system to make it functional to cater to the present and future need and to develop a well-knit management team.
- ii. Ensuring proper staffing as per the organ gram with appropriate job description for every position. In the process to develop human resources continuously.
- iii. Designing and implementing appropriate reward and incentive schemes to motivate employees and ensure their commitment to the organization.
- iv. Delegating adequate financial and administrative authority matching with responsibility to the respective officials/executives at different levels.
- v. Allocating appropriate resources and logistic support depending on the requirement.
- vi. Undertaking need-based training programs and human resources development initiatives for the officers and staff of EGCB.
- vii. Introducing modern management approach and an organizational culture for continuous improvement.
- viii. Ensuring proper coordination and cooperation amongst different sections/ departments within EGCB.
- ix. Different organizational procedures (operation, maintenance, inventory & procurement, personnel etc.) to be developed, standardized and implemented for improving organizational effectiveness.
- x. Support of the Govt., Donor etc. to be utilized to take up new projects for generation of electricity.
- xi. Becoming cost effective by undertaking different measures for cost reduction and efficient fund management.
- xii. Generate surplus income to invest in growth of the company. In the process to enhance capacity of the plant by replacing old machines and increase generation capacity by adding modern machines.

Objective:

During project implementation phase:

- i. To ensure timely construction and commissioning of Siddhirganj 2×120 MW peaking power plant.
- ii. To ensure timely construction and commissioning of Siddhirganj 450 MW combined cycle power plant (Erstwhile 2×150 MW peaking power plant).
- iii. To ensure timely construction and commissioning of Haripur 360 MW Combined Cycle Power Plant.

Long Term Objectives:

- i. To ensure uninterrupted power generation.
- ii. To increase efficiency of man and machine.
- iii. To recruit skilled and experienced manpower.
- iv. To implement corporate culture in the organization.
- v. To strengthen financial position of the company by earning maximum profit through offering best services to our valued customer.

Chapter 2: Generation System of the power plant

2.1 Introduction

In this chapter we discuss about the generation and the operation process of the different sector (GBC, GT etc) of the power plant to produce power.

2.2 Gas Booster Compressor (GBC)

GBC is one of the major parts of the whole generation process of the power plant. Gas compressor system is used to increase the fuel gas pressure for the gas turbine, which includes, gas inlet filter/separator, compressor, gear box, electric motor, recirculation pipes and cooling agent, lubrication oil/sealing oil system, inlet and outlet pipes and necessary instruments and system monitoring control and the composition of the operational system. The compressor supplies fuel gas to the gas turbine with the absolute pressure of 21.73kg/cm^2 . The normal gas outlet temperature is 130.5°C . The flow rate is 8692.3kg/h . The compressor is forced-lubrication. The flow of the lubrication oil is 3.79 g/min with a gauge pressure of 1.4kg/cm^2 [4].

2.2.1 Gas filtration

Gas comes from Titas Gas and passes through the filtration system. Supplied gas by Titas has many impurities. It removes the impurities such as pipe scale, iron sulfide, hydrates, water, liquid hydrocarbons, sulfur products and carbon dioxide to ensure the quality. After filtering the gas it will send to the compressor of the GBC.



Figure 2.1: Gas filter system [2]

2.2.2 Compression system

The filtered gas goes into the compressor of GBC. Compressor has three parts,

- i. Motor
- ii. Gear box
- iii. Centrifugal Compressor

Motor is used to start up the whole compression system. After starting the motor its speed goes to 1492 rpm. A gear has connected with the motor. Gear box is used to increase the speed and the speed goes to 1485 rpm.



(a) Motor

(b) Gear box

(c) Centrifugal compressor

Figure 2.2: Motor, gear box and centrifugal compressor of GBC [2]

Ratings of Motor, Gear box and Centrifugal compressor:

Motor:

Table 2.1: Ratings of motor [3]

KW	2020
Stator voltage	6600
Stator ampere	209
Speed	1492 rpm
Frequency	50Hz
AMB. Temp	60°C
Weight	9760 kg

Gear box:**Table 2.2: Ratings of gear box [3]**

Rated power	2222kw
I/O speed	1485/11366
Lube oil recommended	ISO-VG-46
Lube oil quantity	60LPM

Centrifugal compressor:**Table 2.3: Ratings of centrifugal compressor [3]**

Model	BCL406
Normal capacity	33086Nm ³ /h
Suction pressure	10.73kg/cm ²
Delivering pressure	26.85kg/cm ²
Power	1562kw
Normal speed	11396 rpm
Max continuous speed	11396 rpm
Temperature	150°C

2.3 Combustion chambers

Combustion chamber is essential part of GT to produce electricity. The main purpose of this combustion chamber is to create fire which helps to rotate the turbine blade. For firing we use gas but also use air which supply to sufficient oxygen for firing. To get fresh air we use inlet guide vent (IGV) that is used to remove unnecessary and unwanted particles. If we do not use IGV, then life time of the turbine blade will be reduced.

2.3.1 Spark Plugs

Combustion is initiated by means of the discharge from two high voltages, retractable electrode spark-plugs installed in adjacent combustion chambers. These spring -injected and pressure retracted plugs receive their energy from ignition transformers. At the time of firing, a spark at one or both of these plugs ignites the combustion gases in the chamber, the gases

the remaining chambers are ignited by cross-fire through the tubes that interconnect the reaction zones of remaining chambers. As rotor speed increases, chambers pressure causes the spark plugs to retract and the electrodes are removed from the combustion zones [4].

2.3.2 Ultraviolet flame detectors

During the starting sequence, it is essential that an indication of the absence of flame to be transmitted to control system. For this reason, a flame monitoring is used consisting of four sensors are installed on tow adjustment combustion chambers and electronic amplifier is mounted in the turbine control panel. The ultraviolet flame sensor consists of flame sensor, containing a gas filled detector. The Gas within this flame sensor detector is sensitive to the presence of ultraviolet radiation is emitted by a hydrocarbon flame. DC voltage is supplied by amplifier that is impressed across the detector terminals. If flame is present, then the ionization of gas in the detector allows conduction in the circuit activates the electronics to give an output defining flame. The four flame detectors are located in the combustion chamber No 4 , 5 , 10 , 11 out of total 14 combustion chambers [4].

2.3.3 Fuel nozzles

Each combustion chamber has equipped with a fuel nozzle that emits a metered amount of fuel into the combustion liner. Gases fuel is admitted directly into each chamber through metering holes located at the outer edge of the swirl plate. When liquid fuel is used, it is atomized in the nozzle swirl chamber by high pressure air. The atomized fuel/air mixture is then sprayed into the combustion zone. Action of the swirl tip imparts a swirl to the combustion air with the result of more complete combustion and essentially smoke free operation of the unit [4].

2.3.4 Crossfire tubes

The 14 combustion chambers are interconnected by means of cross fire tubes. These crossfire tubes propagate the flame to other combustion chambers.

2.4 Generator

A generator is a one kind of device which converts the mechanical energy to electrical energy. There are two types of generators at EGCB that are manufactured by BHEL, India.

Undergraduate Internship Report

The components of a generator are given below:

- i. Frame,
- ii. Stator
- iii. Stator winding,
- iv. Rotor,
- v. Rotor windings,
- vi. Generator Auxiliary Compartment
- vii. Air filters,
- viii. Bearings etc.

When a dc current is applied to the rotor winding for synchronous generator, then a rotor magnetic field is created. Here prime mover is used to turn the rotor which is produced rotating magnetic field. To provide dc field current brushless exciters are used at EGCB power plant. DC field is controlled by an Automatic Voltage Regulator (AVR).

Generator ratings:

Table 2.4: Ratings of generator [3]

Model	TARI 1080-36p
Manufacturer	BHEL, India
Drive	Gas Turbine
Output power	108.6 MW
Apparent power	135.75 MVA
Power factor(P.F.)	0.80
R.P.M	3000
Phase	3
Stator voltage	11 KV
Stator current	7125 A
Rotor voltage	370 V
Rotor current	817 A

2.4.1 Generator Cooling System

While the generator is running then generator is heated up. But excessive heat is not allowed in generator and it reduces the performance and lifetime of the generator. In EGCB there are two types of cooling system. One is air cooling and other is water cooling system.

i. Air cooling

Air cooling process is used to cool down the generator. When the air is passed through the generator then it dissipates the heat energy. Air around the generator is very hot and we replace the hot air by passing cool air in the generator. Finally the temperature falls down.

ii. Water cooling

Water cooling process is used to cool down the generator. Cooling fins are bounded by the generator to absorb the heat and it carries the heat away. Water is flowing continuously by a motor and then the heat is dissipated.

2.5 Gas Turbine

Gas turbine is one of the major parts of the power station from where power is generated. In EGCB power plant there are two GT.

2.5.1 Combustion

The compressor on a gas turbine takes the air around at normal pressures and compresses it to much higher pressures and temperatures. The number of compressor stages is seventeen (17). There are two types of Compressor,

- i. Axial flow
- ii. Heavy duty

Combustion section:

- i. Reverse flow type
- ii. 14 combustion chamber
- iii. Fuel nozzle
- iv. Spark plug and ignition system flame detectors and also cross fire tubes

2.5.2 Rotor

The compressor rotor is an assembly of 15 individual wheels, 2 stub shafts, through bolts, and compressor rotor blades. The air is used to cool: 1. 1st and 2nd stage buckets 2. 2nd stage aft & 3rd stage forward rotor wheel space 3. Also maintains turbine rotor at Compressor Discharge Temperature (355°C) 4. 1st stage wheel space is cooled by air passes through high pressure packing seal at aft end of compressor rotor.

Stages 5, 6, 7 & 8 compressor rotor blades are coated with specialized material to avoid corrosion due to moisture formation at this region [4].

Main Components of rotor

- i. Nozzle or Diaphragm.
- ii. Blades or Buckets.
- iii. Shrouds.

2.5.3 Stator

The stator of compressor is mainly consists of Four major sections

- i. Inlet Casing
- ii. Forward Compressor Casing
- iii. After compressor Casing
- iv. Compressor discharge casing.

These sections, in conjunction with the turbine shell and exhaust frame form the primary structure of Gas Turbine. The stator blade for stage 1 through 4 is mounted by similar dovetails into ring segments. The ring segments are inserted into circumferential grooves in casing and are held in place with locking keys. In stages 5 through 17, the stator blades and exit guide vanes are inserted directly into circumferential grooves in casing [4].

2.6 Water Treatment Plant

Water treatment plant is essential for the plant. Water is used to cooling in this plant. Actually the mineralized water is not directly used in the plant because it full of different minerals, anions and cat-ions. If we use mineralize water, it reacts with the metal. In water

treatment plant, the water takes from the Shitalakhya River. At starting anions and cations are removed and changes the water into de-mineralized by the process of reverse osmosis and this process is used to clean water.



Figure 2.3: Water treatment plant [2]

2.7 Plant Air and Instrument Air

An air compressor is used to produce instrument air, plant air, and nitrogen. Carbon molecular sieve (CMS) is used to absorb the carbon related material. Oxygen is also absorbed by CMS. Instrument air is used in different types of pneumatic valve and in journal bearing. Lube (lubricating) oil is used for the operation of journal bearing. As it is a mechanical contact, it cannot be 100% leakage free. So the lube oil can leak out from the bearing. To stop the leaking, instrument air is used as a filling to pressurize the lube oil. This filling is used only at GBC. Since lube oil and instrument air can react with each other, nitrogen is used as a barrier to hinder the reaction. Nitrogen is also used inside different pipes when the operation at the plant remains turned off for a long time. This is used to stop the corrosion of the pipe.

2.8 Excitation system

By firing in combustion chamber blade is started to rotate. When the speed goes to 3000rpm then the excitation is started by rotation of rotor in generation unit of GT.

2.9 Lubricating oil system

Lubricating oil system is a process which is used to cool down the heat of the mechanical equipment of the power station. When we start the power plant, then the heat is produced inside the mechanical equipments. This heat can damage the mechanical equipments. For this reason lubricating oil system is essential for power station.



Figure 2.4: Lubricating oil system [2]

2.9.1 Lubricating Oil Pumps

Lubrication to the bearing header is supplied by three lube pumps:

- i. The main lube supply pump is a positive displacement type pump mounted in and driven by the accessory gear.
- ii. The auxiliary lube supply pump is a submerged centrifugal pump driven by an A.C motor.
- iii. The emergency lube supply pump is a submerged centrifugal pump driven by a D.C motor.

i. Main Lube Pump

The main lube pump is built into the inboard wall of the lower half casing of the accessory gear. A splined quill shaft drives it from the lower drive gear. The output pressure to the lubrication system is limited by a back-pressure valve to maintain system pressure.

ii. Auxiliary Lube Oil Pump

The auxiliary lube pump is a submerged centrifugal type pump driven by an A.C. motor. It provides lubricant pressure during start-up and shut-down of the gas turbine when the main pump cannot supply sufficient pressure for safe operation.

iii. Emergency Lube Oil Pump

The emergency lube pump is a D.C., motor-driven pump, of the submerged centrifugal type. This pump supplies lube oil to the main bearing header during an emergency shutdown in the event the auxiliary pump has been forced out of service because of loss of A.C. power, or for other reasons.

2.9.2 Midst eliminator

Function of Midst Eliminator is to remove moisture/oil-fume of lube-oil. It is a part of lubricating oil system of GT. A lot of filters are used in this process act as separator.



Figure 2.5: Midst eliminator [2]

2.10 Gas Valve Modules

There is a gas valve unit in front of the combustion chamber of this power plant. There are different types of valves which are given below:

2.10.1 Stop Ratio Valve

The main purpose of the Stop Ratio Valve (SRV) is used as gas stop valve. When generator changes its operation mode, then we need to control the flow of gas. For this purpose SRV is used to control the flow of gas. Another purpose is to regulate the fuel pressure of the Gas

Control Valve (GCV). SRV can also increase flow of gas. For this reason it is also called Speed Ratio Valve.

2.10.2 Gas control valve

The main purpose of Gas Control Valve (GCV) is used for safety of gas turbine. It can control the pressure of gas which is used in combustor. If we don't control the pressure of gas, than we can run the turbine properly. We need sufficient amount of gas pressure to run the turbine. For this reason GCV is used.

2.10.3 Servo valve

Servo valve is used to control the flow of fuel, compressor bleed valves, combustor bypass and the position of inlet guide vane. It is important for turbine performance and safety purpose of operation mode.

Chapter 3: Substation

Substation is use to change the characteristics of voltage (AC to DC), frequency and power factor of the supply of electricity. It deals with voltage and current by the requirement of the plant. In EGCB power plant there is used power transformers and Instrument transformers. In this substation there are used auxiliary systems like AC and DC, underground cables, bus bar, insulator, isolator etc.

3.1 Transformer

A transformer is an electrical device that transfers energy between two or more circuits through electromagnetic induction [9]. Electromagnetic induction is the production of an electromotive force across a conductor [10].

There are two types of transformer. They are:

- i. Power transformer
- ii. Instrument transformer

3.1.1 Power Transformers

Power transformer is used to step up or step down voltage according to accomplish the desired condition.

Table 3.1: Readings of power transformer [3]

Manufactured by	Jhansi, BHEL India, 170 MVA
Voltage	11/132 KV (step up)
Line Current	HV side: 743.55 A LV side: 8922.68 A
Type of cooling	Oil forced air forced (OFAF)
Temperature rise in oil	50 ⁰ C (maximum)
Temperature rise in winding	55 ⁰ C
Weight of the oil	54120 kg
Oil quantity	60800 liter

In power station there is used many transformers for various purpose. That is,

- i. Generation transformer (GT).
- ii. Medium volt unit auxiliary transformer (MVUAT).
- iii. Unit auxiliary transformer (UAT).
- iv. Station auxiliary transformer (SAT).

i. Generation transformer (GT)

Power transformer does both step up and step down operation of the requirement of the station. When voltage is supplied by the station, the Power transformer is use to step up the voltage. The generating voltage of this station for one GT is 11kv. It will step up the voltage to 132kv to supply it to the grid. At the off time of a GT it will have to need power from the grid to run its auxiliary component. That time power transformer will step down the voltage that is 132/11kv. There are two GT in this power station.

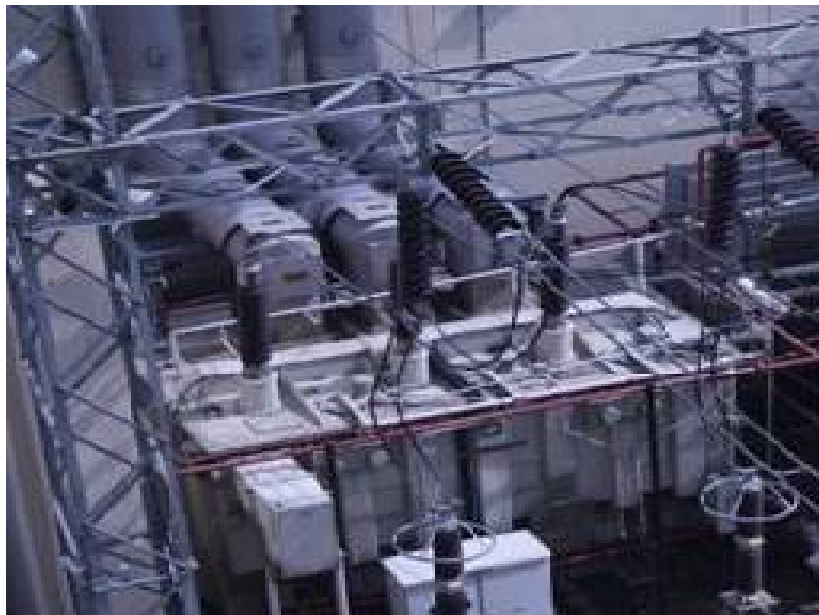

Figure 3.1: Generation transformer [2]

ii. Medium volt unit auxiliary transformer (MVUAT)

This is used to step down the voltage from 11kv to 6.6kv. To start up the starting motor 6.6kv is required which is supplied from here. Gas booster compressor (GBC) also requires 6.6kv which is supplied from here. The maximum temperature of this transformer is 53°C. Line

current in high voltage (HV) side is 5A. No load voltage in HV side is 11kv and LV side is 6.6kv. There are two MVUAT in this power station.

Table 3.2: Readings of medium volt unit auxiliary transformer [3]

Manufactured by	Jhansi, BHEL India, 12.5 MVA
Voltage	11/6.6 KV (step down)
Type of cooling	Oil natural air forced (ONAF)
Line current	HV Side: 656.08 A LV Side: 1045.92 A



Figure 3.2: Medium voltage unit auxiliary transformer [2]

iii. Unit auxiliary transformer (UAT)

In a station many fan, light, Computer, AC etc. runs, which required low voltage compare to GBC or starting motor. It is needed to step down the voltage, because a power station deals with high voltage. UAT step down the voltage to 400V. Its HV side has 6.6kv and LV side have 400V. Gas turbine motor control circuit (GTMCC) also requires 400V. So GT related motors supplied voltage is provided by here. There are two UAT in this power station.



Figure 3.3: Unit auxiliary transformer [2]

iv. Station auxiliary transformer (SAT)

SAT has the similarity with UAT. SAT step down the voltage to 400V. Its HV side has 6.6kv and LV side have 400V. It is used to charge the station switch board (SSB). There are two SAT in this power station.

Table 3.3: Readings of station auxiliary transformer [3]

Manufacturer	Jhansi, BHEL India, 2.5 MVA
Voltage	6.6/0.440 KV (step down)
Type of cooling	Oil natural air natural (ONAN)
Line current	HV side: 218.6 A LV side: 3436.6 A

3.1.2 Instrument transformer

In a substation there is a flow of high voltage and current. It is difficult to measure those high current and voltage. To measure the high voltage and current instrument transformers are being used.

There are two types of instrument transformers. They are:

- i. Current Transformer (CT)
- ii. Potential Transformer (PT)

i. Current Transformer (CT)

A current transformer has used where the voltage in circuit is high. It steps down the high current to a low current which can be measurable. Its secondary side is connected to an ammeter of very small capacity but its scale is calibrated according to actual values. The ratio of maximum load current and required current of the current transformer is 800:1 for 132 KV transmission line.

ii. Potential Transformer (PT)

A potential transformer is a step down transformer. It has a large number of primary turns and a small number of secondary turns. In this power plant Potential Transformer ratio is 1200:1 for 132 KV transmission lines that mean potential transformer converts the 132 KV voltages into 110 voltages. PT is connected in parallel with the transmission line.

3.2 AC and DC Auxiliary System

When AC power supply fails then it is used to power up the power plant equipment's and also provide backup.

There are two types of auxiliary system. They are:

1. AC auxiliary system
2. DC auxiliary system.

3.2.1 AC Auxiliary System

AC auxiliary system is used to operate the internal equipment's within the power plant. There are two types of AC auxiliary system in EGCB. They are:

- I. Unit auxiliary system
- ii. Station auxiliary system.

3.2.1.1 Unit Auxiliary System

Unit Auxiliary System is needed to start the AC generator. Here to start this auxiliary system a step down transformer is connected to the high voltage bus. The high voltage side of the

transformer voltage corresponds according to the voltage of the generating unit that is 11 KV and the low voltage side that is stepped down to 6.6 KV.

3.2.1.2 Station Auxiliary System

A station auxiliary transformer is used to step down voltage from 6.6 KV to 440 V. The high voltage side of the transformer voltage corresponds to the voltage of the unit auxiliary transformer that is 6.6 KV and the low voltage side that is stepped down to 440V.

3.2.2 DC Auxiliary System

DC auxiliary system is used to feed essential services such as circuit breaker trip coils and associated relays, supervisory control and communications equipment. In DC auxiliary system there is used DC distribution board. A battery and a charger connected to the DC distribution bus. In this power plant Nickel Cadmium (Ni-Cd) batteries are used.

The equipment's that are needed for DC supply is given below:

- i. Mark VI Control System for GT (125 V DC)
- ii. Circuit breakers module control for power supply (110 V DC)
- iii. Field Instruments (24 V DC)
- iv. GT emergency drive panel (125V DC)
- v. GT solenoids (125 V DC)

3.3 Isolators

Isolator is used to isolate a circuit permanently after a fault occurs in the system. It is also used to isolate some part of the transmission line for maintenance. Isolator is an off-load device. In this power plant there are three isolators at high voltage switch yard.

3.4 Insulators

An insulator is used to prevent the flowing of undesired current. Valance electrons are tightly bonded in the insulating materials. So insulators are used to resist the flow of electrons. In this power plant there are two types of insulators. One is pin type and other is shackle type. Pin type insulator is used for 132 KV transmission line and shackle type insulator is used in low voltage transmission line.

3.5 Underground Cables

Underground cables consist of one or more conductors that are covered with suitable

insulation and surrounded by a protecting cover. In this power plant underground cables are used for grounding, metering and internal connection. Here XLPE cable is used and it ranges from 6.6KV to 33KV.

3.6 Bus Bars

Bus bar is a bar or line where different types of lines such as transmission line, distribution line etc. operates at the same voltage level. It is used to carry large current and distribute the current. In this power station, single bus bar, double bus bar and reserved bus bar are used. There are individual bus bars for 11/6.6 KV and 6.6KV/440V. The principle of double bus bar arrangement is to increase the flexibility of system. But in case of power failure the reserved bus bar is used.

3.7 Single line diagram

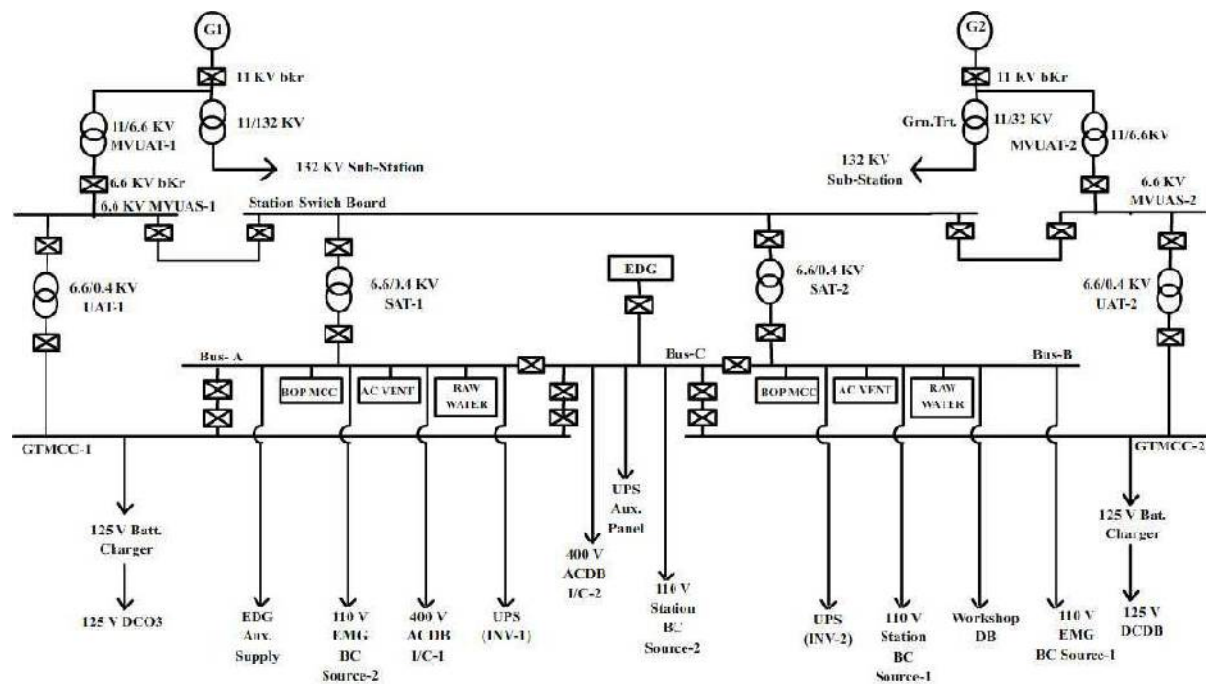

Figure 3.4: Single line diagram [2]

Single line diagram shows the all Bus bar connections of the power plant. Bus bar starts from two generators G1 and G2. There are different bus bars for 11/6.6KV and 6.6/0.4KV. The double bus bar is used to increase the flexibility of the whole system. In case of power failure the reserved bus bar can be used.

Chapter 4: Testing and Maintenance System

4.1 Transformer Maintenance and Oil Test

The insulation of a potential transformer and current transformers is used to the purpose of insulating as well as cooling system. Due to ageing and pollution of dust particles the oil of transformer deteriorates in its isolation and cooling system. For this reason we need to check oil level and oil acidity of transformer. If the acidity rate is between 0.5 mg to 1 mg KOH oil should be kept to inspection. So we need to check insulation resistance of the transformer every 6 months. In this power station Megger OTs100F is used for oil testing.

4.1.1 Routine Analysis

Routine test is essential for the transformer. In this power station there are several types of tests under the routine analysis. These tests are given below:

- i. To measure the transformer's winding resistance.
- ii. To measure the transformer's insulation resistance.
- iii. To measure the transformer's winding for high voltage and low voltage.
- iv. To measure the transformer's Induced over voltage withstand test(double voltage and double frequency test),
- v. To measure the no load loss and current.

4.1.2 Water Content Test

Water content test detects the moisture content in parts per million of the liquid insulation. It is an important test of electrical insulation. If the moisture content increases it can reduce the insulating properties of the oil. As a result dielectric breakdown occurs. The transformer becomes cool down for fluctuating temperature. Then dissolver water will become free due to poor insulating power and fluid degradation. Cellulose based paper which is used as insulation of the transformer's windings.

4.1.3 Acidity Test

Acidity test is a process that is used to test the fluid and declares the amount of oxidization. Oxidization decreases the dielectric property of the fluid. Acidity shows the chemical reaction with organic insulation. Transformer oils are oxidized owing to excessive temperature and oxygen. If the carboxylic acid is formed, then the amount of acidity will

increase. So this acidity acts as a catalyst. When the acidity approaches 0.3 mg KOH/g, then the transformer oil should be changed.

4.1.4 Dielectric Strength and Resistivity Test

Dielectric strength of the transformer oil is defined as the maximum voltage that can be applied across the fluid without electrical breakdown. When the breakdown voltage is low, the qualities of the transformer oil will poor. If the dielectric strength is decreased then the capacity of arc extinguishing will be decreased. It becomes better insulator due to higher dielectric strength. In this power plant “Megger” is used to test the oil for dielectric strength.



Figure 4.1: Oil testing machine-Megger OTs100F [2]

4.1.5 Dissolved Gas Analysis

Dissolved gas analysis is used to establish the concentrations of certain gases in the oil such as nitrogen, oxygen, hydrogen, carbon dioxide, carbon monoxide, methane, ethane, ethylene and methane. To detect the certain operational problems with the transformer, concentrations and relative ratios of the above gases are used. It may or may not be related with the change of physical or chemical property in the insulating oil.

4.1.6 Furan Analysis

Furan Analysis is used to measure the degradation of cellulose paper. During ageing the cellulose paper, it can reduce the amount of polymerization. Thus its mechanical strength decreases. The amount of polymerization of cellulose paper is directly related to the concentration of furan analysis in the oil. Furan analysis is formed due to the breakdown of the polymeric structure of cellulose paper.

4.1.7 Polychlorinated Biphenyl Test

Polychlorinated biphenyls are used as a dielectric fluid as they are not flammable. But the Production of Polychlorinated has been banned due to the accumulation and toxicity of their byproducts.

4.1.8 Fibers in Oil Test

Fibers are free from external contamination and insulating material around the windings. If the fibers are present, they can lead poor electric strength. Due to water in the oil these fibers become wet. The electric strength of the oil can be reduced due to the moisture of fibers.

4.1.9 Power Factor Test

Power factor of insulating oil is the ratio of real power and apparent power. Due to polar contaminants such as water, oxidized oil and cellulose paper degradation, power loss is happened in the transformer.

4.1.10 Breathing process

Breather is used in transformer which reduce the inside moisture. Silica gel is used in breather to absorb the moisture. Breather's health will good when the color of silica gel is blue .After absorbing the moisture silica gel color becomes pink. By observing the color of silica gel we can understand that it needs to be replaced.

4.2 Maintenance Process of Instrument Air or Plant Air Compressor

In this power plant there are two types of multi stages compressor such as instrument air (IA) and plant air (PA).These compressors are manufactured by "Chicago Pneumatic". The Original Equipment Manufacturer (OEM) maintenance is classified as 1500, 3000, 4500, 6000 hours intervals.

The tools which are used for maintenance purpose are given below:

- i. Vernier caliper,
- ii. Outside caliper
- iii. Ratchet 6-32,
- iv. Spanner 12-36,
- v. Pipe range,
- vi. Filler gauge
- vii. Rist cleaner,

- viii. Ball pin hammer,
- ix. Lifting belt,
- x. D socket,
- xi. Eye bolt,
- xii. Jack bolt,
- xiii. Mechanical screw driver sets etc.

4.3 Alternator Maintenance

The main sections for the maintenance of an alternator are winding insulation, cleaning of the rotor, bearing connection, and stator.

4.3.1 Winding Insulation

To measure the winding insulation resistances that are tested for broken strands, loose connections and high contact resistance in tap changers. Duration of measuring the winding insulation is 6 to 8 months at normal condition.

4.3.2 Bearing Connection

Temperature and vibration of the bearings are needed to check monthly. Proper grease is used for smooth bearing connection.

Chapter 5: Switchgear and Protection System

Switchgear is used to control the circuit breakers and motors of the power station. These elements can be operated automatically by control room or manually. Switchgear is operated by DC volt provided by DC auxiliary system. For protection purpose there is used 'MICOM' relay which is designed by Switzerland. This is a microcontroller based relay and it is used to protect various electrical equipments.

5.1 Generator Protection

Generator is a major component of power station. The prime mover is used to convert the electrical energy to mechanical energy as the intermediate stage. In this power station gas is main fuel.

5.1.1 Over-Current Protection

Generator operates continuously at rated power (KVA), frequency and power factor and the power factor range of percent (95 to 105) of rated value. When the generator operates at beyond rated KVA, it is harmful stator over current arises. It leads to overheating of stator and collapse of insulation. That is very risky for the generation units. Over-current relays identify fault currents and over-load currents. So over current protection is taken in this power station

5.1.2 Over-Voltage Protection

Over voltage is used to protect the electrical machine and connected electrical plant components from the effects of prohibited voltage increase. Over voltage occurs due to incorrect manual operation of the excitation system, (full) load shedding of a generator, separation of the generator from the system, faulty operation of the automatic voltage regulator etc

5.1.3 Over and under frequency Protection

The frequency protection system is essential to protect the generator against the high and low frequency. When large load-share is removed from the system the system frequency will be increased. On the other hand when the system experiences an increase in real power demand then the system frequency will be decreased. For protection purpose over frequency relays, under frequency relays or the combination of both relays are used for the load-frequency control.

5.1.4 Rotor Earth Fault Protection

Rotor earth fault protection is used to identify earth faults in the excitation circuit of synchronous machine. The earth fault in the rotor winding does not cause instant damage. If a second earth fault occurs then it forms a winding short circuit. As a result of magnetic imbalance mechanical force occurs that can damage the machine.

5.1.5 Under Excitation (Loss of field) Protection

Loss of field excitation occurs due to the failure of field open circuit, short circuit and Automatic Voltage Regulator (AVR). Then the generator acts as an induction motor. So, generator protection against loss of field excitation is very important.

5.1.6 Current Unbalance Protection

When three phase voltage of generator are different then current unbalance occurs. Due to current imbalance, high current is induced in the rotor of generator that leads to overheating of motor and burning of windings. So switchgear relay is used to compare the loads of various circuits

5.1.7 Transmission Line Protection

Transmission hazard stops the flow of electricity through the system. To detect the faulty situation of transmission line distance relay is used to protect the transmission line.

5.1.8 Distance Relay

Distance relay is double actuating quantity relay with one coil energized by current. Distance relay is used when the over current relay doesn't work properly. If a fault occurs in transmission line, the fault current increases and fault voltage reduces. So distance relay is used to protect the transmission line in power station.

5.2 Transformer Protection

In this power plant there are different types of transformers. So protection of transformers is very much important to ensure the flow of transmission to grid. Insulation breakdown, aging, over excitation, oil contamination, reduced cooling etc which are responsible for occurring fault in transformers. Some important transformer protection is given below:

5.2.1 Differential Protection

Differential Protection is very important for power transformer. Here differential relays are used to compare the primary current and the secondary current of power transformer. If there is found any unbalance condition, then the relay will actuate and inter-trip both the primary and secondary circuit breaker of the transformer.

5.2.2 Over-Current Protection

Over current protection is used to protect the transformer against fault current and overload current. Over current relay is used to protect the transformer which senses the impedance during short circuit condition.

5.2.3 Buchholz Relay

Buchholz relay is safety equipment that is used in the oil filled power transformers and the reactors. It lies on top of the 11/132 KV transformer. This is a gas-actuated relay which is installed in the oil immersed transformers for protection against various types of fault. Different types of gases such as H_2 , CO and CO_2 that are produced due to decomposition of transformer insulating oil will accumulate in the top part of the transformer oil container and it causes fall of oil level in it. When the oil level will fall, the alarm circuit will be energized that means the relay will be tripped.

5.3 Lightning Arrester

A lightning arrester is a device which is used to protect the insulation and conductors of the system from the damaging effects of lightning. . This arrester supplies a low impedance path to the ground for current from a lightning strike and restores to a typical operating situation. When the high voltage is greater than the normal line voltage, the arrester instantly furnishes a path to ground and reduces the excess voltage.

5.4 Circuit Breaker

A circuit breaker (CB) is an automatic switch. It stops the flow of electric current in a suddenly overloaded or otherwise abnormally stressed electric circuit. During abnormal conditions, when excessive current develops, a circuit breaker opens to protect equipment and surroundings from possible damage due to excess current. A CB can reset either automatically or manually at its normal operating condition. It does not need to be replacing like a fuse after operation.

There are different types of circuit breaker in this power plant. They are given below:

- Air circuit breaker (ACB),
- SF₆ circuit breaker,
- Vacuum circuit breaker (VCB),
- Miniature circuit breaker (MCB) and molded case circuit breaker (MCCB).

5.4.1 Air Circuit Breaker

Arc is an electric discharge between two electrodes. In order to interrupt the arc, air circuit breaker creates an arc voltage in excess of the supply voltage. The arc voltage is responsible for arcing. So the operation of the air circuit breaker is to increase arc voltage to prevent damage. It is used in bus bar and motor feeders. The panels of this circuit breaker are installed in switchgear panel room of the power station. If the circuit breaker is tripped, then the light flickers in those panels.



Figure 5.1: Air circuit breaker [2]

In this power station, there are two types of air circuit breaker (ACB). They are,

- i. Air blast circuit breaker (ABCB): It is used for the protection of 230 V line.
- ii. Air break circuit breaker (ACB): It is used for the protection of 400 V line.

5.4.2 SF₆ Circuit Breaker

A circuit breaker in which the current carrying contacts operate in sulphur hexafluoride (SF₆) gas is known as SF₆ circuit breaker. The rated voltage of this circuit breaker is 11 KV. SF₆ circuit breaker is filled with compressed sulphur-hexafluoride gas that actually helps to open

and close the switch contacts. It has high electro-negativity and excellent insulating property. It has also a large arc quenching medium so the arcing time is very short. In this power station SF₆ circuit breaker is used to protect the 11KV line.



Figure 5.2: SF₆ circuit breaker [2]

Table 5.1: Ratings of SF₆ circuit breaker [3]

Model	HECS-100M
Serial Number	HA3058-10
Rated Frequency	50 Hz
Max. operating voltage	13.2 KV
Rated voltage for pump motor drive	125 V DC
Rated control voltage for closing and trapping coils	125V DC
Rated operating SF ₆ density	40.7 kg/m ³
Current of the pump motor drive	6 A
Closing and trapping current	3 A

5.4.3 Vacuum circuit breaker

A circuit breaker in which vacuum is used as the arc quenching medium is known as vacuum circuit breaker (VCB). The rated current of this circuit breaker is up to 3000 A. In vacuum circuit breaker, two electrical contacts are enclosed in a vacuum. Here one contact is fixed and other contact is moveable. The dielectric strength of vacuum is higher than air and SF₆

gas. Due to high dielectric strength vacuum circuit breaker can quench a vacuum arc within very small contact gap.



Figure 5.3: Vacuum circuit breaker [2]

Table 5.2: Ratings of vacuum circuit breaker [3]

Manufacture name and collaborator	M/S BHEEL, BHOPAL
Type designator	VM 12 (820 mm)
Class	Indoor
Rated voltage	3.6/7.2/12 KV
Rated normal current	630/800/1250/1600/2000/2500/3150 A
Rated frequency	50 Hz
Number of poles	3
Auxiliary supply for closing trapping coil	24/30/110/220 V DC
Changing motor	230 V AC/220 V DC

5.4.4 Miniature Circuit Breaker and Molded Case Circuit Breaker

Miniature circuit breaker (MCB) has contact system that means of arc quenching, tripping and protection system to open the circuit breaker during fault condition. The operation of molded case circuit breaker (MCCB) is like as thermal or thermal magnetic operation. Both miniature circuit breaker and molded case circuit breaker are used to protect each phase individually. The rated voltage of these circuit breakers is 230V AC.

Chapter 6: Control system and instrumentation

The control system of this power plant is used to control the total operation of the power system. In EGCB, there are three types of control room. They are:

- i. Main control room,
- ii. Local computer based automatic control room
- iii. Manual control room

Different types of valves, pressure gauge, mechanical speed instruments, flame detectors, air flow transmitter are used for instrumentation purpose.

6.1 Main Control Room

The main control room is controlled by Max-DNA (Digital Network Architecture) and General Electric (GE) Mark-VI software.



Figure 6.1: Main control room [2]

6.1.1 Max-DNA control system

Max –DNA is used to distributed control system (DCS). It is used throughout the system. It is also a computerized control system. The total system of controllers is connected by networks which are used for communication and monitoring purpose. The functions of DCS are:

- i. To check the local instrumentation such as pressure, temperature and level gauges.
- ii. To control lube oil temperature through temperature control valve.
- iii. To clean seal gas inlet pressure control through pressure control valve.

6.1.2 GE Mark VI Control System

GE Mark VI is the 3rd generation of triple redundant control system. It was created in 1983. Mark VI control for GE turbine is considered as a complete integrated control. In this power station it is used for protection and monitoring the generator and mechanical drive applications of gas turbine.

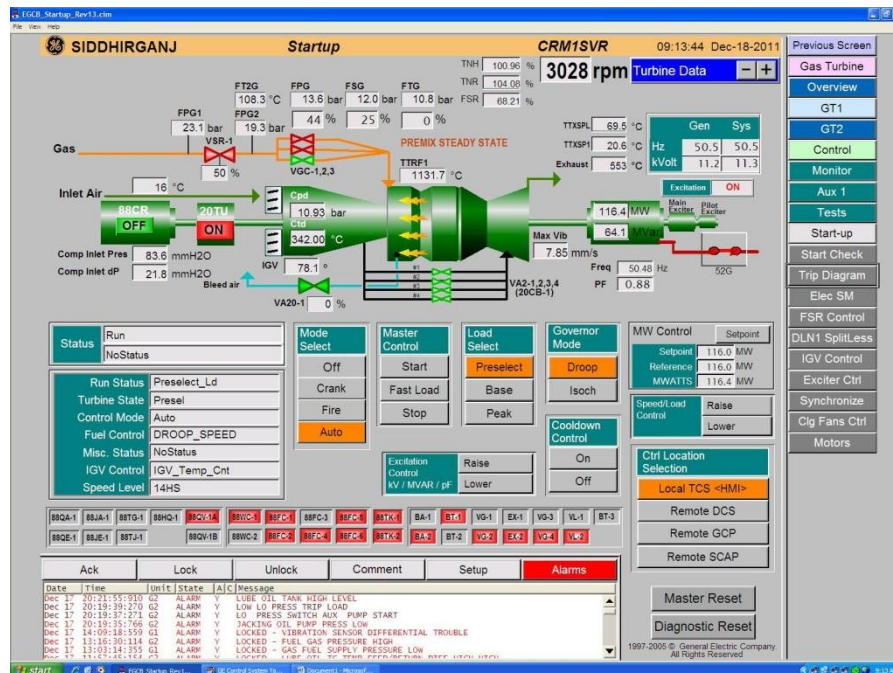

Figure 6.2: GE Mark VI control system [2]

6.2 Local Computer based Automatic Control Room

DCS is the combination of proportional-integral-derivative (PID) controllers. It is a computerized control system used to control the balance of plant. Max-DNA is the latest version of DCS that is developed by Metso Automation MAX Controls, USA. The Max-DNA control system is used for Frame 9E gas turbine. The main functions of Max-DNA control system are automatic startup, automatic speed control, automatic load control, frequency control, synchronization and valve testing. The protection functions consist of monitoring critical turbine parameters, over speed, trips for low hydraulic oil pressure, lube oil pressure, vacuum pressure, vibration, exhaust and flame control.

6.2.1 Water Feeding and Drum Level Control

The water feeding and drum level control system is used to maintain qualified steam o temperature is 5230°C and pressure is 135 BAR. A drum level sensor is used to respond the error between the actual drum level and its actual set points.

6.2.2 Air and Gas Control System

The proper amount of air and fuel gas is needed in combustion system. The actuator controls air collection from nature. On other side the gas control valve controls the flow of gas with load. Sensor senses the pressure of gas. If the pressure of gas falls then it gives signal to the computer monitor to take necessary steps.

6.2.3 Lube Oil Control System

Lube oil control system is very important for power plant. The lube oil is used to reduce the friction and cooling purpose. When the pressure of lube oil is low, the turbine will trip. To control the lube oil following steps should be taken:

- i. One lube oil pump should start and the other should standby.
- ii. Oil temperature after cooler should be at $45 \pm 5^\circ \text{C}$.
- iii. Drain oil temperature should be at 60°C to 65°C .
- iv. Oil sample analysis is required periodically.

6.2.4 Compressor Starting

To start the compressor following steps should be taken

- i. To check the lube oil line leakage,
- ii. To ensure that IA/PA/N₂ plant is in running condition,
- iii. To ensure that at least one lube oil pump is running,
- iv. To ensure that one cooling water module pump is running,
- v. To ensure that lube oil tank level and header pressure are at the required level etc.

6.2.5 Alarm System

An alarm is generated if the system parameters goes beyond or lower than tolerable limits.

The alarm that is generated in the DCS (distributed control system), is given below:

- i. Lube oil level low alarm
- ii. Lube oil high temperature alarm after coolers
- iii. Lube oil filter differential pressure high alarm
- iv. Lube oil header level low alarm
- v. Lube oil overhead level high and low alarm,
- vi. Compressor suction pressure high and low alarm

- vii. Seal gas filter (primary and secondary) differential pressure high alarm

6.3 Manual Control system

Manual control room is a switchgear control room where all the operations are done manually. In manual control room, there are different types of meters that are used to measure the readings. In this room there are various types of panels. They are:

- i. Generator transformer panel
- ii. Data Concentrator Panel
- iii. Gas Turbine Auxiliary Panel
- iv. Generator Relay Panel
- v. Generator Control Panel
- vi. Automatic Voltage Regulator



Figure 6.3: One side view of manual control room [2]

6.4 Controlling Valves

Valves are mechanical devices that can control the flow and pressures within a system. They are essential components of a piping system. The main functions of controlling valves are

- i. To stop or start flow
- ii. To Reduce or increase a flow
- iii. To control the direction of a flow
- iv. To regulate a flow

There are different types of controlling valves such as gate valve, globe valve, plug valve, butterfly valve, ball valve, swing check valve, diaphragm valve, pinch valve, safety valve and relief valve.

6.5 Pressure Gauge and Mechanical Speed Checking

Pressure gauge is mainly used to measure pressure in various parts of a boiler and also measure pressure of steam, air, oil, water and fluids.

Tachometer is used to check the mechanical speed. Basically frequency of generator depends on prime mover's speed. Here the speed is fixed at 3000 rpm. So tachometer is used to check the speed.

6.6 Flame Detector

Flame detector is used to detect flame in a burner. When the flame in a burner goes out then the flame detector sends a message to the fuel feed controller. Finally it automatically stops the flow of fuel into the burner.

6.7 Air Flow Transmitter

Air Flow Transmitter is a transducer. It is used for monitoring, control and regulation of airflow speed in fresh air etc. In this power plant, air flow transmitter is used to measure the flow of air into the burner.

6.8 Automatic Voltage Regulator (AVR)

When the rotor speed of generator runs at 2000 rpm, then DC supply goes off and excitation system turns on. At that time the output voltage is regulated by AVR. It can be controlled both manually and automatically.

Chapter 7: Operating Process of the Power Plant

7.1 Introduction

The operating process of the power plant depends on gas turbine, combustion chamber that is used to burn the fuel to start rotation in turbine blade. It takes air from the atmosphere and then the air is compressed to high pressure. From GBC, gas enters into combustion chamber by nozzle. By mixing air with fuel firing is occurred and the rotation of blade started to the combustion chamber.

7.2 Operating Modes

The operating mode uses in EGCB power plant is to reduce the emission of nitrogen oxide. In this power plant there are three types of operating modes. They are given below:

- i. Primary mode,
- ii. Lean-lean mode,
- iii. Premix steady state mode.

7.2.1 Primary mode

Primary mode is an essential part for gas turbine. The turbine acts in primary mode when the gas pressure is low. The fuel is provided to the primary nozzles. Primary mode is used to burn the fuel, accelerate and operate the machine over low load to mid load. When the plant is running in primary mode for a long time the turbine is hampered. In this power plant 45 MW power is generated in Primary mode.

7.2.2 Lean-Lean Mode

Lean-Lean Mode is the secondary mode for the gas turbine. When the gas pressure is medium the turbine operates in Lean-Lean Mode. Here the fuel is present both the in primary and secondary nozzles. Lean- Lean mode is used to transitional loads. Lean-Lean mode is used to generate 65 MW power in this power plant.

7.2.3 Premix steady state mode

When the gas pressure is high the plant operates in premix steady state mode. Fuel is present both in primary and secondary nozzles. In this mode optimum emissions are generated. The

Undergraduate Internship Report

turbine efficiency is maximum because of maximum output power. Premix mode normally produces 85 MW to 120 MW power in this power plant.

Chapter 8: Mechanical workshop

8.1 Overhead crane

An overhead crane is a type of crane that is used to heavy industrial lifting requirements, covering all parts of manufacturing process. There are two overhead cranes in this power station. The capacity of each crane is about 5 ton. In this power station overhead crane is used to shift heavy equipments and mechanical parts from one place to another.

8.2 Portable mobile crane

Portable mobile crane is a type of crane that is used for shifting purpose. In this power station it is used to place machinery equipments at the proper location.

8.3 Lathe machine

A lathe is a machine tool that is used for cutting, drilling, sanding or facing, turning, with tools that are applied to the work piece to create an object in this power station [5]. It is operated directly by manual lathes or computer controlled lathes. Centre Lathe machine is one kind of lathe machine. It is used to manufacture cylindrical shapes from a range of materials including steels and plastics.

8.4 Milling machine

Milling machine is used for making spear gear, helical gear etc. in this power station. For machining parts to accurate sizes and shapes it is used in this power station. The position of milling machine is either vertical or horizontal orientation to carve out materials based on a pre-existing design. There are two types of milling process such as: i. Face milling, ii. Peripheral milling [6].

8.5 Radial drill

Radial drilling machine is a designed to give the highest level of strength rigidity and are easy for the operation. Some of the major parts of the radial arm drilling machine are column, arm raise, on/off button, arm clamp, table, base, spindle, drill head, radial arm [7]. It has a drill head that is mounted on an arm assembly. It can be moved around to the extent of its arm reach. Radial drill is used to drill the small and large materials in this power plant.

8.6 Arc welding machine

Arc welding is the process of joining two metal pieces using a flux covered electrode. It is melted in an electric arc and becomes a fused part of the pieces being welded. Arc welding processes may be manual, semi-automatic, or fully automated [8]. It is used for joining different mechanical parts in this power station.

Chapter 9: Backup and Protection system

9.1 DC auxiliary system

EGCB power plant provides continuous DC power supply by using Nickel Cadmium Batteries. This section will deal with the auxiliary power supply using DC batteries for the plant.

9.1.1 Auxiliary DC power supply

The auxiliary power supply is provided by DC supply. The inverter is used to convert the DC supply to AC. In the backup panel the batteries are interconnected. Nickel cadmium battery provides 220V DC supply. In the control room there were two rectifiers. One is for supplying the DC to the control panel from the AC input and the other rectifier were used to back up the first rectifier. When charge is needed, the batteries are being charged, but when there is AC power supply, the batteries are in floating condition. In this state neither they get charged nor do they supply power. The rectifier itself supplies the DC to the control board from the input AC.



Figure 9.1: Auxiliary DC power supply [2]

9.1.2 Emergency Diesel Generator (EDG)

Emergency diesel generator (EDG) is a very essential part of the power plant. It is used as a backup system. If grid fails then EDG will start to work automatically and manually off. It has nickel cadmium (Ni-Cd) battery which is charged when the power station works.

9.2 N₂ plant

Nitrogen gas is used where there is a probability of firing. In a gas power plant gas is used as fuel. In GBC and GT there are many rotating parts. For the rotation there is a probability of sparking and for this any destruction is possible. To avoid this causality there is used nitrogen gas which stops the firing by sparking for rotational elements.



Figure 9.2: N₂ plant [2]

9.3 Firefighting system

Firefighting protection is important for EGCB power plant. In this power plant three types of systems are used to the fire protection.

- i. **Sensor system:** Here many sensor systems are used to detect the fire.
- ii. **Alarm system:** If any fire occurs in the power station then an alarm must be automatically activated.
- iii. **Fire extinguisher:** In this power plant various types of fire extinguishers are used. Mainly water extinguisher is used in the power plant. Water extinguishers are automatically activated when fire detector detects fire. Extinguishers are used around the transformer in the plant.

In this power plant, couples of CO₂ cylinders are present. The gas containing capacity of each cylinder is 6000 kg. When carbon dioxide is released it reduced the oxygen content of air. By a discharging nozzle CO₂ is discharged from high pressurized cylinder. Fire extinguishing

Undergraduate Internship Report

powders such as ammonium phosphate (NH_3PO_4), potassium bi carbonate (KHCO_3) are used to protect fire.



Figure 9.3: CO₂ Cylinder [2]

Chapter 10: Conclusion

10.1 Discussion

Power sector is very important part of our country. To increase the economic growth of a country we need electricity to run the industries. Bangladesh is a very small but largely populated country. Here the demand of electricity is increasing day by day. But the generation of power is not increased in the same way. For this reason load shedding occurs frequently. Bangladesh government has already taken many steps to fulfill the electricity demand of the country. Siddhirganj 2×120 MW peaking power plant was built for this purpose. Basically the purpose of this power plant is to run the plant at peak hours because at that time the demand of electricity is highest.

From this internship, we have learnt about the power generation, protection and maintenance process of this power plant. We have gathered practical knowledge from this power plant. During our internship we visited I&C (Instrumentation and Control) section, mechanical section, electrical section, maintenance section and fire safety section. The authorities of this power plant were concerned about all types of safety. The trainers tried their best to give us the overall view of this power plant. They were very friendly and they gave us a clear concept of this power plant. Through this internship we related our theoretical knowledge with practical knowledge. This practical knowledge will be very helpful for our future job sector.

10.2 Problems

There were some problems which we faced during our internship. They are given below:

- i. Due to the short length of the internship we could not understand all the sections of the power plant.
- ii. We had spent 3 days in mechanical section. But we faced different types of problems to understand the mechanical related sections. So we need at least one mechanical engineering course in our university.
- iii. The safety equipment is not available in this power plant.

10.3 Recommendations

After finishing our internship we want to recommend some information which are given below:

- i. Before starting the industrial training students should complete power station related courses such as Power Station, Switchgear or Power Electronics.
- ii. Everyone should aware of the precautions of a power station. Because power station is a high voltage area.
- iii. To understand the mechanical parts of power station university authority should offer minimum one course which is related to mechanical engineering.
- iv. The safety equipment's should be provided by the authority of the power station.
- v. The duration of internship period should be increased at least three months.

Appendix

EGCB = Electricity Generation Company of Bangladesh

BHEL = Bharat Heavy Electrical Ltd.

GBC = Gas Booster Compressor

CT = Current Transformer

PT= Potential Transformer

CB = Circuit Breaker

ACB = Air Circuit Breaker

ABCB = Air Blast Circuit Breaker

SF₆CB = Sulphur Hexafluoride Circuit Breaker

VCB = Vacuum Circuit Breaker

MCB = Miniature Circuit Breaker

MCCB= Molded Case Circuit Breaker

DCS = Distributed Control System

References

- [1] Power plant details-Siddhirganj 2×120 MW Peaking Power Plant. [Online].Available:
<http://www.egcb.com.bd/120mw.php>
- [2] Picture provided from Siddhirganj 2×120 MW Peaking Power Plant.
- [3] Data provided from Siddhirganj 2×120 MW Peaking Power Plant.
- [4] Materials provided by the mentors of Siddhirganj 2×120 MW Peaking Power Plant.
- [5] Lathe machine details. [Online]. Available:
<http://en.wikipedia.org/wiki/Lathe>
- [6] Milling machine details. [Online]. Available:
http://en.wikipedia.org/wiki/Milling_%28machining%29
- [7] Radial drilling machine details. [Online]. Available:
<http://www.brighthubengineering.com/manufacturing-technology/62030-radial-drilling-machine/>
- [8] Arc welding machine details. [Online]. Available:
http://en.wikipedia.org/wiki/Arc_welding
- [9] Transformer details. [Online]. Available:
<http://en.wikipedia.org/wiki/Transformer>
- [10] Induction details. [Online].Available:
http://en.wikipedia.org/wiki/Electromagnetic_induction

Daily Activity Report

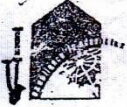

Department of Electrical and Electronic Engineering
 East West University
 EEE 499
 Industrial Training
 Daily Activity Report

Separate Daily Activity Report should be completed by each intern for every day of work and should be signed by the mentor from the company and the academic advisor. Copy of all the reports should be attached to the final internship report.

Name of the company:	EGCB
Name of the student:	Md. Shamiul Islam
ID:	2010-3-80-001

Date:	23/08/2014
Start time/End time	9.00 A.M. - 5.00 P.M.
Location:	Siddhinganj, Narayanganj
Mentor:	Md. Masud Alam

General Instructions:

- It is the intern's duty to make sure that all his/her daily activity reports are appropriately signed by both the mentor and the academic supervisor.
- The daily report should be a brief narration of the activities during the internship period in the eyes of the intern and should be completed and submitted by every intern irrespective of the number of partners s/he might have for the presentation and final report writing purpose.
- The report should not be a compilation of lectures notes taken during the internship, rather it should depict what the intern has learned on a particular day.
- In case of any confusion, interns are strongly recommended to consult their respective academic supervisors.



Department of Electrical and Electronic Engineering
East West University

Address the following points briefly (Use additional page if necessary)

1. What was the objective of the day's activities? (If applicable, list multiple objectives)

The objective of the day's was to visit the main control room and learn how the whole system is monitored and controlled using Mark-VI ~~software~~ software.

2. List the day's activities according to the order of objectives listed in 1. Mention the specifications of the equipments used/visited. Comment on how these activities fulfill your objectives.

The mentor showed us-

- GBC control system
- GT control system
- Water treatment plant
- Lube oil system
- Emergency backup system.

3. Relate your practical activity with the theoretical knowledge you gained in the respective academic course.

This is not related with our academic course and MarkVI software is new for us.

Mam:
23.08.14

Signature of the mentor with date
Name: Md. Masud Alam
Designation: Sub-division engineer
Contact Phone #: 01816581592

Alam 28/9/2014

Signature of academic supervisor with date
Name: Khairul Alam
Designation: Assoc Prof



Department of Electrical and Electronic Engineering
East West University
EEE 499
Industrial Training
Daily Activity Report

Separate Daily Activity Report should be completed by each intern for every day of work and should be signed by the mentor from the company and the academic advisor. Copy of all the reports should be attached to the final internship report.

Name of the company:	EGCB
Name of the student:	Md. Shamul Islam
ID:	2010-3-80-001
Date:	24/08/2014
Start time/End time	9.00 A.M. - 5.00 P.M.
Location:	Siddhingarj, Narayanganj
Mentor:	Md. Abu Sayeed

General Instructions:

- It is the intern's duty to make sure that all his/her daily activity reports are appropriately signed by both the mentor and the academic supervisor.
- The daily report should be a brief narration of the activities during the internship period in the eyes of the intern and should be completed and submitted by every intern irrespective of the number of partners s/he might have for the presentation and final report writing purpose.
- The report should not be a compilation of lectures notes taken during the internship, rather it should depict what the intern has learned on a particular day.
- In case of any confusion, interns are strongly recommended to consult their respective academic supervisors.



Department of Electrical and Electronic Engineering
East West University

Address the following points briefly (Use additional page if necessary)

1. What was the objective of the day's activities? (If applicable, list multiple objectives)

The objective of the day's activity was to learn about the single line diagram of the power plant.

2. List the day's activities according to the order of objectives listed in 1. Mention the specifications of the equipments used/visited. Comment on how these activities fulfill your objectives.

The mentor gave us an overview of the whole power plant. He showed us where step up, step down happens in transformer and how the CB and EDG works.

3. Relate your practical activity with the theoretical knowledge you gained in the respective academic course.

From the single line diagram, we have learnt about transformer, CB, Busbar which is related to EEE 303 and EEE 442.

24/8/14

Signature of the mentor with date

Name:

Designation: **MD. ABU SAYEED**

Contact Phone: **Sub-Divisional Engineer (Electrical)**

Siddhigani 2X120MW Peaking Power Plant
GECR Ltd., Siddhigani, Narayanganj
01554308028

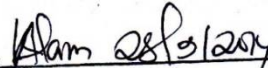
28/8/2014

Signature of academic supervisor with date

Name: **Khairul Alam**

Designation: **Assoc Prof**



Department of Electrical and Electronic Engineering
East West University
EEE 499
Industrial Training
Daily Activity Report

Separate Daily Activity Report should be completed by each intern for every day of work and should be signed by the mentor from the company and the academic advisor. Copy of all the reports should be attached to the final internship report.

Name of the company:	EGCB
Name of the student:	Md. Shamiul Islam
ID:	2010-3-80-001

Date:	25/08/2014
Start time/End time	9.00 A.M. - 5.00 P.M.
Location:	Siddhinganj, Narayanganj
Mentor:	Alip Sarder

General Instructions:

- It is the intern's duty to make sure that all his/her daily activity reports are appropriately signed by both the mentor and the academic supervisor.
- The daily report should be a brief narration of the activities during the internship period in the eyes of the intern and should be completed and submitted by every intern irrespective of the number of partners s/he might have for the presentation and final report writing purpose.
- The report should not be a compilation of lectures notes taken during the internship, rather it should depict what the intern has learned on a particular day.
- In case of any confusion, interns are strongly recommended to consult their respective academic supervisors.



Department of Electrical and Electronic Engineering
East West University

Address the following points briefly (Use additional page if necessary)

1. What was the objective of the day's activities? (If applicable, list multiple objectives)

The objective of the day's activities was to learn about the mechanical portion of power plant specially the GBC.

2. List the day's activities according to the order of objectives listed in 1. Mention the specifications of the equipments used/visited. Comment on how these activities fulfill your objectives.

The mentor gave us an overview of the power plant's mechanical portion. He showed us motor, gear box, Lub oil pumps, overhead crane and central air cooling system.

3. Relate your practical activity with the theoretical knowledge you gained in the respective academic course.

We have read the equipments in our academic course but here we have got the practical knowledge about the equipments.

Signature of the mentor with date
Name: Alip Sarder
Designation: SAE
Contact Phone #: 01 553297241

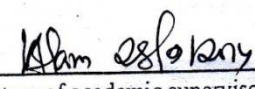
Signature of academic supervisor with date
Name: Khairul Alam
Designation: Assoc Prof

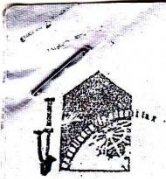

Department of Electrical and Electronic Engineering
 East West University
 EEE 499
 Industrial Training
 Daily Activity Report

Separate Daily Activity Report should be completed by each intern for every day of work and should be signed by the mentor from the company and the academic advisor. Copy of all the reports should be attached to the final internship report.

Name of the company:	EGCB
Name of the student:	Md. Shamiul Islam
ID:	2010-3-80-001

Date:	26/08/2014
Start time/End time	9.00 A.M. - 5.00 P.M.
Location:	Siddhirganj, Narayanganj
Mentor:	Alip Sarder

General Instructions:

- It is the intern's duty to make sure that all his/her daily activity reports are appropriately signed by both the mentor and the academic supervisor.
- The daily report should be a brief narration of the activities during the internship period in the eyes of the intern and should be completed and submitted by every intern irrespective of the number of partners s/he might have for the presentation and final report writing purpose.
- The report should not be a compilation of lectures notes taken during the internship, rather it should depict what the intern has learned on a particular day.
- In case of any confusion, interns are strongly recommended to consult their respective academic supervisors.



Department of Electrical and Electronic Engineering
East West University

Address the following points briefly (Use additional page if necessary)

1. What was the objective of the day's activities? (If applicable, list multiple objectives)

The objective of the day's activities was to understand about the mechanical portion of power plant.

2. List the day's activities according to the order of objectives listed in 1. Mention the specifications of the equipments used/visited. Comment on how these activities fulfill your objectives.

The mentor showed us:-

- i) JAPA compressor
- ii) Cooling water module
- iii) ~~AFC (air force controller)~~
- iv) Gran finitised filtration

3. Relate your practical activity with the theoretical knowledge you gained in the respective academic course.

We haven't read all the equipments in our academic course but here we got the practical knowledge about them.

Signature of the mentor with date
Name: Alip Sarden
Designation: SAE
Contact Phone #: 01553297241

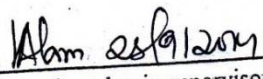
Signature of academic supervisor with date
Name: Khairul Alam
Designation: Assst. Prof.



Department of Electrical and Electronic Engineering
East West University
EEE 499
Industrial Training
Daily Activity Report

Separate Daily Activity Report should be completed by each intern for every day of work and should be signed by the mentor from the company and the academic advisor. Copy of all the reports should be attached to the final internship report.

Name of the company:	EGCB
Name of the student:	Md. Shamiul Islam
ID:	2020-3-80-002

Date:	27/08/2024
Start time/End time	9.00 A.M. - 5.00 P.M.
Location:	Siddhingarj, Narayangarj
Mentor:	Alip Sarder

General Instructions:

- It is the intern's duty to make sure that all his/her daily activity reports are appropriately signed by both the mentor and the academic supervisor.
- The daily report should be a brief narration of the activities during the internship period in the eyes of the intern and should be completed and submitted by every intern irrespective of the number of partners s/he might have for the presentation and final report writing purpose.
- The report should not be a compilation of lectures notes taken during the internship, rather it should depict what the intern has learned on a particular day.
- In case of any confusion, interns are strongly recommended to consult their respective academic supervisors.



Department of Electrical and Electronic Engineering
East West University

Address the following points briefly (Use additional page if necessary)

1. What was the objective of the day's activities? (If applicable, list multiple objectives)

The objective of the day's activity was to learn about the mechanical portion of power plant. ~~spa~~

2. List the day's activities according to the order of objectives listed in 1. Mention the specifications of the equipments used/visited. Comment on how these activities fulfill your objectives.

The mentor showed us -

- Workshop
- Portable mobile crane
- Drill machine
- Milling machine
- Press maker
- Arc welding machine

3. Relate your practical activity with the theoretical knowledge you gained in the respective academic course.

The equipments were new for us. Here we got the practical knowledge about them.

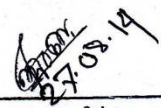
Signature of the mentor with date
Name: Alip Sarder
Designation: SAE
Contact Phone #: 01553297241

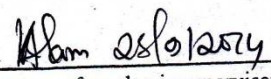
Signature of academic supervisor with date
Name: Khairul Alam
Designation: Assoc. Prof.

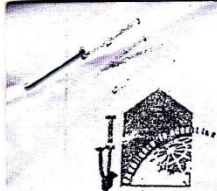

Department of Electrical and Electronic Engineering
East West University
EEE 499
Industrial Training
Daily Activity Report

Separate Daily Activity Report should be completed by each intern for every day of work and should be signed by the mentor from the company and the academic advisor. Copy of all the reports should be attached to the final internship report.

Name of the company:	EGCB
Name of the student:	Mithun Sarkar
ID:	2010-3-80-011

Date:	28-08-14
Start time/End time	9 AM - 5 PM
Location:	Siddhinganj, Narayanganj
Mentor:	Md. Abu Sayeed

General Instruction:

- It is the intern's duty to make sure that all his/her daily activity reports are appropriately signed by both the mentor and the academic supervisor.
- The daily report should be a brief narration of the activities during the internship period in the eyes of the intern and should be completed and submitted by every intern irrespective of the number of partners s/he might have for the presentation and final report writing purpose.
- The report should not be a compilation of lectures notes taken during the internship, rather it should depict what the intern has learned on a particular day.
- In case of any confusion, interns are strongly recommended to consult their respective academic supervisors.



Department of Electrical and Electronic Engineering
East West University

Address the following points briefly (Use additional page if necessary)

1. What was the objective of the day's activities? (If applicable, list multiple objectives)

The objective of the days activities was to learn about the transformers of the power station.

2. List the day's activities according to the order of objectives listed in 1. Mention the specifications of the equipments used/visited. Comment on how these activities fulfill your objectives.

The mentor showed us to Generator transformer (GCT), Mid voltage unit Auxillary transformer (MVUAT), Unit Auxillary transformers (UAT).

3. Relate your practical activity with the theoretical knowledge you gained in the respective academic course.

The activity of this day is related to our theoretical knowledge which we studied in the Electrical machine course

EEE 301

ABU SAYEED
Signature of the mentor with date
Name: **ABU SAYEED**
Designation: Divisional Engineer (Electrical)
Contact: 01554308028

Khairul Alam
Signature of academic supervisor with date
Name: **Khairul Alam**
Designation: **Assoc. Prof.**



Department of Electrical and Electronic Engineering
East West University
EEE 499
Industrial Training
Daily Activity Report

Separate Daily Activity Report should be completed by each intern for every day of work and should be signed by the mentor from the company and the academic advisor. Copy of all the reports should be attached to the final internship report.

Name of the company:	EGCB
Name of the student:	Mithun Sarkar
ID:	2010-3-80-011
Date:	30-8-14
Start time/End time	9:00 AM - 5:00 PM
Location:	Siddhinganj, Narayanganj
Mentor:	Md. Masud Alam

General Instructions:

- It is the intern's duty to make sure that all his/her daily activity reports are appropriately signed by both the mentor and the academic supervisor.
- The daily report should be a brief narration of the activities during the internship period in the eyes of the intern and should be completed and submitted by every intern irrespective of the number of partners s/he might have for the presentation and final report writing purpose.
- The report should not be a compilation of lectures notes taken during the internship, rather it should depict what the intern has learned on a particular day.
- In case of any confusion, interns are strongly recommended to consult their respective academic supervisors.



Department of Electrical and Electronic Engineering
East West University

Address the following points briefly (Use additional page if necessary)

1. What was the objective of the day's activities? (If applicable, list multiple objectives)

The objective of the day's activities was to visit the control room and its various operations.

2. List the day's activities according to the order of objectives listed in 1. Mention the specifications of the equipments used/visited. Comment on how these activities fulfill your objectives.

The mentor showed us to cooling module system, overview on how GBC work, start up, different valves, mode of operations, electrical system, and temperature control.

3. Relate your practical activity with the theoretical knowledge you gained in the respective academic course.

It is not related to our academic course of above mentioned equipment control system.

MAM. 30.08.14
Signature of the mentor with date
Name: MD. Masud Alam
Designation: Sub-division Engineer
Contact Phone #: 01816581592

Alam 28/9/2014
Signature of academic supervisor with date
Name: Khairul Alam
Designation: Assoc. Prof

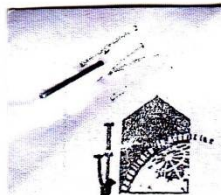

Department of Electrical and Electronic Engineering
East West University
EEE 499
Industrial Training
Daily Activity Report

Separate Daily Activity Report should be completed by each intern for every day of work and should be signed by the mentor from the company and the academic advisor. Copy of all the reports should be attached to the final internship report.

Name of the company:	EGCB
Name of the student:	Mithun Sarkar
ID:	2010-3-80-011

Date:	31-08-14
Start time/End time	9:00 AM - 5:00 PM
Location:	Siddhinganj, Narayanganj
Mentor:	Md. Abu Sayeed

General Instructions:

- It is the intern's duty to make sure that all his/her daily activity reports are appropriately signed by both the mentor and the academic supervisor.
- The daily report should be a brief narration of the activities during the internship period in the eyes of the intern and should be completed and submitted by every intern irrespective of the number of partners s/he might have for the presentation and final report writing purpose.
- The report should not be a compilation of lectures notes taken during the internship, rather it should depict what the intern has learned on a particular day.
- In case of any confusion, interns are strongly recommended to consult their respective academic supervisors.



Department of Electrical and Electronic Engineering
East West University

Address the following points briefly (Use additional page if necessary)

1. What was the objective of the day's activities? (If applicable, list multiple objectives)

The objective of the days activities was to visit about the transformers and the switch yard.

2. List the day's activities according to the order of objectives listed in 1. Mention the specifications of the equipments used/visited. Comment on how these activities fulfill your objectives.

The menton showed us, CT (current transformer), PT (potential transformer) Insulator, Isolator, and light arrested.

3. Relate your practical activity with the theoretical knowledge you gained in the respective academic course.

This day activity related to our theoretical course Electrical machine EEE 301.

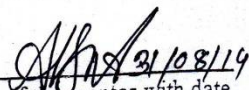
Signature of the mentor with date
Name: MD. ABU SAYEED
Sub-Divisional Engineer (Electrical)
Designation: Sub-Divisional Engineer (Electrical)
Contact Phone No: 0155430828

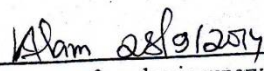
Signature of academic supervisor with date
Name: Khairul Alam
Designation: Assoc. Prof.



Department of Electrical and Electronic Engineering
East West University
EEE 499
Industrial Training
Daily Activity Report

Separate Daily Activity Report should be completed by each intern for every day of work and should be signed by the mentor from the company and the academic advisor. Copy of all the reports should be attached to the final internship report.

Name of the company:	EGCB
Name of the student:	Mithun Sankar
ID:	2010-3-80-011

Date:	01-09-14
Start time/End time	9.00 AM - 5.00 PM
Location:	Siddhinganj, Narayanganj
Mentor:	Md. Abu Sayeed

General Instructions:

- It is the intern's duty to make sure that all his/her daily activity reports are appropriately signed by both the mentor and the academic supervisor.
- The daily report should be a brief narration of the activities during the internship period in the eyes of the intern and should be completed and submitted by every intern irrespective of the number of partners s/he might have for the presentation and final report writing purpose.
- The report should not be a compilation of lectures notes taken during the internship, rather it should depict what the intern has learned on a particular day.
- In case of any confusion, interns are strongly recommended to consult their respective academic supervisors.



Department of Electrical and Electronic Engineering
East West University

Address the following points briefly (Use additional page if necessary)

1. What was the objective of the day's activities? (If applicable, list multiple objectives)

The objective of the day's activities was to visit about the gas turbine of the power station.

2. List the day's activities according to the order of objectives listed in 1. Mention the specifications of the equipments used/visited. Comment on how these activities fulfill your objectives.

The mentor showed us to, starting motor, gear box, torque converter cooling fan, turning gear, and mist eliminator

3. Relate your practical activity with the theoretical knowledge you gained in the respective academic course.

The activity of the day is related to our theoretical knowledge which we studied in the EEE 301 and EEE 304.

MD. ABU SAYEED
Signature of the mentor with date
Name: MD. ABU SAYEED
Designation: Divisional Engineer (Electrical)
Contact: 01554308028

Khairul Alam
Signature of academic supervisor with date
Name: Khairul Alam
Designation: Assoc. Prof.



Department of Electrical and Electronic Engineering
East West University
EEE 499
Industrial Training
Daily Activity Report

Separate Daily Activity Report should be completed by each intern for every day of work and should be signed by the mentor from the company and the academic advisor. Copy of all the reports should be attached to the final internship report.

Name of the company:	EGCB
Name of the student:	Mithun Sarkar
ID:	2010-3-80-011
Date:	02-09-14
Start time/End time	9:00 AM - 5:00 PM
Location:	Siddhinganj, Narayanganj
Mentor:	Md. Abu Sayeed

General Instructions:

- It is the intern's duty to make sure that all his/her daily activity reports are appropriately signed by both the mentor and the academic supervisor.
- The daily report should be a brief narration of the activities during the internship period in the eyes of the intern and should be completed and submitted by every intern irrespective of the number of partners s/he might have for the presentation and final report writing purpose.
- The report should not be a compilation of lectures notes taken during the internship, rather it should depict what the intern has learned on a particular day.
- In case of any confusion, interns are strongly recommended to consult their respective academic supervisors.



Department of Electrical and Electronic Engineering
East West University

Address the following points briefly (Use additional page if necessary)

1. What was the objective of the day's activities? (If applicable, list multiple objectives)

The objective of the day's activities was to learn about the combustion chamber and the inlet guide vane.

2. List the day's activities according to the order of objectives listed in 1. Mention the specifications of the equipments used/visited. Comment on how these activities fulfill your objectives.

The mentor told us about the Air filter of IGV, burner, flame detector, combustion chamber, tube oil system of GT, cross fire tube for firing.

3. Relate your practical activity with the theoretical knowledge you gained in the respective academic course.

The activity of this day is not related to our theoretical knowledge.

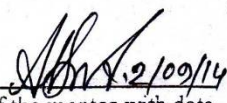
Signature of the mentor with date
Name: **MD. ABU SAYEED**
Designation: **Sub-Divisional Engineer (Electrical)**
Contact Person: **Siddhigani, Narayanan**
01554308028

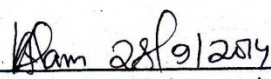
Signature of academic supervisor with date
Name: **Khairul Alam**
Designation: **Assoc. Prof**



Department of Electrical and Electronic Engineering
East West University
EEE 499
Industrial Training
Daily Activity Report

Separate Daily Activity Report should be completed by each intern for every day of work and should be signed by the mentor from the company and the academic advisor. Copy of all the reports should be attached to the final internship report.

Name of the company:	EGCB
Name of the student:	Abdullah At Asif
ID:	2010-3-80-029
Date:	03-09-14
Start time/End time	9:00 Am - 5:00 pm
Location:	Siddhirganj, Narayanganj
Mentor:	Md. Abu sayeed.

General Instruction:

- It is the intern's duty to make sure that all his/her daily activity reports are appropriately signed by both the mentor and the academic supervisor.
- The daily report should be a brief narration of the activities during the internship period in the eyes of the intern and should be completed and submitted by every intern irrespective of the number of papers s/he might have for the presentation and final report writing purpose.
- The report should not be a compilation of lectures notes taken during the internship, rather it should depict what the intern has learned on a particular day.
- In case of any confusion, interns are strongly recommended to consult their respective academic supervisors.



Department of Electrical and Electronic Engineering
East West University

Address the following points briefly (Use additional page if necessary)

1. What was the objective of the day's activities? (If applicable, list multiple objectives)
The objective of the day's activity to learn about the generating unit and PMG.

2. List the day's activities according to the order of objectives listed in 1. Mention the specifications of the equipments used/visited. Comment on how these activities fulfill your objectives.

The mentore showed us,
→ PMG
→ Joternal Bearing
→ Carbon brush.
The mentore tell us, about,
→ Excitation,
→ Stator.
→ Field (Rotor).

3. Relate your practical activity with the theoretical knowledge you gained in the respective academic course.

This is related to our theoretical course which we studied in EEE B01 and 304.

Signature: Abu Sayeed Date: 3/09/14
Name: **ABU SAYEED**
Designation: **Divisional Engineer (Electrical)**
Contact Phone #: **01554308028**

Signature: Khairul Alam Date: 28/9/2014
Name: **Khairul Alam**
Designation: **Asst. Prof.**



Department of Electrical and Electronic Engineering
 East West University
 EEE 499
 Industrial Training
 Daily Activity Report

Separate Daily Activity Report should be completed by each intern for every day of work and should be signed by the mentor from the company and the academic advisor. Copy of all the reports should be attached to the final internship report.

Name of the company:	EGCB
Name of the student:	Abdullah Al Asif
ID:	2010-3-80-029
Date:	04-09-14
Start time/End time	9:00 AM - 5:00 PM
Location:	Siddhirganj, Narayanganj
Mentor:	Md. Abu sayeed

General Instruction:

- It is the intern's duty to make sure that all his/her daily activity reports are appropriately signed by both the mentor and the academic supervisor.
- The daily report should be a brief narration of the activities during the internship period in the eyes of the intern and should be completed and submitted by every intern irrespective of the number of partners s/he might have for the presentation and final report writing purpose.
- The report should not be a compilation of lectures notes taken during the internship, rather it should depict what the intern has learned on a particular day.
- In case of any confusion, interns are strongly recommended to consult their respective academic supervisors.



Department of Electrical and Electronic Engineering
East West University

Address the following points briefly (Use additional page if necessary)

1. What was the objective of the day's activities? (If applicable, list multiple objectives)

The objective of the days activity is to learn about switchgear.

2. List the day's activities according to the order of objectives listed in 1. Mention the specifications of the equipments used/visited. Comment on how these activities fulfill your objectives.

- Air circuit Breaker (ACB)
- Vacuum circuit Breaker (VCB)
- SF6 circuit Breaker

Above those are showed by our mentore and he ^{told} us about their operationg. We also see MCCB. and relays.

3. Relate your practical activity with the theoretical knowledge you gained in the respective academic course.

This is related to our theoretical course which we studied in EEE 442.

Signature: Abu Sayeed with date 4/09/14
Name: **ABU SAYEED**
Sub-Divisional Engineer (Electrical)
Designation: **Sub-Divisional Engineer (Electrical)**
Contact Phone #: 01554308028

Signature: Khairul Alam with date 28/9/2014
Name: **Khairul Alam**
Designation: **Assoc. Prof**



Department of Electrical and Electronic Engineering
East West University
EEE 499
Industrial Training
Daily Activity Report

Separate Daily Activity Report should be completed by each intern for every day of work and should be signed by the mentor from the company and the academic advisor. Copy of all the reports should be attached to the final internship report.

Name of the company:	EGCB
Name of the student:	Abdullah Al Asif
ID:	2010-3-80-029
Date:	06-09-14
Start time/End time	9:00am 5:00 pm
Location:	Shiddhirganj, Narayanganj
Mentor:	Md. Abdu sayeed

General Instruction:

- It is the intern's duty to make sure that all his/her daily activity reports are appropriately signed by both the mentor and the academic supervisor.
- The daily report should be a brief narration of the activities during the internship period in the eyes of the intern and should be completed and submitted by every intern irrespective of the number of papers s/he might have for the presentation and final report writing purpose.
- The report should not be a compilation of lectures notes taken during the internship, rather it should depict what the intern has learned on a particular day.
- In case of any confusion, interns are strongly recommended to consult their respective academic supervisors.



Department of Electrical and Electronic Engineering
East West University

Address the following points briefly (Use additional page if necessary)

1. What was the objective of the day's activities? (If applicable, list multiple objectives)

The objective of the day's activity is to learn about switchgear, ~~and~~ transformer protection and testing.

2. List the day's activities according to the order of objectives listed in 1. Mention the specifications of the equipments used/visited. Comment on how these activities fulfill your objectives.

The mentor showed us,
→ Gas turbine motor control Circuit (GT MCC)
→ PMCC
→ SAT.
→ Synchronization process.
→ Silica gel check.
→ Conservator (oil test)

3. Relate your practical activity with the theoretical knowledge you gained in the respective academic course.

This is related to our theoretical course which we studied in EEE 304 and EEE 442.

Signature: MD ABUSAYEED with date 16/09/14
Name: Sub-Divisional Engineer (Electrical)
Designation: Siddhigang, 2X120MW Peaking Power Plant, Siddhygani, Narayanganj.
Contact Phone #: 01554308028

Signature of academic supervisor with date Alam 28/9/2014
Name: Khairul Alam
Designation: Assoc. Prof.



Department of Electrical and Electronic Engineering
 East West University
 EEE 499
 Industrial Training
 Daily Activity Report

Separate Daily Activity Report should be completed by each intern for every day of work and should be signed by the mentor from the company and the academic advisor. Copy of all the reports should be attached to the final internship report.

Name of the company:	EGCB
Name of the student:	Abdullah Al Asif
ID:	2010-3-80-029

Date:	13-09-14
Start time/End time	9:00 AM - 5 PM
Location:	Siddhirganj, Narayanganj
Mentor:	Md. Masud Golam Mostafa Khan

General Instruction:

- It is the intern's duty to make sure that all his/her daily activity reports are appropriately signed by both the mentor and the academic supervisor.
- The daily report should be a brief narration of the activities during the internship period in the eyes of the intern and should be completed and submitted by every intern irrespective of the number of partners s/he might have for the presentation and final report writing purpose.
- The report should not be a compilation of lectures notes taken during the internship, rather it should depict what the intern has learned on a particular day.
- In case of any confusion, interns are strongly recommended to consult their respective academic supervisors.



Department of Electrical and Electronic Engineering
East West University

Address the following points briefly (Use additional page if necessary)

1. What was the objective of the day's activities? (If applicable, list multiple objectives)

The objective of the day's activity was to learn about bearings and synchronization process.

2. List the day's activities according to the order of objectives listed in 1. Mention the specifications of the equipments used/visited. Comment on how these activities fulfill your objectives.

The mentor showed us.

- Journal bearing.
- Thrust bearing.
- Gas turbine startup sequence.
- Synchronization.

3. Relate your practical activity with the theoretical knowledge you gained in the respective academic course.

This is related to our theoretical knowledge which we study in EEE 301 and EEE 304.

Md. Golum
13.9.14

Signature of the mentor with date

Name:

Designation:

Contact Phone #:

Md. Golum Mortuza Khan
Sub-Divisional Engineer (Operation)
Siddhirgon 2x120 MW Peaking Power Plant
EGCB Ltd, Siddhirgonj, Narayangonj.

01710-797485

Alam 28/9/2014

Signature of academic supervisor with date

Name: **Khairul Alam**

Designation: **Assoc. Prof.**



Department of Electrical and Electronic Engineering
East West University
EEE 499
Industrial Training
Daily Activity Report

Separate Daily Activity Report should be completed by each intern for every day of work and should be signed by the mentor from the company and the academic advisor. Copy of all the reports should be attached to the final internship report.

Name of the company:	EGCB
Name of the student:	Abdullah Al Azif
ID:	2010-3-80-029
Date:	20-09-14
Start time/End time	9:00 Am - 5:00 pm
Location:	Siddhirganj, Narayanganj
Mentor:	Md. Golum Morshed Khan.

General Instruction:

- It is the intern's duty to make sure that all his/her daily activity reports are appropriately signed by both the mentor and the academic supervisor.
- The daily report should be a brief narration of the activities during the internship period in the eyes of the intern and should be completed and submitted by every intern irrespective of the number of paragraphs s/he might have for the presentation and final report writing purpose.
- The report should not be a compilation of lectures notes taken during the internship, rather it should depict what the intern has learned on a particular day.
- In case of any confusion, interns are strongly recommended to consult their respective academic supervisors.



Department of Electrical and Electronic Engineering
East West University

Address the following points briefly (Use additional page if necessary)

1. What was the objective of the day's activities? (If applicable, list multiple objectives)

The day's objective was a training to learn about fire fighting and safety procedure.

2. List the day's activities according to the order of objectives listed in 1. Mention the specifications of the equipments used/visited. Comment on how these activities fulfill your objectives.

The mentor showed us,

→ CO₂ system.

→ Hydrant system

→ N₂ gas fire extinguishing system.

→ Fire fighting room.

3. Relate your practical activity with the theoretical knowledge you gained in the respective academic course.

This is related to our theoretical knowledge BEE442.

Huse
20.9.14

Signature of the mentor with date

Name:

Designation:

Contact Phone #:

Md. Golam Mortuza Khan
Sub-Divisional Engineer (Operation)
Siddhirgon 2x120 MW Peaking Power Plant
EGCB Ltd, Siddhirgon, Dhaka, Bangladesh

01710-797485

Alam 28/9/2014

Signature of academic supervisor with date

Name: Khairul Alam

Designation: Assoc. Prof.