

# **Performance Analysis of a Grid-Tied Solar PV System**

By

Lamiya Sayed,  
Md. Hasanujjaman, and  
Md. Asadul Jaman

Submitted to the

Department of Electrical and Electronic Engineering  
Faculty of Sciences and Engineering  
East West University

In partial fulfillment of the requirements for the degree of Bachelor of Science  
in Electrical and Electronic Engineering (B.Sc. in EEE)

Spring 2018

Approved by

---

Thesis Supervisor  
Dr. Anisul Haque  
Professor, Department of EEE  
East West University

---

Chairperson  
Dr. Mohammad Mojammel Al Hakim  
Professor, Department of EEE  
East West University

## ABSTRACT

A grid tied solar PV system can provide energy to the consumers without affecting the climate. Due to minimal maintenance cost and longevity of the inverters and PV panels the grid tied PV system makes itself attractive to the customer. In this work, we have presented the performance analysis of a 200kWp grid-tied photovoltaic (PV) system installed on the rooftop of the Bangladesh Bureau of Statistics Building in Agargaon, Dhaka.

Real time output voltage, power, current and energy have been recorded for the month of December 2017. The input solar irradiance is calculated analytically to estimate the system efficiency. All the input and output data were collected and calculated, respectively, based on 1-hour interval. We have observed a maximum and minimum daily energy production of 471.9kWh and 94.5kWh respectively from the PV system. During that observation period, total 9670.5kWh energy is delivered by the PV system. The PV modules of this PV system have maximum 15.4% conversion efficiency and the inverters have maximum 98% inversion efficiency. In that case the maximum theoretical efficiency of the system is 15.1%.

Considering clear sky irradiance to the collector without considering the shadowing effect the PV system has 4.94% of monthly average overall efficiency. When we have considered the shadowing effect and clearness index separately, the monthly average overall efficiencies are 5.12% and 7.13% respectively. After considering both the clearness index and shadowing effect the monthly average overall efficiency of the PV system is 7.50%. The PV system has 1.75h/day of average daily final yield and 4.13h/day of average peak sun hours. Capacity factor of this PV system is 6.9% where it should be close to 15%. Average performance ratio is 0.42 during the observation period, however a properly functioning PV system has a performance ratio from 0.6 to 0.8 depending on geographical location and time of the year. Practically it is possible to get a higher system efficiency from this PV system by reducing dirt loss as it exhibits maximum overall efficiency of 10.11% after two days of drizzle.

After analyzing the efficiency and other parameters it can be concluded that the system performance is poor. We have found out that the lack of maintenance is one of the main reasons that reduces the efficiency of the PV system. Performance of the PV system can be improved by periodic cleaning of the PV panels and proper monitoring of the inverters and combiner boxes.

## **ACKNOWLEDGEMENT**

We would like to thank our thesis supervisor, Professor Dr. Anisul Haque, Department of Electrical and Electronic Engineering, East West University, Dhaka, Bangladesh for continuous supervision. He has guided us in every step of our work by his productive suggestions and support, without which the thesis work may not be completed successfully.

We would like to express our gratitude to Professor and Chairperson Dr. Mohammad Mojammel Al Hakim, Department of Electrical and Electronic Engineering, East West University, Dhaka, Bangladesh.

We would like to thank Engr. Mr. Md. Anamul Haque, Maintenance Engineer, Bangladesh Bureau of Statistics, Agargaon, Dhaka for providing us with the necessary permissions and instructions to observe the performance of the PV system that we have selected.

We would also like to express our gratefulness to Md. Bulbul Haque, Assistant at lift control room for his supports and appreciations. This person has played a great role in our work, without whom this work will become so tough for us. He has collected most data from time to time from the PV system and provided to us as we have required.

And finally, we have appreciated our parents and friends as they have provided us the major inspirations in every step of our study as well as in our real life.

## AUTHORIZATION PAGE

I hereby declare that I am the sole author of this thesis. I authorize East West University to lend this thesis to other institutions or individuals for the purpose of scholarly research.

---

Lamiya Sayed  
ID: 2014-1-80-047

---

Md. Hasanujjaman  
ID: 2014-2-80-005

---

Md. Asadul Jaman  
ID: 2014-2-80-052

I further authorize East West University to reproduce this thesis by photocopy or other means, in total or in part, at the request of other institutions or individuals for the purpose of scholarly research.

---

Lamiya Sayed  
ID: 2014-1-80-047

---

Md. Hasanujjaman  
ID: 2014-2-80-005

---

Md. Asadul Jaman  
ID: 2014-2-80-052

# TABLE OF CONTENTS

<b>List of Tables</b>	<b>07</b>
<b>List of Figures</b>	<b>08</b>
<b>Chapter 1   Introduction</b>	<b>09</b>
1.1 Background	09
1.2 Motivation	09
1.3 Literature Review	10
1.4 Objectives	12
1.5 Thesis Outline	12
<b>Chapter 2   Grid-Tied PV Systems</b>	<b>14</b>
2.1 Introduction	14
2.2 Components of Grid-Tied PV System	14
2.2.1 PV Arrays	14
2.2.2 MPPT	15
2.2.3 Inverters	17
2.2.4 Combiner Box	17
2.2.5 Safety Equipment	18
2.3 Types of Grid-Tied PV System	18
2.4 Connection Topologies	21
2.5 Summary	23
<b>Chapter 3   Impact of Grid-Tied PV System</b>	<b>24</b>
3.1 Overview	24
3.2 Advantages of Grid-Tied PV System	24
3.3 Problems Associated with Grid-Tied PV System	25
3.3.1 Variation of Generated Power	25
3.3.2 Variation of Frequency of Generated AC Power	26
3.3.3 Solar Irradiance Measurement	26

3.4 Impact on Transmission Network	27
3.5 Impact on Distribution Network	27
3.6 Financial Impact	28
<b>Chapter 4   Performance Analysis</b>	<b>30</b>
4.1 Introduction	30
4.2 System Specifications	30
4.3 Performance Matrices	35
4.3.1 Final Yield	35
4.3.2 Reference Yield	35
4.3.3 Performance Ratio	35
4.3.4 Capacity Factor	36
4.4 Solar Irradiance Calculation	36
4.5 Clearness Index Calculation	38
4.6 Solar Insolation Considering Clearness Index	39
4.7 Analysis of Collected Data	40
4.8 Investigation of System Performance	46
4.9 Proposal for Increasing the Performance	50
4.10 Summary	53
<b>Chapter 5   Conclusion</b>	<b>54</b>
5.1 Summary	54
5.2 Future Work	55
<b>References</b>	<b>56</b>

## LIST OF TABLES

Table 4.1: Specification of ESM300 300Wp solar panel.	30
Table 4.2: Technical specification of SUNNY TRIPOWER STP 17000TL-10 inverter.	31
Table 4.3: Estimation of ' $\alpha$ '.	41
Table 4.4: Number of shaded panels due to self-shadowing and building.	43
Table 4.5: Input and output energies of the PV system.	44
Table 4.6: Efficiencies of the PV system considering clearness index and shadowing.	45
Table 4.7: Values of performance matrices for the PV system.	49

## LIST OF FIGURES

Figure 2.1: Solar PV Panels.	15
Figure 2.2: I-V Characteristics of Solar PV cell.	15
Figure 2.3: Effect of variable solar insolation on maximum power point.	16
Figure 2.4: Output waveforms of square wave, modified sine wave & pure sine wave inverters.	17
Figure 2.5: Grid-tied solar PV system with backup storages supplying AC power.	19
Figure 2.6: Grid-tied solar PV system without backup storages supplying AC power.	20
Figure 2.7: Grid-tied solar PV system with backup storages supplying DC power.	20
Figure 2.8: Grid-tied solar PV system without backup storages supplying DC power.	21
Figure 2.9: Connection topologies of grid-tied PV systems.	21
Figure 4.1: Block diagram of the whole PV system.	33
Figure 4.2: (a) Combiner box that combines the inverters, (b) central combiner box that interfaces the PV system with grid connection.	34
Figure 4.3: Power vs. time curve with polynomial fitting for December 3, 2017.	40
Figure 4.4: Shadowing due to building at – (a) 1 PM – 2 PM, (b) 2 PM – 3 PM, (c) 3 PM – 4 PM, (d) 4 PM – 5 PM.	42
Figure 4.5: Self-shadowing at – (a) 1 PM – 2 PM, (b) 2 PM – 3 PM, (c) 3 PM – 4 PM, (d) 4 PM – 5 PM.	42
Figure 4.6: Daily input and output energies of the PV system.	47
Figure 4.7: Overall efficiency of the PV system.	47
Figure 4.8: PV panels of the system.	51
Figure 4.9: Close up of the panels of the PV system.	51
Figure 4.10: Solar panel after cleaning.	52



## CHAPTER 1

# INTRODUCTION

### 1.1 Background

Mostly in late 20<sup>th</sup> century, questions have been raised muscularly against the harmful effects of traditional fossil fuel, natural gas, coal or nuclear power plants to the climate. Recently, to meet the excessive power demand associated with extreme industrial development, most of the countries are trying to increase the use of renewable and sustainable energy sources such as hydro power, solar PV, wind turbine, geothermal heat energy and other energy sources to produce electricity [1]. Solar power has the highest potentiality and solar PV can be used all over the world to extract electrical energy from solar energy. Global warming, limitations of traditional energy sources and availability of solar energy have drawn our attention to extract electrical energy from solar energy. Many countries already have gained grid parity on energy from solar PV and many other countries are pursuing solar PV a lot to reach the grid parity on this renewable energy source [1]. We have a large number of solar home systems and a significant number of mid-size solar PV plants with a capacity of roughly around 100kWp to 500kWp. If the potentiality of those power plants has been utilized to the fullest extent then there will be significant energy contributions to the national grid and hence the power crisis will be reduced.

### 1.2 Motivation

From the beginning of 21<sup>st</sup> century, the use of renewable sources is increasing rapidly. The recently published report of National Renewable Energy Laboratory titled as “2016 Renewable Energy Data Book” shows that cumulative capacity of globally installed renewable electricity has increased by 9.1% from the year of 2006 to 2016 [2]. In 2016, 26% of total worldwide electricity generations has come from renewable sources and 15% of this portion has come from solar power [2].

There are a large number of mid-size and large solar PV plants that are in operation in Bangladesh. Bangladesh has a satisfying solar insolation and sunrise to sunset time duration

which is compatible for generating electricity from sunlight. Several stand-alone and grid tied solar PV plants are in operation in Bangladesh. According to Bangladesh Power Development Board an 8MWp and 3MWp grid connected PV plant, a 650kWp mini grid for remote area and a 30MWp solar park project are under implementation [3].

Bangladesh has implemented a vast amount of solar PV plants and a lot of projects are under pipeline. Performance of the existing PV plants need to be analyzed to ensure the optimal energy production as well as to determine whether the solar PV plants are operating as expected.

By analyzing the performance of a solar PV system, we can determine the system efficiency and the causes of different losses. Once the factors of declination in energy production of a PV system are identified, we can take proper action to minimize the losses which will increase the efficiency of the PV system.

Thus, the energy production of a PV plant can be increased, at the same time a guideline can be developed for other plants either already implemented or under design.

For these reasons, we have selected to analyze the performance of a roof top fixed 200kWp grid tied solar PV plant located at the Bangladesh Bureau of Statistics, Agargaon, Dhaka.

### **1.3 Literature Review**

Solar PV based power plants are among the best alternation of traditional power plants and the only option for remote areas where grid connection is not available or marine cable is the only option to supply from national grid. Therefore, the number of solar PV plants are significantly increasing day by day. To ensure the maximum energy production from the solar PV plant, the performance should be monitored and maintained so that the plant can utilize possible maximum energy from sunlight.

According to the Sustainable and Renewable Energy Development Authority (SREDA), including off grid renewable energy based power sources, the total electricity generation of our county is 16,289.63MW and among this 473.63MW is generated from renewable sources, which is 2.91% of total generation [4]. 239.65MW power is generated by solar PV systems that is 50.6% of total generation from renewable sources [4]. There are 11 solar PV mini-grids in operation in Bangladesh and the cumulative capacity of those plants is 2.19MW [4]. A 3MW

solar park is also in operation [4]. A total of 26 on-grid and 36 off-grid roof top solar PV plants are in operation with a cumulative capacity of 13.35MW and 14.81MW respectively [4].

Mainly solar PV based power plants are of two types – grid-tied or on-grid and stand alone or off grid. Main components of a grid-tied solar PV system are obviously solar PV panels, Inverters, combiner box if required, and safety of protective components, such as, circuit breakers and fuses. To observe the performance of a plant we need to observe the real time input energy or solar insolation and energy generation. Subsequently we can compare the actual generation and the expected generation.

Solar insolation will be calculated analytically as explained by Masters [5]. Using those models, we can estimate the actual input energy from sunlight to the solar PV panel considering the weather conditions, geographic location and time of the year.

Bano *et al.* has analyzed the performance of a 1MW grid-tied solar PV plant in Jaipur, India [6]. In this paper the array yield, reference yield, final yield and capacity factor were determined [6]. To measure the system losses, array capture loss was explained as a cumulative loss of wiring, string diodes, low irradiance, partial shadowing, mismatching, maximum power tracking errors and dust loss [6]. System losses were consisting of DC to AC conversion loss and loss caused by passive circuit elements [6].

Chowdhury *et al.* has analyzed the performance characteristics of grid connected building integrated solar photovoltaic applications in Bangladesh [7]. Considering the atmospheric condition of Bangladesh some important factors such as partial shading effect on the PV cell, solar irradiance, cell temperature, ideality factor, clearness index, tilt angle, azimuth angle and fill factor have been focused in this report [7]. Tilt angle, azimuth angle, clearness index, ideality factor and shading effect have been found as the most influencing factors and also mentioned that power loss due to shading effect can be minimized by 15.8% using two diode protection schemes [7].

Rahman *et al.* have also observed the performance of a 6.08kWp grid connected solar PV system at Malaysian Energy Centre, Malaysia [8]. An irradiance sensor and two temperature sensors have been installed and externally connected to the PV system via the inverter to obtain the solar irradiance and to monitor the ambient temperature and module temperature profiles at the site [8]. Performance ratio, final yield, and system efficiency were investigated [8]. AC and DC power measurement were also done to calculate the inverter efficiency [8].

## **1.4 Objectives**

The core purpose of this work is to analyze the performance of the solar PV plant and to determine if necessary, the factors that are responsible for performance degradation.

For this purpose, we will observe the daily energy generation for a certain time period from the particular solar PV system that we have selected. We will also estimate the daily solar insolation on the collector to estimate the system efficiency. We will observe the effects of some factors that degrade the system performance, such as, self-shadowing, dirt loss, sky clearness index etc. We will also estimate the fraction of energy losses due to these factors if necessary.

We will also attempt to develop a guideline for other existing as well as under implementation solar PV plants to ensure the maximum possible energy production. For analyzing the performance of the PV plant, we will calculate some parameters such as array yield, final yield, reference yield, performance ratio and capacity factor. Solar insolation and sky clearness index will also be estimated to determine the efficiency of the plant.

## **1.5 Thesis Outline**

This thesis report contains five chapter. A brief description of each chapter is given below.

Chapter 1 introduces the background and availability of solar energy. A brief description on recent renewable energy generation and its potential is given. Motivation of using solar PV plant is discussed here. The main objective and a brief literature review on our thesis work is added in this chapter. Over all a brief overview of our thesis work is given here before going to deep analysis.

Chapter 2 consists of basic description of grid-tied solar PV plant. The definition, classification and components of this PV plant is discussed in this chapter. The connection topology will also be discussed here.

Chapter 3 includes the impact of grid-tied solar PV plant, mostly the effect of this plant on the national grid is focused here. The advantages of will also be discussed in this part.

Chapter 4 consists of the main analytical and mathematical calculations. All the performance matrices are explained here. Graphs and tables will be added here to observe the efficiency and overall performance of the system.

Chapter 5 summarizes our thesis work that contains conclusion and future work.

References and appendices are added at the end of the report.

## CHAPTER 2

# GRID-TIED PV SYSTEMS

### 2.1 Introduction

Solar PV systems are usually of two types – stand alone or off-grid and grid-tied or on-grid. Both kinds of systems can be different in capacity, a system can be from several watts to several megawatts range. In this chapter we will discuss about the basic classifications of grid connected solar PV systems and the main components of the systems. We will also try to provide a basic idea on the connection topologies of PV systems. Block diagrams will be provided for better understanding.

### 2.2 Components of Grid-Tied PV System

Main components of a grid-tied PV system are PV arrays, MPPT, inverters, combiner box and safety and protective equipment. Some plants may not require inverters and combiner box, but in this section, we will try to provide a brief description of these components.

#### 2.2.1 PV Arrays

Solar PV arrays are the heart of any system that extracts electrical energy from the sunlight. Usually solar cells absorb sunlight and produces free electrons and holes that travels through the closed-circuit path. In this method, current flows through the connected load. Generally, a single solar cell can produce a very small amount of power. Therefore, a large number of solar cells are assembled together as a panel for a particular power generation. In a solar PV plant there are many solar panels are connected in series to get the required voltage and a series of panels is called string. Many strings are connected in parallel to get a higher current as required by the system. The whole series and parallel combination of a solar panels finally act as a single power supply to the load.

The series and parallel combination of solar panels are shown as block diagram in figure 2.1.

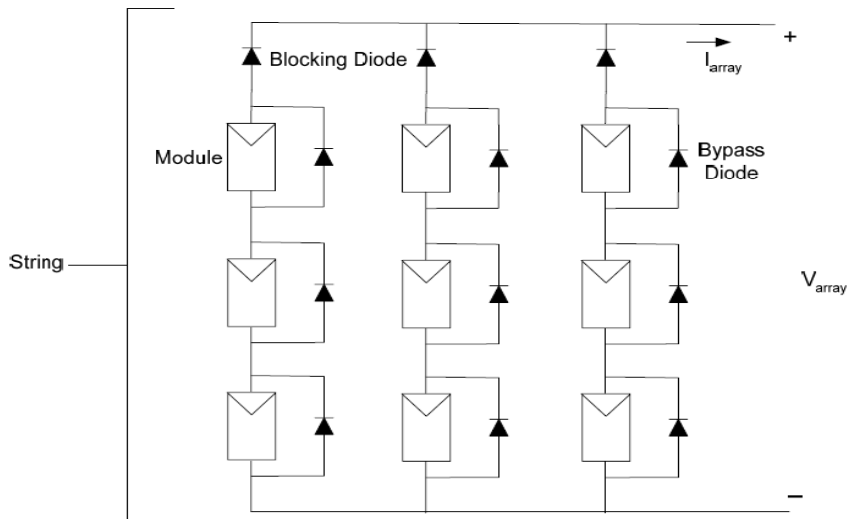

Figure 2.1: Solar PV Panels.

Here, bypass diodes are required to protect the module from damage due to module shadowing because potential damaging hot spots can be created in shaded cells [5]. Bypass diode can protect individual modules but if a whole string becomes shaded then it may be possible that the shaded string starts drawing current from the rest of the strings connected in parallel instead of supplying current [5]. By placing a blocking diode or isolation diode at the top of each string as shown in the figure 2.1, the reverse current drawn by the shaded string can be prevented [5].

### 2.2.2 MPPT

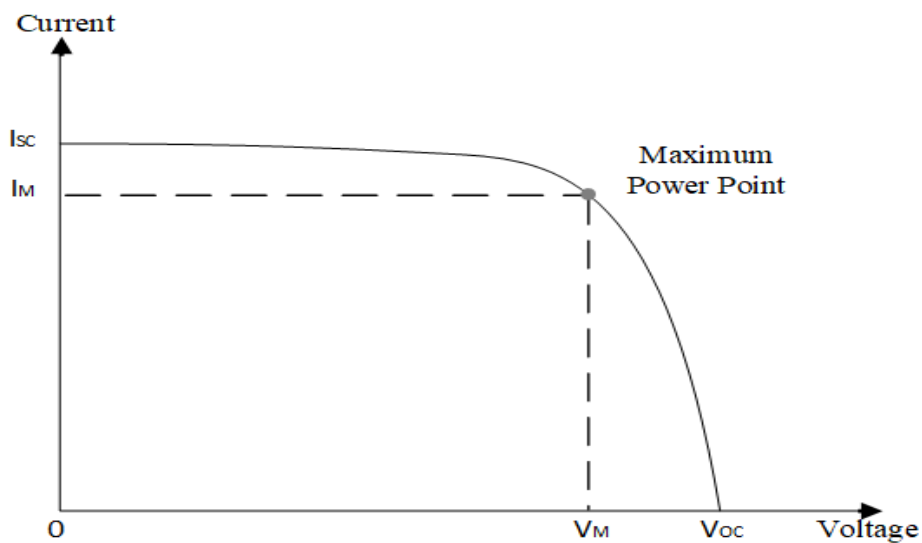

Figure 2.2: I-V Characteristics of Solar PV cell.

From the I-V characteristics of a solar cell as shown in figure 2.2 we can see that short circuit current ( $I_{sc}$ ) is the maximum current and open circuit voltage ( $V_{oc}$ ) is the maximum voltage that can be generated by the cell separately. Therefore, the maximum theoretical power generation from the cell is  $V_{oc}I_{sc}$ . But in practice a particular operating point is denoted as the maximum operating point that is called maximum power point (MPP) [5]. The corresponding current and voltage on that point is  $I_m$  and  $V_m$ .  $V_m I_m$  is the power of that maximum power point. But this figure is only for uniform solar insolation. The insolation over a whole day is not uniform. Here effect of variable solar insolation on maximum power point is shown in figure 2.3.

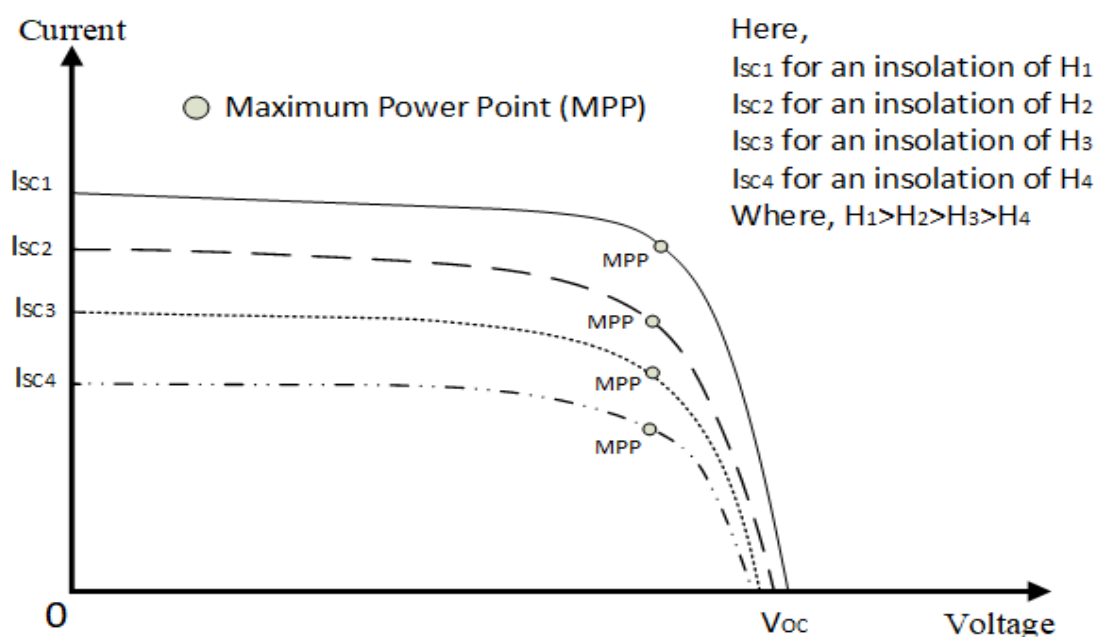

Figure 2.3: Effect of variable solar insolation on maximum power point.

Here, we can see that the maximum power point is changing when the insolation is changed. That means the operating point has changed. But for a fixed load, operating point cannot be changed as the power requirement is fixed for a fixed load. Therefore, we need a device that will vary our power requirement with varying the solar insolation to set the operating point close to the maximum power point. This kind of device is called maximum power point tracker (MPPT) [5]. MPPT will provide some extra power to the load when the load requires a higher power than that of maximum power point and consumes some extra power by its own when load requires a lower power than that of maximum power point. Combination of capacitor, inductor, transformer and some power electronic components are used to implement such devices.



### 2.2.3 Inverters

Solar PV can generate only DC power in its output. But most of the loads we use are AC load. Therefore, to run the AC loads using solar PV we have to invert the DC output of solar PV into AC. For this purpose, we use a device that is called inverter. Usually three types of inverters are used – square wave, modified sine wave and pure sine wave. Square wave inverters simply provide an AC square wave in its output and this type of inverter is the cheapest inverter. In modified sine wave inverter usually pulse width modulation technology and simple low pass filter is used that allows to pass only the required frequencies and blocks the harmonics but the filter is unable to smooth the output signal. In pure sine wave inverters, at first a modified sine wave is generated and then a very sensitive and high quality low pass filter is used for smoothing the waveform to get a pure sin wave in output. This kind of inverter is required where a stable pure sine wave AC output is required and the frequency tolerance is not acceptable. Wave forms of these three kinds of inverters are given in figure 2.4.

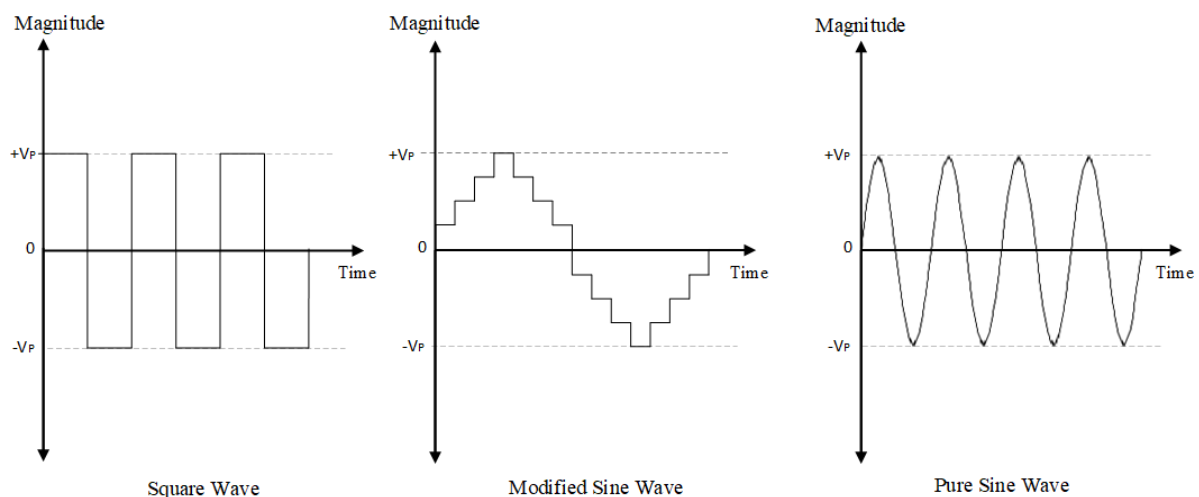

Figure 2.4: Output waveforms of square wave, modified sine wave & pure sine wave inverters.

### 2.2.4 Combiner box:

If a solar PV system has used only one centralized inverter then the output can directly be supplied to the grid or load. But if more than one inverter is used then the output of every single inverter has to be combined together and then it can be supplied. For this purpose, we generally use a bus system where all the outputs from individual inverters are connected and in some

cases safety equipment such as circuit breakers can be present to isolate any individual inverter section in case of any faulty situation.

### **2.2.5 Safety Equipment**

Usually in a grid-tied solar PV system, most of the safety measurements is required to protect the solar PV panels and the inverters as these are the major equipment of a PV system. Most of the safety measurements are provided internally with the inverter. Short-circuit diode and string fuse are used to protect the reverse polarity situation. DC over voltage and over current circuit breakers are used in the input side of the inverter. AC over current circuit breakers are used in the output of the inverter to avoid the short-circuit situation at the load side. In some inverters string failure detection and ground-fault detection are also added for better protection. If combiner box is present then there also circuit breakers are used to isolate individual inverter in case of any emergency. Where the final single or three phase lines are coupled with the grid, over voltage and over current protections are added on that point to protect the whole system.

### **2.3 Types of Grid-Tied PV System**

Off-grid PV systems can be used to supply DC loads or sometimes AC loads. But a grid-tied solar PV system usually supplies AC electricity to the AC grid or can be used to supply to a particular feeder line along with the grid connection to minimize the energy consumption from the grid. In some countries where DC grid line is available, solar PV system can directly supply the DC power to the DC grid.

A grid-tied solar PV plant may have backup battery storages to ensure uninterrupted power supply to the grid or the system may have no energy storages. Both types of PV systems are briefly explained here.

- **With backup storages:**

Usually grid-tied PV systems are used to supply the extra energy to the grid at day time to meet the peak demand without overloading the main power station. But in some situation at night time extra energy or backup energy is required. In that case battery

storages are used along with the PV system. In day time solar PV charges the battery storages as well as supplies electrical power to the grid after charging the batteries. Inverters are used to convert DC power into AC power [9], [10].

A block diagram showing the overview of grid-tied solar PV system supplying AC power with battery storages is given in figure 2.5.

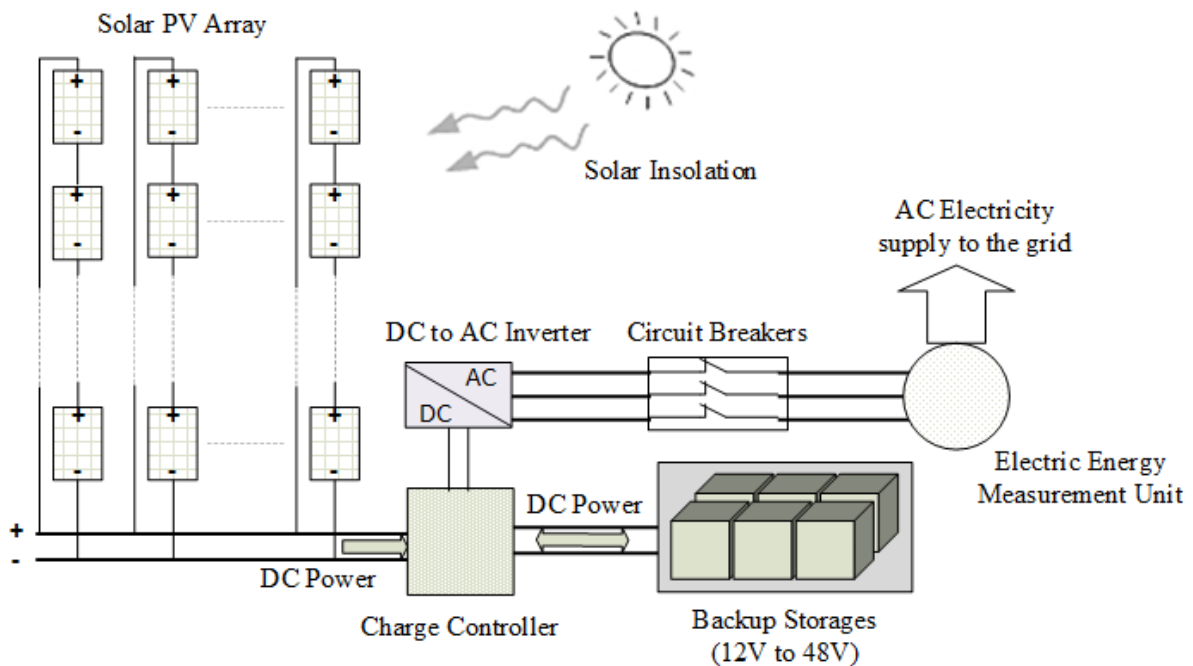

Figure 2.5: Grid-tied solar PV system with backup storages supplying AC power.

- **Without backup storages:**

Sometimes solar PV systems directly supply the generated power to the AC grid connection or to a particular feeder line along with the grid connection without any backup storage. In this case the system only provides energy at day time. This type of PV system requires less maintenance than a solar PV system with backup storages and more economically efficient when the capacity of PV plant goes up [9], [10].

A block diagram showing the overview of this type of grid-tied solar PV system is given in figure 2.6.

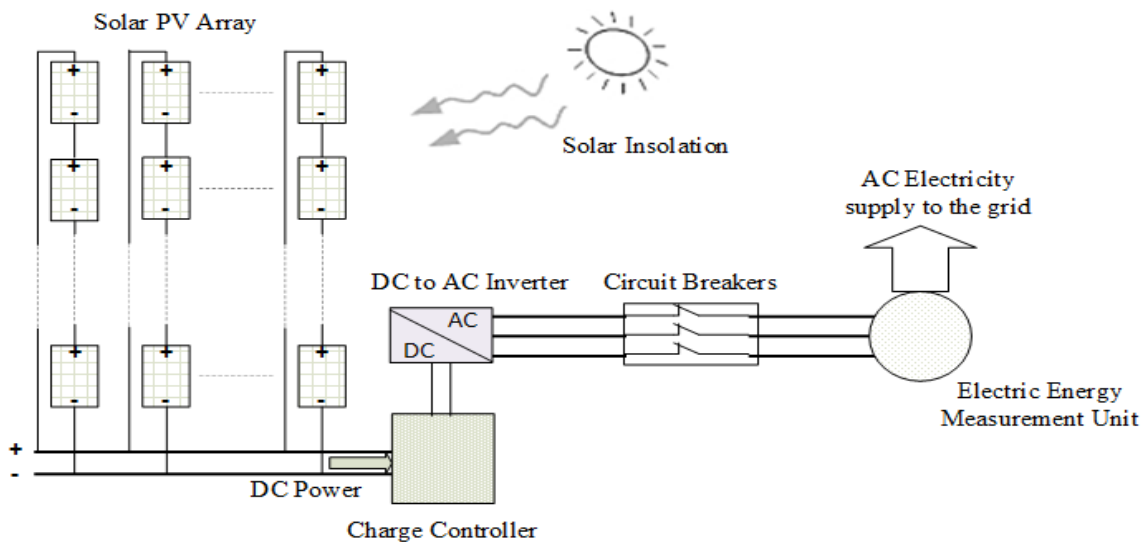

Figure 2.6: Grid-tied solar PV system without backup storages supplying AC power.

Finally, we can summarize that a solar PV plant can be two types in terms of grid types. If the grid is AC then the PV plant must supply AC power to the grid and inverter is mandatory to convert the generated DC power to AC. If DC transmission line and sub stations are available, in that case inverter is not required and DC power can directly be transmitted to the DC grid. In both cases, the plant may have backup battery storages or may not. Block diagrams of PV plant that is used to supply AC power to the grid with backup storages and without backup storages are shown in figure 2.5 and figure 2.6. Here a PV plants that is used to supply DC power to DC grid with backup storages and without backup storages is shown in figure 2.7 and figure 2.8.

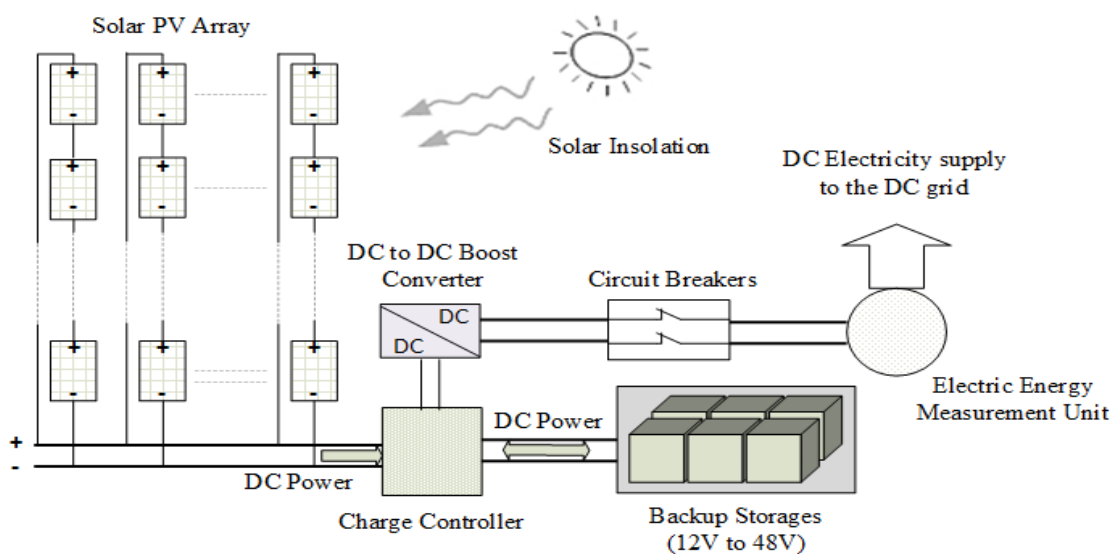

Figure 2.7: Grid-tied solar PV system with backup storages supplying DC power.

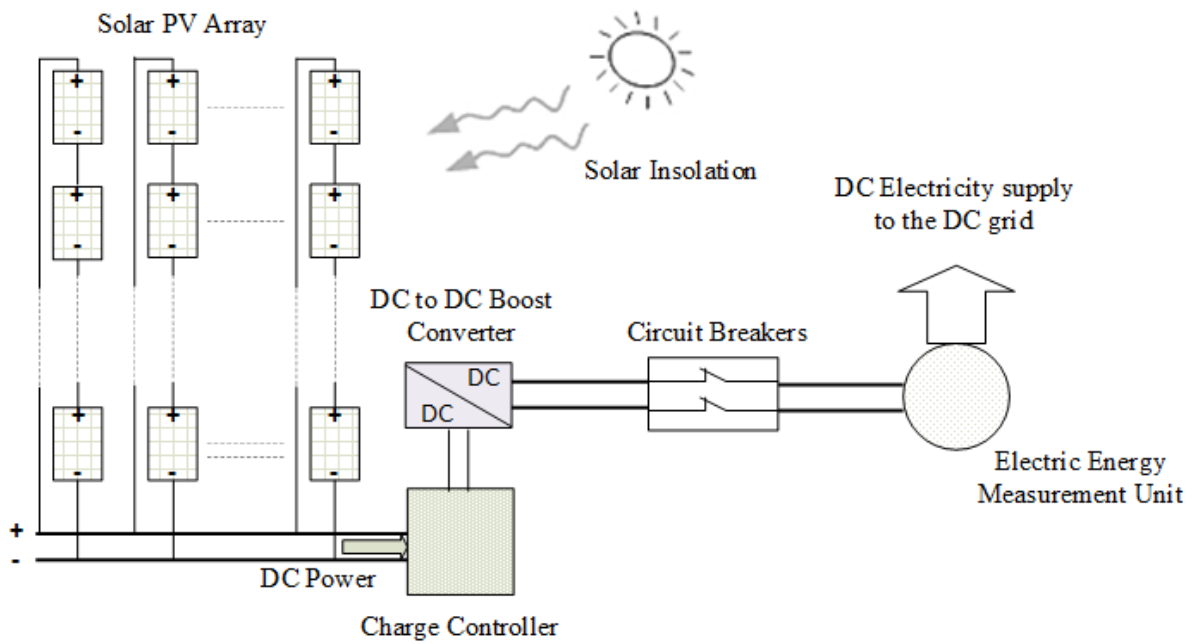

Figure 2.8: Grid-tied solar PV system without backup storages supplying DC power.

## 2.4 Connection Topologies

Grid connected solar PV systems have different connection topologies according to the connection of PV panels and inverters. Most common topologies are centralized inverter, master-slave, string to inverter, team concept, multi string and modular [11], [12], [13], [14]. A diagram consisting of all the topologies are given in figure 2.9.

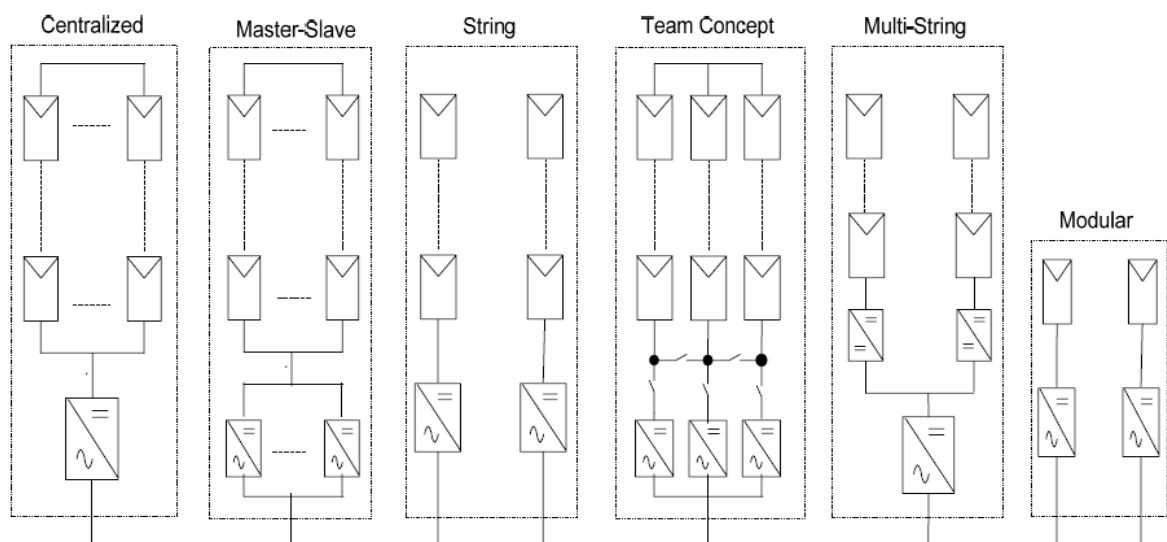

Figure 2.9: Connection topologies of grid-tied PV systems.

- **Centralized Inverter Topology:**

This topology is very cost effective for high power output such as several megawatts. Only one inverter is used that minimizes the DC to AC conversion loss. But if the inverter is failed the system goes down. Only one inverter means MPPT is also centralized. Therefore, the power rating of MPPT should be very high that may reduce the accuracy of tracking the maximum power point. Power loss for array mismatch is a big issue here.

- **Master-Slave Topology:**

Here, a master inverter is working along with a slave inverter. It is more reliable than centralized inverter topology as it has a backup inverter. It is costlier than the previous one and the power loss due to array mismatch is still present here.

- **String to Inverter Topology:**

In this topology each string is connected with an individual inverter. The system is more reliable in terms of PV panel failure. Every inverter separately tracks the maximum power point for each string so that the accuracy of tracking maximum power point is improved in this topology. Replacing or maintenance of PV panel or inverter is easier in this method.

- **Team Concept Topology:**

In this topology both the string concept and master slave concept are present. We can use any of the topologies as our requirements. It is normally used for very large PV systems. For low irradiance, all the PV arrays are connected into master-slave topology and for higher irradiance all the strings are separately connected with the individual inverters to track the maximum power point more accurately.

- **Multi-String Topology:**

Here, each string is connected to a DC-DC converter with MPPT to track the maximum power point and voltage amplification. All the outputs of DC-DC converters are connected in bus and goes to the centralized inverter. It has advantages on maximum power point tracking as each string tracks the maximum power point separately but as

it uses only one centralized inverter it is less reliable in case of any failure that may shut down the whole system.

- **Modular Topology:**

It is the latest topology and also denotes as it uses AC modules. In this topology all the inverters are embedded with the modules. It has many advantages like less or approximately no array mismatch loss as all the modules are connected separately with the inverters. It has a better monitoring of module failure and most flexible system that reduces the maintenance cost. Moreover, the lifetime of inverter reduces here as the inverters are mounted with the modules that increases the thermal stress on the inverters.

## **2.5 Summary**

In this chapter we have discussed briefly about the fundamental components of a grid connected solar PV system. We have also discussed the connection topologies that are generally used to implement a solar PV power plant. We have tried to mention the associated advantages and disadvantages of all the connection topologies.

## CHAPTER 3

# IMPACT OF GRID-TIED PV SYSTEM

### 3.1 Overview

Solar PV systems are most common in Bangladesh as small size off-grid solar home system in remote area where grid connection is unavailable. In present days, the use of large or medium size solar PV system is significantly increasing. The awareness of global warming and the fast advancing of technologies are the main reasons behind influencing people to pursue solar PV systems in large applications. When the PV system is used to supply electricity to the grid line, the irregular nature of output power might impose some challenges to operate the PV system as required. In this chapter, we will explore the advantages, challenges and impacts of a grid-tied solar PV system.

### 3.2 Advantages of Grid-Tied PV System

Environmental pollution, global warming and possible insufficiency of fossil fuel reserves are considered as the major driving forces that are behind the necessity of installing solar grid-tied PV systems. In remote areas, stand-alone large or medium size solar PV systems can be installed for supplying electricity to the consumers. Majority of urban consumers are using electricity from the grid that is produced by traditional fossil fuel based power plants. To reduce the production of electricity from such type of power plants, grid-tied renewable and sustainable energy based power plants are the solitary substitutes. For this purpose, grid-tied solar PV systems are the best power sources which may supply a huge amount of electrical energy to the grid.

Solar PV technology is growing so fast that some countries have already reached the grid parity in electricity from solar PV [1]. Once the grid parity is achieved on solar PV system, we will get electrical energy from grid-tied solar PV systems at a same price as we are getting from a typical power plant, however the harmful effects of that portion of energy generation are eliminated.



Grid-tied PV systems have some significant benefits to the utility companies too, particularly if the consumers are located far away from the load center. In that case PV systems can be installed on the feeder lines to decrease the feeder losses and to improve the voltage profile of the feeder line [15], [16]. A better voltage profile in a distribution type substation requires less maintenance costs for transformer and its load tap changers [17]. If the peak loading of feeder line is matched with the peak output of the PV system, then the loading of some transformers can be reduced at peak load periods in a network [18].

Therefore, we can summarize that grid-connected PV systems can provide some significant benefits such as environmental benefits, benefits to the electric utilities such as better voltage profile at load side, power loss reduction and less maintenance costs of the electric network.

### **3.3 Problems Associated with Grid-Tied PV System**

A grid-tied solar PV system has some significant benefits, though some challenges have to be faced to ensure the proper operation of the PV system. The only input energy for a solar PV is the sunlight, but the sunlight is not uniform all over the day. Due to the variable solar insolation a PV system generates variable powers on its output corresponding to the amount of solar insolation [19], [20], [21]. When the PV system is used to supply to an AC grid then the frequency of the generated power is one of the most important factors that has to be kept stable as required. Another important task is to determine the actual total input energy to the PV system [22]. In this section we will briefly explain some challenges that have to be faced in a grid-tied solar PV system.

#### **3.3.1 Variation of Generated Power**

It is obvious that solar insolation varies over the day, but due to clouds or other weather issues such as foggy day or rain, the insolation varies a lot. Such situations are the main reasons behind the variation of generated output power that is not desired in any PV system [19], [20], [21]. Jewell et al. has reported that around 10 cloud patterns, with squall lines and cumulus clouds are the major reason that varies the output power of a PV system [23]. Squall lines are the most extreme case that can cause the output power of the PV plant to be zero, however such worst case can be predicted and the periods of time can also be predicted when the system may go

out of service [23]. Cumulus clouds can fluctuate the output power of the PV system more frequently but it causes a lower loss as the solar insolation slightly fluctuates because of such clouds [23].

Therefore, it is obvious that we can never entirely eliminate the fluctuations of output power of a solar PV system. It is possible to improve the stability of generated power by proper weather forecasting, selection of connection topology, size of PV system and the available metrological data for a particular location.

### **3.3.2 Variation of Frequency of Generated AC Power**

We have already discussed that a solar PV system faces power fluctuations in output due to some obvious reasons. The power as well as the current of PV system varies. The effects that varies the voltage are also the reasons that varies the current. Moreover, self-shadowing is another issue that varies the current of PV panel [5].

Most of the inverters used in grid-tied solar PV system are designed on the basis of automatic feedback-controlled method to get a stable pure sine wave output with a constant frequency. When the fluctuation becomes very frequent, it is possible that the frequency of the output may fluctuate [24]. When the input power fluctuates significantly, the high frequency harmonic components may appear on the output [24]. For grid-tied PV system the frequency must be stable because the grid can never tolerate any fluctuation in frequency.

### **3.3.3 Solar Irradiance Measurement**

Sunlight is the only input for a solar PV system. To study a solar PV system, we need both the output and the input data of the PV system. We have already discussed that the output power of a solar PV system fluctuates. In order to study the fluctuations of the output of the PV system, the time resolution of the solar insolation data is very important and should be matched with the time resolution of the output data [22].

The deterministic component of solar irradiance defined by daily, monthly or yearly climate at a certain location can be estimated. Whereas the stochastic component that is the reason of the fluctuations of deterministic component of solar irradiation is defined by daily weather. To

estimate the output energy of a PV system over a particular time period, hourly irradiance data can be used [25]. For a better estimation we should take short-term time period or sub-hourly data to obtain the power variation for different type of clouds as the voltage and current fluctuates due to clouds that has a significant effect on the system efficiency [23]. In that case, the irradiance measurement becomes more critical, however the high time resolution of the irradiance data will be helpful to predict the efficiency of the system more precisely.

### **3.4 Impact on Transmission Network**

We have discussed that the generated power from a solar PV may fluctuate over the day. As a result, the transmission line network may be affected by the PV system, if the size of PV system is large enough. The fluctuating power becomes the major reason which affects the transmission network [26].

Jewell et al. have found that power swings in lines, power reversal, over or under loading in some lines, and extreme voltage fluctuations mainly occur due to frequently power fluctuations [26].

Tan et al. have observed the voltage level and stability of transmission network after fault conditions [27]. The results have shown that PV units affects the voltage level of the transmission network and the rotor of connected conventional generators are affected due to the PV system after a fault occurs [27].

It may be possible that the transmission line is affected by the PV system but proper isolation units can solve these issues by isolating the PV system from the network in any extreme situation.

### **3.5 Impact on Distribution Network**

Recently, the use of distributed solar PV system has significantly increased. The impacts of PV systems on the distribution networks are one of the most addressing issues to the utility companies. The impact of PV systems on distribution networks mainly depend on the size of the PV system. Small size roof top PV systems are very much common that is usually connected with the distributed load to decrease the energy consumption from the grid. Again,

when the size of the PV system becomes large enough, it is possible that the distribution network may be affected by the PV system.

Power conditioning units used in PV system is responsible for introducing the harmonic distortion [28], [29]. Research shows that the introduced harmonic distortions are usually below the limits defined by the standards [28], [29]. The advanced inverter technology is now able to control the harmonic distortions, however, when a large number of solar PV systems are installed in neighbors, the filter capacitors and inductors used in interfacing inverters might be in resonance with the electric network [30], [31].

From the above discussion we can summarize that when PV systems are used on a distribution network, the main concerns should be the size of solar PV system. Another situation should be taken in concern that if the cumulative capacity of the PV systems installed in a particular area is large enough, the distribution network might be affected by the PV systems.

### **3.6 Financial Impact**

The price of energy from solar PV in Bangladesh is still higher than that of energy from grid connection. However, the cost is rapidly decreasing due to advanced technology. Germany, Sweden, Italy, France, Australia, Chile, Jordan, 19 states of India and some other countries have already achieved the grid parity [1]. Morocco, Mexico and few other countries are very close to see the grid parity on solar PV [1]. We know that after achieving the grid parity, the cost of energy from solar PV will be the same or cheaper than the energy from the conventional sources. Simultaneously, the solar PV will eliminate the environmental issues associated with typical power plants without any extra expenses.

Distributed type grid-tied solar PV systems that are used for supplying to a particular load for reducing the peak energy demand from the grid have large financial advantages. Though installation cost of a residential PV system has declined recently, still it requires a significant investment from the owner. Maintenance cost of a solar PV system is minimal as it requires only periodic cleaning and grid-tied PV system may require replacement of the inverters after around 15 years of installation [32]. Installation of solar PV system along with the grid connection has several advantages as the owner uses self-owned generation unit for electricity production. The utility bill will be lower and the peak demand for the utility will be lower that improves the load factor. As a PV system can last for 30 years or more, it can provide long

term protection against rising electricity rates. In some countries where net metering is available, owner is paid back for the extra energy generation by the residential PV system that goes to the grid [32], [33].

Although a mid-size or large-size grid-tied PV system requires significantly high initial cost, it takes around 5-6 years to pay back the installation cost [34]. As a PV system requires a very low maintenance cost, once the installation cost is recovered, the cost of energy generation from the PV system will be much lower than that of energy from conventional generation system.

## CHAPTER 4

# PERFORMANCE ANALYSIS

### 4.1 Introduction

In this chapter we will analyze the performance of the selected grid-tied solar PV system. We will use the collected output data for the month of December 2017. The input solar estimation process will be discussed and the efficiency of the PV system will be estimated after considering self-shadowing effect and the sky clearness effect. Some performance matrices will also be calculated to get a better estimation of the performance of the PV system. A proposal will also be added to increase the efficiency of the PV system.

### 4.2 System Specifications

We have selected to analyze the performance of a roof top fixed 200kWp grid tied solar PV plant located at the Bangladesh Bureau of Statistics, Agargaon, Dhaka. A total of 670 solar panels each with capacity of 300Wp are used in this system that are made by EverExceed Industrial Co. Ltd., Germany. 12 inverters are used that are made by SMA Solar Technology AG, Germany. AC. The technical specifications of solar panel and inverter are shown in table 4.1 and table 4.2 respectively.

Table 4.1: Specification of ESM300 300Wp solar panel [35]:

<b>Construction &amp; General Characteristics</b>		
Model	ESM300	
Manufacturer	EverExceed Industrial Co. Ltd.	
Cell Material	Polycrystalline Silicon	
Dimensions	Length (mm)	1956
	Width (mm)	992
	Hight (mm)	45

<b>Electrical Parameters at Standard Test Conditions (STC)</b>	
Maximum Output Power	300W
Output Power Tolerances	0 ~ +5%
Module Efficiency	15.4%
Voltage at Maximum Power	36.2 V
Current at Maximum Power	8.28 A
Open-Circuit Voltage	44.9 V
Short-Circuit Current	8.85 A
<b>Electrical Parameters at Nominal Operating Cell Temperature (NOCT)</b>	
Output Power	241 W
Voltage at Maximum Power	37.0 V
Current at Maximum Power	6.53 A
Open-Circuit Voltage	45.0 V
Short-Circuit Current	7.06 A
<b>Operating Conditions</b>	
Maximum System Voltage	1000V (DC)
Maximum Series Fuse Rating	15 A
Operating Temperature Range	-40°C ~ 85°C

Table 4.2: Technical specification of SUNNY TRIPOWER STP 17000TL-10 inverter [36]:

<b>General Data</b>		
Model	STP 17000TL-10	
Manufacturer	SMA Solar Technology AG	
Dimensions	Width (mm)	665
	Height (mm)	690
	Depth (mm)	265
Operating Temperature Range	-25°C to 60°C	
Typical Noise Emission	51 dB	
Power Loss in Night Mode	< 1 W	
Cooling Method	SMA OptiCool	
Maximum Efficiency	98.2%	

DC Connection	SUNCLIX DC Connector	
AC Connection	Spring-Cage Terminal	
<b>DC Input</b>		
Maximum DC Power	17,410 W	
Maximum Input Voltage	1000 V	
MPP Voltage Range	400 V to 800 V	
Rated Input Voltage	600 V	
Minimum Input Voltage	150 V	
Maximum Input Current	Input Terminal A	33 A
	Input Terminal B	11 A
Maximum Short-Circuit Current	Input Terminal A	50 A
	Input Terminal B	17 A
Number of MPPT Inputs	2	
Strings per MPP Input	Input Terminal A	5
	Input Terminal B	1
<b>AC Output</b>		
Rated Power at 230 V, 50 Hz	17000 W	
Maximum Apparent AC Power	17000 VA	
Rated Grid Voltage	~3/N/PE, 230V/400V	
Nominal AC Voltage	220 V, 230 V, 400 V	
AC Voltage Range	160 V to 280 V	
Maximum Output Current	24.6 A	
Harmonic Distortion	≤ 2.6%	
Inrush Current	< 20% of the Nominal AC Current for 10 ms	
Maximum Fault Current	0.05 kA	
AC Power Frequency	50 HZ / 60 Hz	
Feed-in & Connection Phases	3	
<b>Protective Devices</b>		
DC Reverse Polarity	Short-Circuit Diode, Electric Fuse (Maximum 50A)	
Reverse Current	Electronic String Fuse	
Input-Side Disconnection Point	Electronic Solar Switch, SUNCLIX DC Connector	



DC Overvoltage Protection	Surge Arresters Type II
Grid Monitoring	SMA Grid Ground 4
Ground Fault Monitoring	Insulation Monitoring: $R_{iso} > 323.4 \text{ k}\Omega$

Figure 4.1 shows the connection block diagram of the whole PV system.

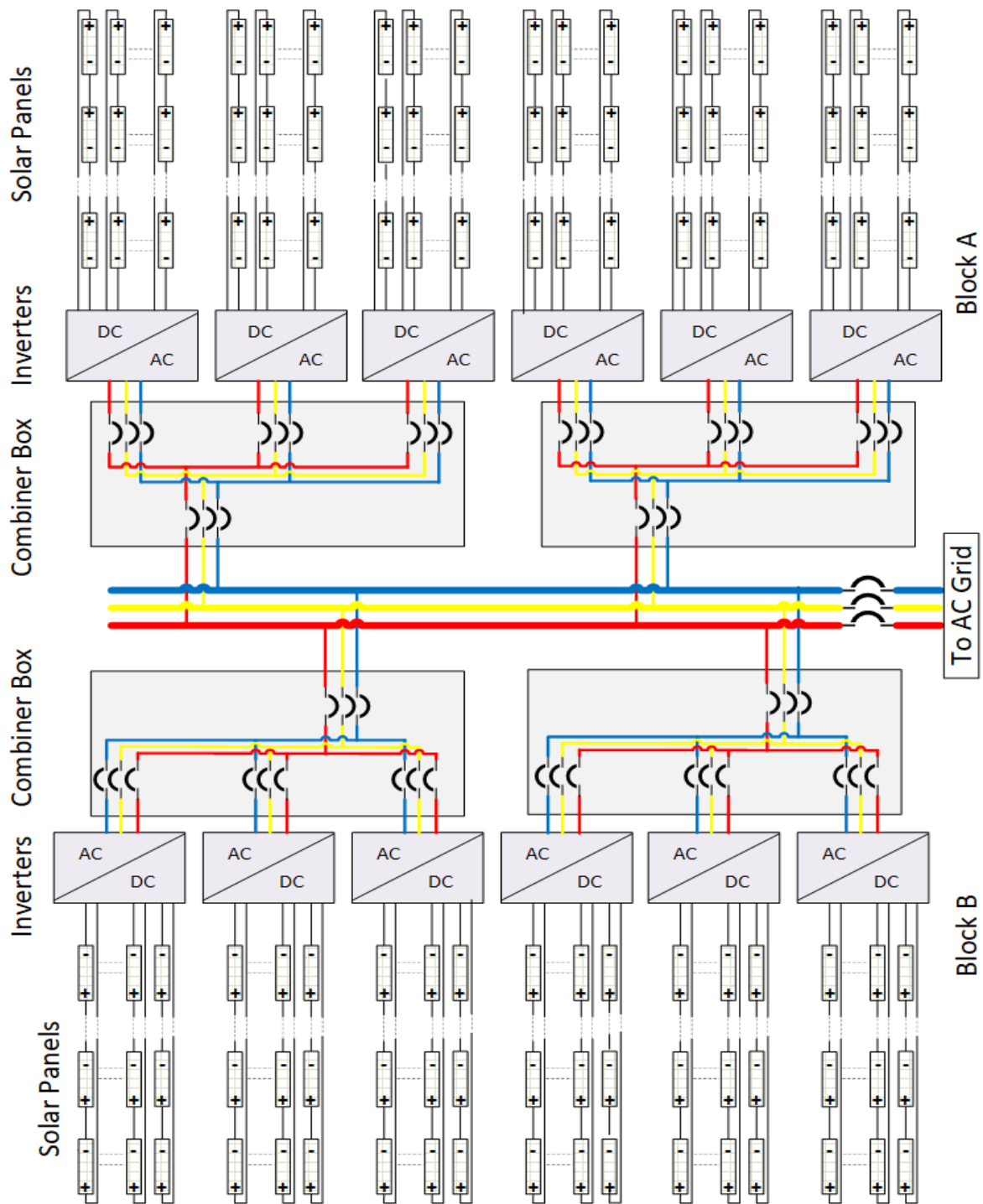

Figure 4.1: Block diagram of the whole PV system.

The system is divided into two blocks. Both blocks are symmetrical in connection. Each block consists of 335 solar panels that are directly connected with 6 inverters as the inverters have internal charge conditioning unit with MPPT. The outputs of the inverters are combined in combiner boxes using bus-bar and protective circuit breakers. In case of any inverter failure or maintenance, we can isolate the particular inverter from the system using the circuit breakers that are used in the combiner box. The outputs from the combiner boxes go to another central combining unit. Central combiner unit combines the whole PV system and has an energy meter that shows the power, voltage, current and energy in real time. This central combining unit is directly interfaced with the grid connection. The line to line voltage is 400V in three-phase connection. The energy meter measures and displays the energy that is supplied to the grid by the PV system.

Figure 4.2 shows the actual connections inside the combiner boxes.

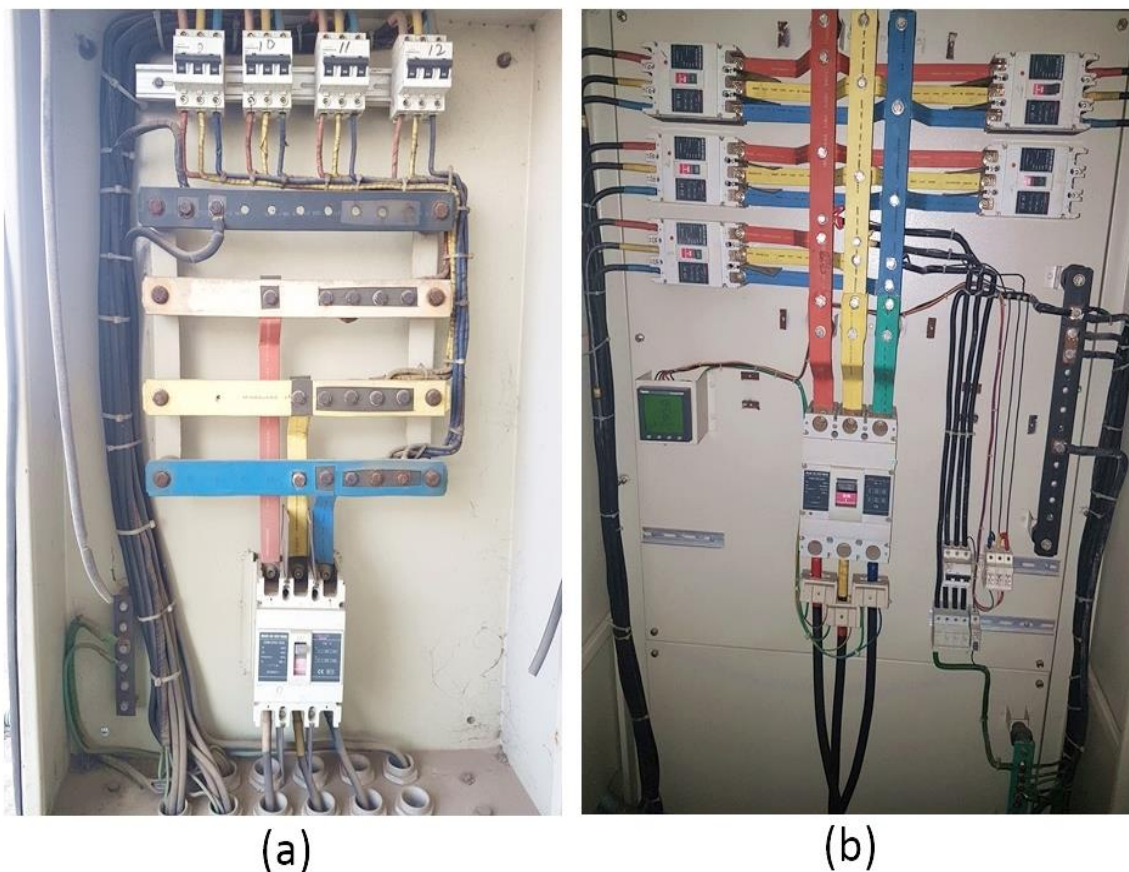

Figure 4.2: (a) Combiner box that combines the inverters, (b) central combiner box that interfaces the PV system with grid connection.

### 4.3 Performance Matrices

Some performance parameters are used to estimate the efficiency of a grid-tied PV system. In this section we will briefly explain some parameters such as final yield, reference field, system efficiency, performance ratio, and capacity factor that are used for estimating the performance of a PV system.

#### 4.3.1 Final Yield

Final yield [6] is defined as the ratio of net daily, monthly or annual AC energy output of the PV system and the rated power of that PV system. It can be expressed as equation 4.1.

$$Y_f = \frac{E_{AC,d}}{P_{PV_{rated}}} \dots \dots \dots (4.1)$$

Where,  $E_{AC,d}$  is daily AC output energy and  $P_{PV_{rated}}$  is the rated power of the PV plant.

#### 4.3.2 Reference Yield

Reference yield [6] is defined as the ratio of total daily in-plane solar irradiation and the reference irradiation. It simply represents the number of peak sun-hours per day [h/d]. Equation 4.2 can be used to obtain the reference yield or peak sun hour.

$$Y_r = \frac{H_t [kWh/m^2]}{G_{i-ref} [kW/m^2]} \dots \dots \dots (4.2)$$

Where,  $H_t$  is the daily solar irradiance per unit area to the collector and  $G_{i-ref}$  is the reference irradiance per unit area.

#### 4.3.3 Performance Ratio

Performance ratio is a dimensionless quantity that refers to the overall effect of different losses on the rated output due to PV module temperature, inverter efficiency, wiring mismatch, soiling and component failure. It is basically a location-oriented term and it actually does not represent the amount of energy production.

Performance ratio [6] is defined as the ratio of the energy injected to the grid (final yield) and the energy that the system could have produced at its DC rated power for the number of peak sun hours per day (reference yield). It can be determined using the equation 4.3.

$$PR = \frac{Y_f}{Y_r} \dots \dots \dots (4.3)$$

Here,  $Y_f$  is the final yield and  $Y_r$  is the reference yield.

#### 4.3.4 Capacity Factor

The capacity utilization factor or simply capacity factor is defined by the ratio of actual energy generation by the PV system to the energy that could have been produced if the system is operated at its full rated power for 24h per day for a given time period or usually for a whole year [6]. We can calculate the capacity factor of a PV system using equation 4.4.

$$CUF = \frac{E_{AC-a}}{P_{PV\,rated} \times 8760} \times 100\% \dots \dots \dots (4.4)$$

Here,  $E_{AC-a}$  is the actual annual energy production from the solar PV system.

#### 4.4 Solar Irradiance Calculation

To estimate the input energy, we need to calculate the solar irradiance on the collector. For this purpose, we have followed the model given by Masters [5]. Solar irradiance has three components – direct beam, diffusion, reflected. The reflected radiation is very small in fraction comparing to the other two components. So, we can ignore the reflected component and can analytically calculate the solar irradiance using direct beam component and diffusion component.

Total insolation on a tilted collector ignoring reflected component can be expressed as shown in equation 4.5.

$$I_C = I_{BC} + I_{DC} \dots \dots \dots (4.5)$$

Here,  $I_C$  is the irradiance to the collector,  $I_{BC}$  is the direct beam radiation, and  $I_{DC}$  is the diffuse radiation to the collector.

The beam radiation on a tilted collector is provided by equation 4.6.

$$I_{BC} = I_B \cos \theta \dots \dots \dots (4.6)$$

Here,  $I_B$  beam radiation at earth's surface and  $\theta$  is the incidence angle to the collector.

Equation 4.7 represents the clear sky earth surface beam radiation at the earth's surface.

$$I_B = A e^{-k.m} \dots \dots \dots (4.7)$$

Here,  $A$  is apparent extraterrestrial solar insolation,  $k$  is atmospheric optical depth, and  $m$  is the air mass ratio.

Atmospheric optical depth and extraterrestrial solar insolation for  $n^{\text{th}}$  day of the year are defined by as follows in equation 4.8 and equation 4.9 respectively.

$$k = 0.174 + 0.035 \sin \left[ \frac{360}{365} (n - 100) \right] \dots \dots \dots (4.8)$$

$$A = 1160 + 75 \sin \left[ \frac{360}{365} (n - 275) \right] \dots \dots \dots (4.9)$$

Air mass can be calculated using equation 4.10.

$$m = \frac{1}{\sin \beta} \dots \dots \dots (4.10)$$

Here,  $\beta$  is the sun elevation or solar altitude angle and it is defined by the equation 4.11.

$$\beta = 90^\circ - \text{Zenith Angle} \dots \dots \dots (4.11)$$

The cosine of the incidence angle on a tilted surface can be obtained using the angles like sun elevation, surface azimuth, collector azimuth, and collector tilt as shown in equation 4.12.

$$\cos \theta = \cos \beta \cos(\phi_s - \phi_c) \sin \Sigma + \sin \beta \cos \Sigma \dots \dots \dots (4.12)$$

Here,  $\phi_s$  is the solar azimuth angle,  $\phi_c$  is the collector azimuth angle, and  $\Sigma$  is the tilt angle of the collector.

Again, diffusion component on the collector can be estimated using equation 4.13.

$$I_{DC} = I_{DH} \left( \frac{1 + \cos \Sigma}{2} \right) \dots \dots \dots (4.13)$$

Here,  $I_{DH}$  is the diffuse insolation on a horizontal surface that can be calculated by equation 4.14.

$$I_{DH} = C \cdot I_B \dots \dots \dots (4.14)$$

Here,  $C$  is the sky diffusion factor that can be calculated for  $n^{\text{th}}$  day of the year using equation 4.15.

$$C = 0.095 + 0.04 \sin \left[ \frac{360}{365} (n - 100) \right] \dots \dots \dots (4.15)$$

The zenith and solar azimuth angle will be collected hourly from online database [37].

#### 4.5 Clearness Index Calculation

Sky clearness index is defined by the ratio of the average horizontal insolation at a site and the average extraterrestrial insolation on a horizontal surface above the site. It can be calculated using equation 4.16 [5].

$$K_T = \frac{\bar{I}_H}{\bar{I}_0} \dots \dots \dots (4.16)$$

Here,  $\bar{I}_H$  is the monthly average horizontal insolation at the site and  $\bar{I}_0$  is the monthly average extraterrestrial insolation on a horizontal surface above the site just above the atmosphere.

The average horizontal insolation at the particular site will be collected from online database [38]. The extraterrestrial insolation for  $n^{\text{th}}$  day of the year on a horizontal surface above the site can be estimated by equation 4.17.

$$\bar{I}_0 = \left( \frac{24}{\pi} \right) (SC) \left[ 1 + 0.034 \cos \left( \frac{360n}{365} \right) \right] (\cos L \cos \delta \sin H_{SR} + H_{SR} \sin L \sin \delta) \dots \dots (4.17)$$

Here,  $SC$  refers to the solar constant,  $L$  is latitude of the site,  $\delta$  sun declination angle, and  $H_{SR}$  is the sunrise hour angle.

The sun declination angle for  $n^{\text{th}}$  day of the year and sunrise hour angle can be calculated using equation 4.18 and equation 4.19 respectively.

$$\delta = 23.45 \sin \left[ \frac{360}{365} (n - 81) \right] \dots \dots \dots (4.18)$$

$$H_{SR} = \cos^{-1}(-\tan L \tan \delta) \dots \dots \dots (4.19)$$

#### 4.6 Solar Insolation Considering Clearness Index

The total insolation after considering the clearness index can be estimated by following the models given by Masters [5]. If we ignore the reflected component of the solar irradiance then the total insolation striking the collector after considering clearness index can be estimated using equation 4.20.

$$\bar{I}_C = \bar{I}_H \left(1 - \frac{\bar{I}_{DH}}{\bar{I}_H}\right) \cdot R_B + \bar{I}_{DH} \left(\frac{1 + \cos \Sigma}{2}\right) \dots \dots \dots (4.20)$$

Here,  $\bar{I}_H$  is the total horizontal insolation,  $\bar{I}_{DH}$  is the diffuse portion of the insolation, and  $R_B$  average beam tilt factor. Here, the ratio of diffuse portion of the insolation to the total horizontal insolation will be calculated by correlating the clearness index [5].

The beam tilt factor can be estimated by equation 4.21.

$$R_B = \frac{\cos(L - \Sigma) \cos \delta \sin H_{SRC} + H_{SRC} \sin(L - \Sigma) \sin \delta}{\cos L \cos \delta \sin H_{SR} + H_{SR} \sin L \sin \delta} \dots \dots \dots (4.21)$$

Here,  $H_{SRC}$  is the sunrise hour angle for the collector when the sunlight first strikes the collector and  $H_{SR}$  is the sunrise hour angle.

To correlate clearness index Masters has followed the Liu and Jordan correlation equation shown in equation 4.22.

$$\frac{\bar{I}_{DH}}{\bar{I}_H} = 1.390 - 4.027K_T + 5.531K_T^2 - 3.108K_T^3 \dots \dots \dots (4.22)$$

Here,  $K_T$  is the clearness index.

The sunrise hour angle for the collector which means when the sunlight first strikes the collector face can be obtained by equation 4.23.

$$H_{SRC} = \min\{\cos^{-1}(-\tan L \tan \delta), \cos^{-1}[-\tan(L - \Sigma) \tan \delta]\} \dots \dots \dots (4.23)$$

#### 4.7 Analysis of Collected Data

We have collected the AC output voltage, current, power, and energy readings from the selected PV system for the month of December 2017. We have collected the real time data from the energy meter provided in the central combiner box that interfaces the PV system with grid connection. We will analytically calculate the solar insolation and the clearness index to assess the performance of the PV plant.

We have data for the time period of 9 AM to 5 PM during the weekdays. To obtain the energy for a whole day we have extrapolated the power vs. time curve and integrated the fitted curve to calculate the area that represents the energy not included between 9 AM to 5 PM.

At first, we have taken a sample day with maximum number of output data available. Then, we have plotted the power vs. time curve in MATLAB and fitted the polynomial curve on that power vs. time curve. We have used the trapezoidal rule to calculate the area of the fitted curve [39]. Then, we have separately calculated the energy from sunrise to 9 AM and from 9 AM to evening. Then, we estimated the ratio of these two energies to estimate the energy fraction from sunrise to 9 AM. Figure 4.3 shows the plot of power vs. time.

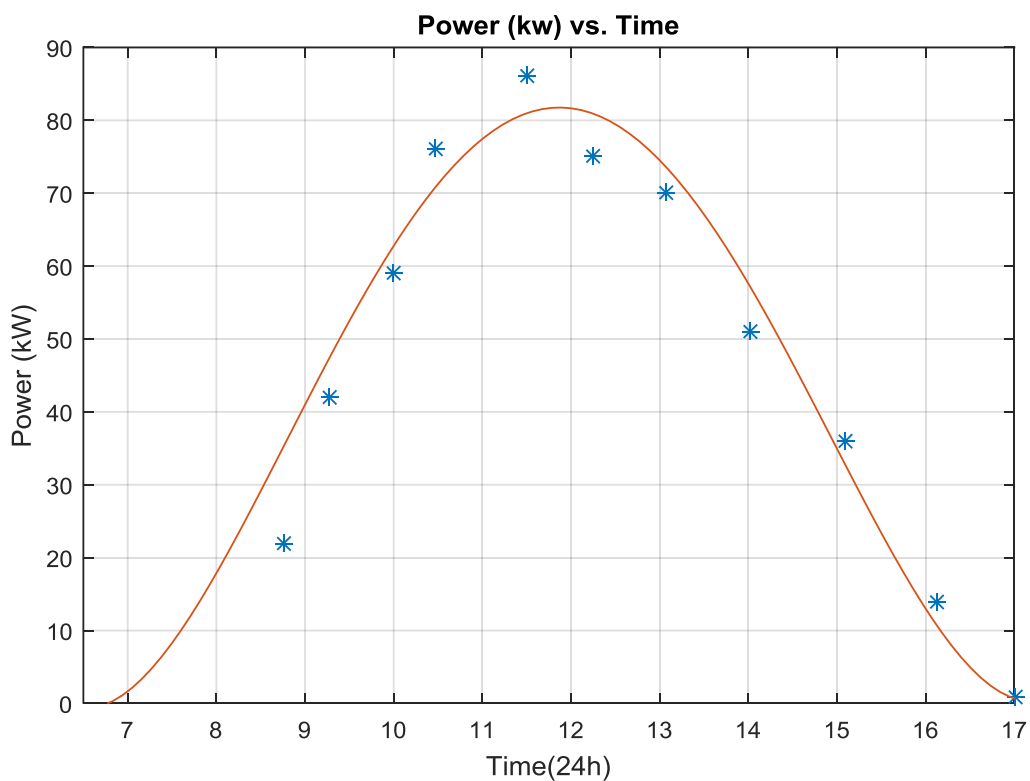

Figure 4.3: Power vs. time curve with polynomial fitting for December 3, 2017.



Now, if ‘ $\alpha$ ’ is the ratio of those energies, then we can estimate the daily output energy as  $(1+\alpha)$  times the energy from 9 AM to evening.

To estimate the value of ‘ $\alpha$ ’, we have chosen 3 days in the observation time with a maximum number of output data available. Table 4.3 shows the estimation of ‘ $\alpha$ ’.

Table 4.3: Estimation of ‘ $\alpha$ ’.

Date	Collected energy from 9 AM to 5 PM, E (kWh)	Daily energy after polynomial fitting (kWh)	Energy from sunrise to 9 AM, $E_m$ (kWh)	Energy from 9 AM to evening, $E_d$ (kWh)	$\alpha = E_m/E_d$	Total daily energy, $(1+\alpha).E$ (kWh)	Error between fitted and calculated energy (%)
03-12-17	405.48	463.43	49.06	414.38	0.118	453.32	2.1
12-12-17	428.97	469.63	27.97	441.65	0.063	455.99	2.9
27-12-17	372.56	418.89	35.99	382.90	0.094	407.58	2.7

From table 4.3 we have observed that for the values of  $\alpha = 0.118$ ; 0.063 and 0.094, error between calculated energies and the energies obtained from polynomial fitting is less than 3% which is acceptable. Therefore, an average value of  $\alpha = 0.1$  can be used to calculate the daily output energies of the PV system for the observation period.

To estimate the input energy, we have followed the models provided by Masters that is explained in section 4.4 of this chapter. At first, we have theoretically calculated the hourly solar insolation on the collector and then integrated power with time to obtain the daily in plane solar insolation.

We have also observed the shadowing effect of the PV system. Figure 4.4 shows the shadowing due to building and figure 4.5 shows the self-shadowing at different times of a day for better understanding.

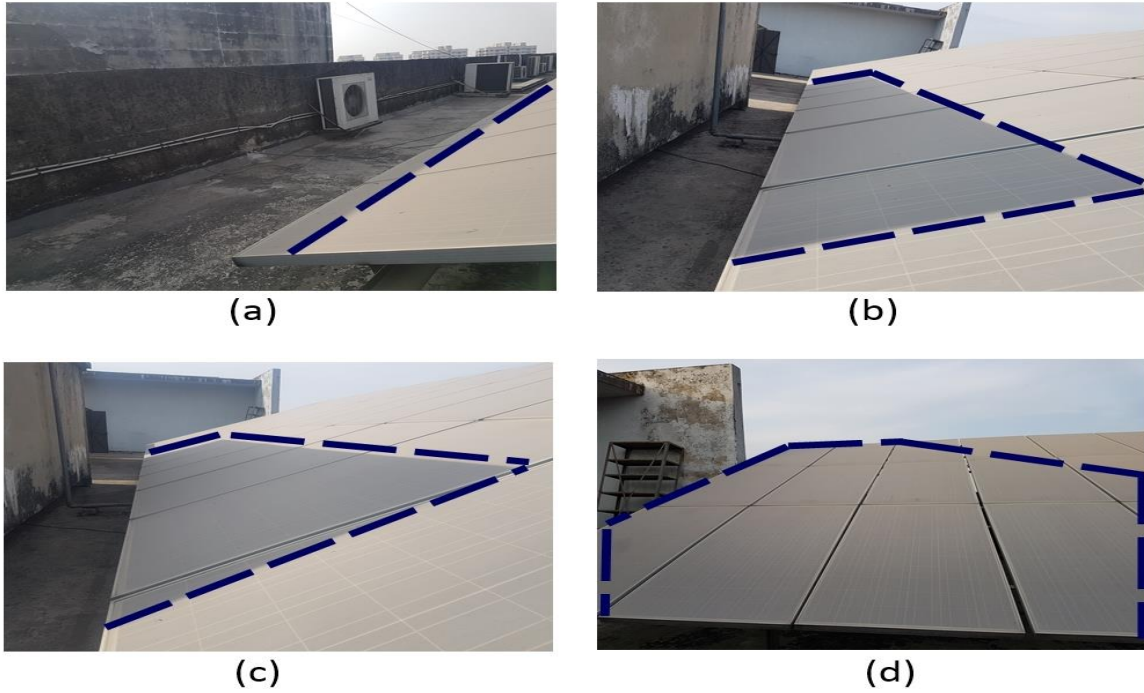

Figure 4.4: Shadowing due to building at – (a) 1 PM – 2 PM, (b) 2 PM – 3 PM, (c) 3 PM – 4 PM, (d) 4 PM – 5 PM.

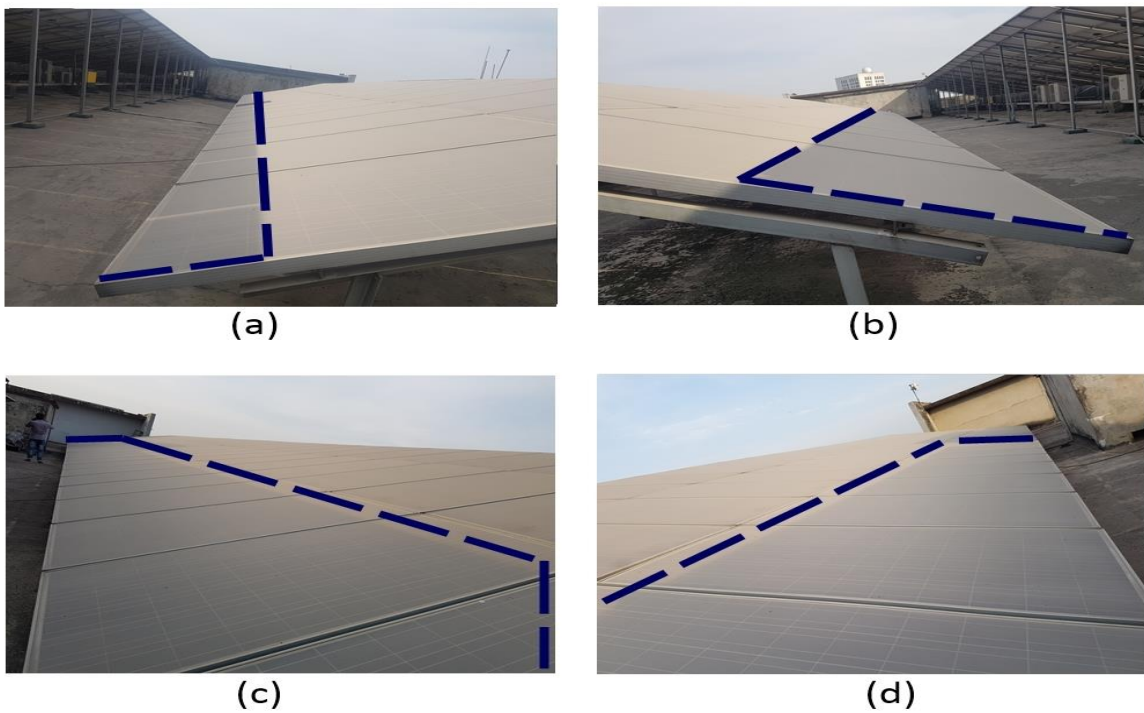

Figure 4.5: Self-shadowing at – (a) 1 PM – 2 PM, (b) 2 PM – 3 PM, (c) 3 PM – 4 PM, (d) 4 PM – 5 PM.

After a day of observation, we have observed that shadowing of the panels starts after 12:30 PM. We have observed both the shadowing effect for the building and the array structures. We have recorded percentage of shaded area of panels from 1 PM to 5 PM at one-hour interval. We have normalized the amount of shadowing of the panels. Numbers of shaded panels in different time periods of the day are given in table 4.4.

Table 4.4: Number of shaded panels due to self-shadowing and building.

Time Period	Shaded panels in percentage		Equivalent Number of shaded panels
	No. of Panels	Shaded area in each panel (%)	
01:00 PM to 02:00 PM	96	5	4.8
02:00 PM to 03:00 PM	12	25	34.8
	14	20	
	71	15	
03:00 PM to 04:00 PM	12	75	130.25
	44	70	
	54	65	
	51	55	
	44	40	
	30	15	
	52	10	
04:00 PM to 05:00 PM	40	100	149.5
	54	95	
	27	80	
	20	70	
	20	50	
	37	20	
	52	10	

The input energy to the PV system is calculated after considering these shadowing effect as the shaded panels get only the diffusion component of the sunlight, whereas the major energy component of the sunlight is the direct beam component.

Next, we have calculated the sky clearness index analytically to get the actual input energy to the PV system. For these purpose, we have collected the monthly average terrestrial horizontal insolation from online database [39]. Then we have calculated the extraterrestrial insolation using the models provided by Masters as explained in section 4.5. Finally, we have obtained the clearness index using that information. We have gotten a clearness index of 0.625 for the month of December 2017, whereas the clearness index in Bangladesh for that month is typically 0.5 to 0.6 [40]. Therefore, this value of clearness index can be approximately used to calculate the actual in plane solar irradiance to the collector.

Table 4.5 shows the input irradiance, input irradiance considering the shadowing effect, input irradiance considering the clearness index, input irradiance considering both shadowing and clearness index, output energy of the PV system for the observation period.

Table 4.5: Input and output energies of the PV system.

Date	Daily Input Energy (kWh)	Daily Input Energy Considering Shadowing (kWh)	Energy Considering Clearness Index (kWh)	Daily Input Energy Considering Shadowing & Clearness Index (kWh)	Daily Output Energy (kWh)
03-12-17	7110.7	6911.7	4984.6	4785.6	445.7
04-12-17	7095.6	6717.9	4964.3	4586.6	387.9
05-12-17	7076.9	6883.1	4962.8	4768.9	419.2
06-12-17	7071.7	6608.8	4927.0	4464.1	383.6
07-12-17	7089.8	6885.0	4931.5	4726.7	427.2
10-12-17	7065.4	6742.6	4887.7	4564.9	112.5
11-12-17	7046.3	6672.4	4872.3	4498.4	94.5
12-12-17	7056.6	6855.6	4868.9	4667.9	471.9

13-12-17	7047.5	6823.2	4823.2	4631.3	391.6
14-12-17	7050.8	6841.0	4853.5	4643.7	450.2
17-12-17	7466.6	7085.3	5541.7	5160.4	352.4
18-12-17	7018.9	6821.7	4815.6	4618.4	364.3
19-12-17	7014.7	6820.9	4811.6	4617.8	180.9
20-12-17	7010.5	6800.0	4805.9	4595.4	277.6
21-12-17	6977.2	6755.4	4790.1	4568.3	291.9
24-12-17	7025.3	6799.2	4816.5	4590.4	302.2
26-12-17	7031.5	6808.0	4825.2	4601.7	373.3
27-12-17	7023.9	6822.7	4823.2	4621.9	409.8
28-12-17	7042.9	6810.5	4840.2	4607.7	401.5
31-12-17	7066.5	6876.8	4876.3	4681.6	454.0
Average	7069.5	6817.1	4902.5	4650.1	349.6

Table 4.6 shows the daily efficiencies considering shadowing and clearness index separately and both at the same time.

Table 4.6: Efficiencies of the PV system considering clearness index and shadowing.

Date	System Efficiency (%)			
	Without Considering Shadowing & Clearness Index	Considering Shadowing	Considering Clearness Index	Considering Clearness Index & Shadowing
03-12-17	6.27	6.45	8.94	9.31
04-12-17	5.46	5.77	7.80	8.45
05-12-17	5.92	6.09	8.45	8.79
06-12-17	5.42	5.80	7.79	8.53
07-12-17	6.03	6.21	8.66	9.04
10-12-17	1.59	1.67	2.30	2.46
11-12-17	1.34	1.42	1.94	2.10
12-12-17	6.69	6.88	9.69	10.11
13-12-17	5.56	5.74	8.06	8.46
14-12-17	6.39	6.58	9.28	9.69

17-12-17	4.72	4.97	6.36	6.83
18-12-17	5.19	5.34	7.57	7.89
19-12-17	2.58	2.65	3.76	3.92
20-12-17	3.96	4.08	5.78	6.04
21-12-17	4.18	4.32	6.09	6.39
24-12-17	4.30	4.44	6.27	6.58
26-12-17	5.31	5.48	7.74	8.11
27-12-17	5.83	6.01	8.49	8.87
28-12-17	5.70	5.89	8.29	8.72
31-12-17	6.43	6.60	9.32	9.69
Average	4.94	5.12	7.13	7.50

From table 4.6 we have observed that the PV system has efficiency between 4-6% without considering the clearness index and around 6-9% after considering the clearness index. Considering the shadowing effect and clearness index separately the monthly average efficiency of the PV system is 5.12% and 7.13% respectively. When we have considered both shadowing effect and clearness index, monthly average 7.50% of overall system efficiency is delivered by the PV system. The maximum efficiency of the system is 10.11% at 12<sup>th</sup> December. There was drizzle on December 10<sup>th</sup> and 11<sup>th</sup>.

#### **4.8 Investigation of System Performance**

In section 4.7 of this chapter, we have observed that the PV system has 7.5023% of monthly average overall efficiency after considering both clearness index and shadowing effect.

Clear sky solar irradiance, solar irradiance after considering shadowing only, clearness index only, both shadowing and clearness index, and output energies are shown in figure 4.6. Figure 4.7 shows the overall efficiency of the PV system for those scenarios.

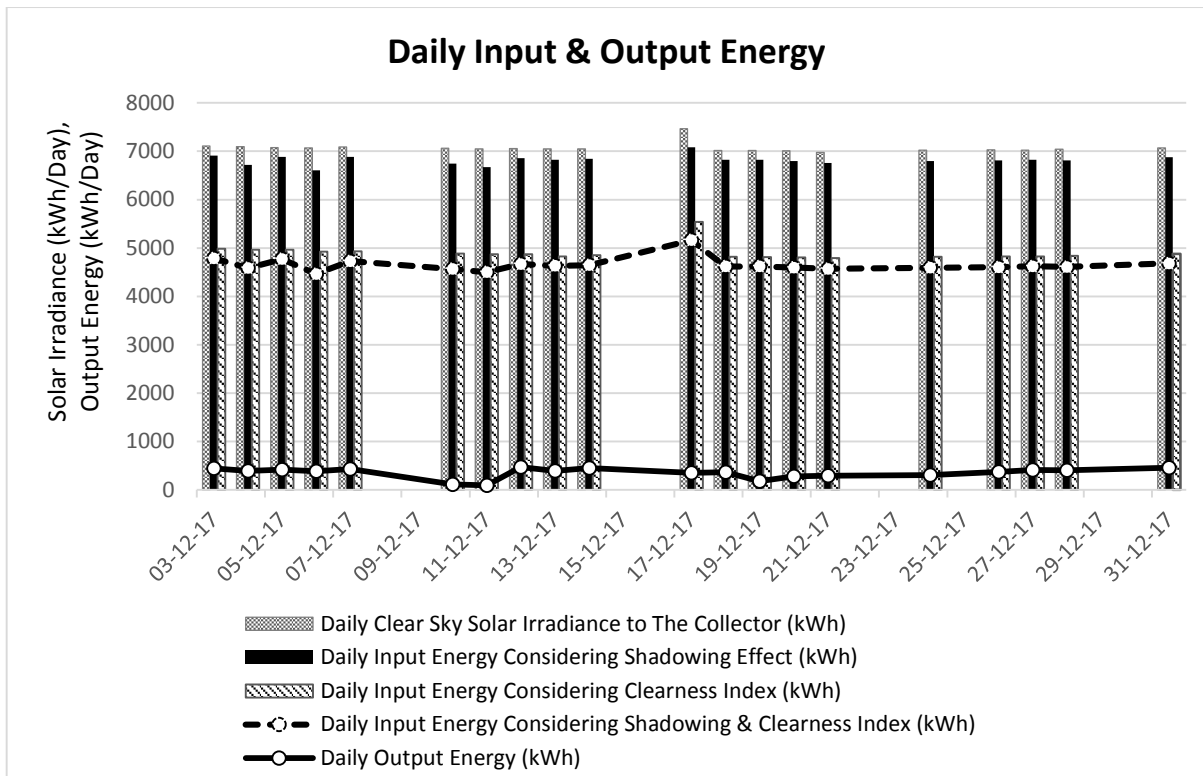

Figure 4.6: Daily input and output energies of the PV system.

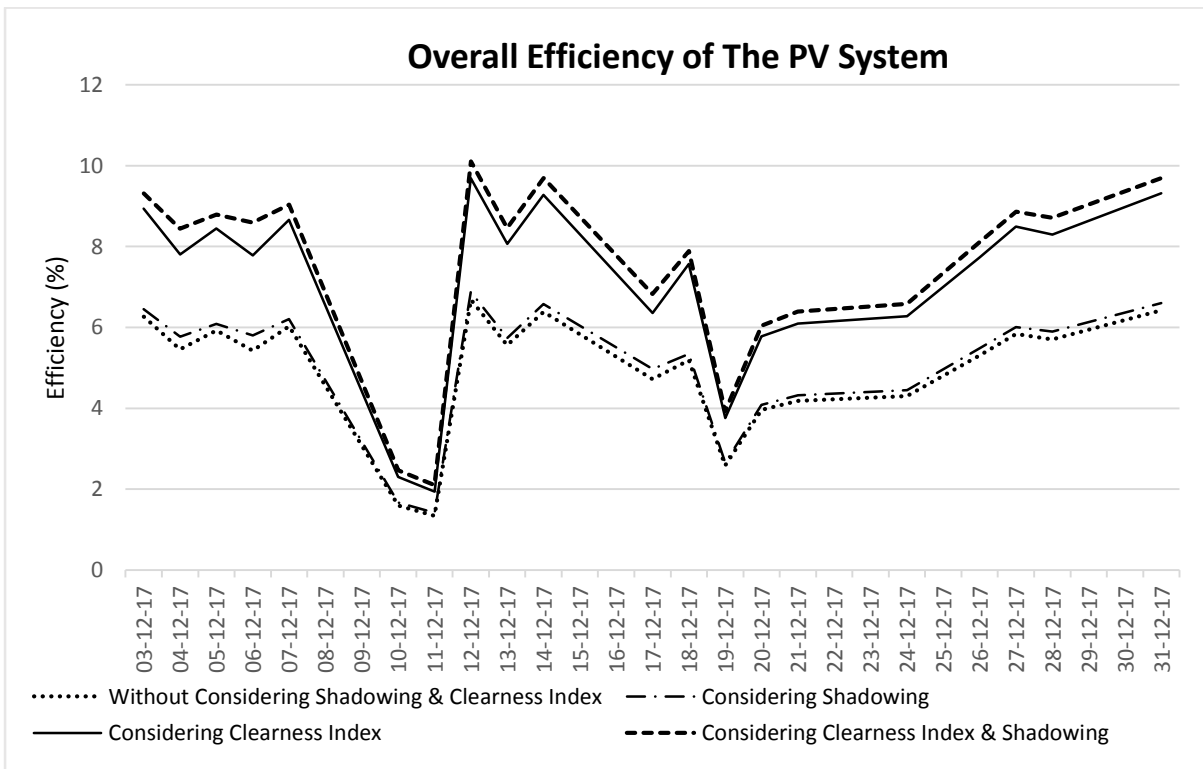

Figure 4.7: Overall efficiency of the PV system.

We have observed that the shadowing effect has an insignificant effect on the system efficiency. However, the clearness index has a significant effect on the system efficiency. We have some extreme cases in observation period when the output became very low due to rain on 10<sup>th</sup> and 11<sup>th</sup> December and extreme foggy weather during the 3<sup>rd</sup> week of the month. Monthly average overall system efficiency of 5.12%, 7.13%, and 7.50% were obtained for considering only shadowing effect, only clearness index, and both shadowing and clearness index respectively.

The PV modules used in this PV system have a maximum efficiency of 15.4% [35] and the inverters have a maximum efficiency of 98% [36]. In that case, the system has a maximum theoretical overall system efficiency of 15.1%. From table 4.6 we have observed that daily overall system efficiencies as well as the monthly average overall efficiency of the PV system are much lower than the theoretical maximum efficiency of the PV system. We have observed that the PV system exhibits a maximum of 10.11% of daily overall system efficiency after a rainy day with considering clearness index and shadowing effect. In all these situations, dirt loss is not considered. Consequently, it is possible to get higher overall system efficiency from this PV system if dirt loss can be reduced.

According to the analyzation of system efficiency for different situations, we can say that the efficiency of the PV system is not satisfactory. Further analyzation of some performance matrices is needed to estimate the performance of the PV system more accurately.

For these purpose, we have calculated some parameters such as final yield, reference yield, performance ratio and the capacity factor for this PV system. Table 4.5 contains the values of these parameters which will provide a better estimation of the performance of the PV system. Capacity factor of the PV system is calculated only for the observation period from December 3<sup>rd</sup> to December 31<sup>st</sup>. In these 29 days, the PV system has supplied a total of 9670.5 kWh energy to the grid.



Table 4.7: Values of performance matrices for the PV system.

<b>Date</b>	<b>Final Yield (h/day)</b>	<b>Reference Yield (h/day)</b>	<b>PR</b>	<b>Capacity Factor (%)</b>
03-12-17	2.23	4.16	0.54	6.9
04-12-17	1.94	4.15	0.47	
05-12-17	2.09	4.14	0.51	
06-12-17	1.92	4.14	0.46	
07-12-17	2.14	4.15	0.52	
10-12-17	0.56	4.13	0.14	
11-12-17	0.47	4.12	0.11	
12-12-17	2.36	4.13	0.57	
13-12-17	1.96	4.12	0.48	
14-12-17	2.25	4.12	0.55	
17-12-17	1.76	4.37	0.40	
18-12-17	1.83	4.10	0.44	
19-12-17	0.90	4.10	0.22	
20-12-17	1.39	4.09	0.34	
21-12-17	1.46	4.08	0.36	
24-12-17	1.51	4.10	0.37	
26-12-17	1.87	4.11	0.45	
27-12-17	2.05	4.10	0.49	
28-12-17	2.01	4.12	0.49	
31-12-17	2.27	4.13	0.55	
<b>Average</b>	<b>1.75</b>	<b>4.13</b>	<b>0.42</b>	

Here, we have observed that daily final yield for the PV system is less than 2.5 h/day. Daily final yield represents the time required for the PV system at its rated power condition to produce the same amount of energy that is produced in a whole day [6]. Therefore, a higher value of final yield represents more energy production from the PV system. We usually expect the value of daily final yield close to the peak sun hour. Because if the PV system operates in its rated condition for the time of peak sun hour, the maximum energy production is possible. We have observed monthly average 4.13 h/day of peak sun hour and average 1.75 h/day of daily final

yield for this PV system which is much lower than the average peak sun hour. Therefore, a huge amount of useable solar energy is still available that can be converted into electrical energy.

The monthly average reference yield or peak sun hour is 4.13 h/day which is reasonable for the month of December. The performance ratio is less than 0.6 and the monthly average performance ratio is 0.42, where a PV system may usually have a performance ratio from 0.6 to 0.8 depending on the location and the weather of that location [41].

Capacity factor of a PV system depends on geographical location and weather conditions. A higher capacity factor represents more energy production from the PV system. The capacity factor for roof top solar PV system in Indian sub-continent region is around 16-17% [42]. We have gotten a capacity factor of 6.9% for the observation period for this PV system, where it should be around 15%. Thus, the capacity factor of this PV system is unsatisfactory. A poor capacity factor means the system produces a much lower energy than the energy that could have been produced by the PV system.

After analyzing all the performance parameters and the overall efficiency, we can say that the performance of the PV system is not satisfactory. Necessary initiatives should be taken to improve the performance of the PV system.

#### **4.9 Proposal for Increasing the Performance**

From the above analyzation we have observed that the performance of the PV system was not satisfactory. The efficiency of the system can be improved by taking necessary initiatives. We know that in every solar PV system the panels need to be cleaned regularly. As far as we have known that the panels have not been cleaned for around 1 year. Figure 4.9 shows the panels during the observation time and figure 4.10 shows the close up of the panels to estimate the dirt condition on the panel.



Figure 4.8: PV panels of the system.



Figure 4.9: Close up of the panels of the PV system.

From the above figures we can see that a lot of dirt is present on all the panels of the PV system. To get a better estimation, we have cleaned half of a panel that is shown in figure 4.11.



Figure 4.10: Solar panel after cleaning.

Here we can easily observe that the amount of dirt is significantly high which degrades the performance of the PV system.

Some other reasons are also responsible for degrading the performance of the PV system too. One of the reasons is lack of monitoring the performance. The inverters have online database system to store and monitor the real time energy generation from the system. However, the facility is out of service for around 1 year. For this reason, the monitoring of individual inverters is not done as the system is large enough and located at the roof of a Govt. building where the entry is restricted. We have also known that the routine system checkup was not done by the company that installed the PV system.

Some necessary initiatives such as cleaning of the panels and monitoring of the system should be done to improve the performance of the PV system. To ensure a better performance and expected energy generation from a grid-tied PV system, we should follow some conditions and regular monitoring. A guideline is given below.

- The tilt angle for a fixed PV system should be chosen wisely as it affects the output of any PV system.
- Distance between the adjacent rows of panels should be sufficient to eliminate the self-shadowing.
- Location should be chosen wisely to avoid the shadowing due to any building structure.
- Although the inverters used in grid-tied PV system has a very high performance, the operation should be monitored regularly to ensure the optimal energy production.
- If online data is available then it should be recorded to make the monitoring of the system easier.
- If a system has combiner boxes then that boxes should be checked periodically and the connections should be made by bus bars. It is better to avoid simple wire connection inside any combiner box where circuit breakers are present.
- Voltage, power and frequency variations should be monitored in grid-tied PV system.
- The security measurements must be checked periodically.
- The periodic cleaning of the PV panels is much important to ensure that the PV modules get as much light as possible.

#### **4.10 Summary**

In this chapter we have provided the configuration of the system. The input irradiance is calculated with and without considering the clearness index. The daily energy generation was measured and the efficiency of the system has been calculated. Some performance matrices have been estimated and the result was not much satisfactory. Finally, a proposal to take some initiatives for improving the performance of the PV system is provided.

## CHAPTER 5

# CONCLUSION

### 5.1 Summary

We have analyzed the performance of a 200kWp grid-tied solar PV system. We have observed the energy production from the PV system for the month of December 2017. There were some extreme cases due to rain and heavy foggy weather when the output of the PV system became very low. Except for these extreme situations, the output of the PV system was not much satisfactory but moderate.

We have found that the monthly average overall efficiency of the PV system is 4.94% without considering clearness index or shadowing effect on the PV system. The monthly average overall efficiency of the PV system is 5.12% considering only the shadowing effect both for building and self-shadowing. Considering the clearness index, we have found that the monthly average overall efficiency is 7.13%. When we have considered both the clearness index and shadowing effect the monthly average overall efficiency is 7.50%. The PV system had the minimum overall efficiency of 2.10% on 11<sup>th</sup> December as there was drizzle on that day. After the drizzle, the PV system exhibited the maximum overall efficiency of 10.11%. The monthly average daily final yield is 1.75 h/day and the average peak sun hour for the observation period is 4.13 h/day. 6.9% of capacity factor is shown by the PV system for the observation period of December, 2017. The monthly average performance ratio was 0.42 for the PV system.

Analyzing all the performance matrices we can summarize that the performance of the PV system is not satisfactory and it can be increased. We have found that lack of maintenance and regular monitoring of the PV system are the main reasons that degrade the performance of the PV system. To increasing the performance of the PV system the steps that should be taken are explained in this work.

A brief guideline is provided for PV system to ensure the energy production from the system.

## 5.2 Future Work

In this work we have observed one mid-size PV system. There are more mid-size and a number of large-size PV systems in operation in Bangladesh. These PV systems have required a large amount of installation cost. Therefore, monitoring of the performance of these PV systems is necessary to ensure the maximum energy production from these PV plants as a lot of money is invested. For these purpose, we want to observe more such PV systems so that we can build up a general guideline to ensure the maximum energy production from the PV system.

Here, we have calculated solar insolation analytically. By using improved technology and instruments it is possible to measure real time solar insolation to get more reliable estimation of performance indices. After executing the guideline, a repeat experiment on the same system can be done to verify the improved performance. This repeat experiment will help to ensure that the provided guideline is effective for the experimented PV system as well as for the other PV systems which are facing similar troubles like the experimented one.



# REFERENCES

- [01] Renewables 2016, “Global Status Report”, Renewable Energy Policy Network for the 21<sup>st</sup> Century. [Online]. [http://www.ren21.net/wp-content/uploads/2016/06/GSR\\_2016\\_Full\\_Report.pdf](http://www.ren21.net/wp-content/uploads/2016/06/GSR_2016_Full_Report.pdf)
- [02] U.S. Department of Energy, Office of Energy Efficiency & Renewable Energy, “2016 Renewable Energy Data Book”. [Online]. <https://www.nrel.gov/docs/fy18osti/70231.pdf>
- [03] Bangladesh Power Development Board, “Development of Renewable Energy Technology.” [Online]. [http://www.bpdb.gov.bd/bpdb/index.php?option=com\\_content&view=article&id=26&Itemid=24](http://www.bpdb.gov.bd/bpdb/index.php?option=com_content&view=article&id=26&Itemid=24)
- [04] Sustainable & Renewable Energy Development Authority, Power Division, Ministry of Power, Energy and Mineral Resources, Govt. of the Peoples Republic of Bangladesh, “Present Scenario of Renewable and Sustainable Energy Sources Compare to Conventional Sources.” [Online]. [http://www.sreda.gov.bd/index.php/site/re\\_present\\_status/1](http://www.sreda.gov.bd/index.php/site/re_present_status/1)
- [05] G. M. Masters, “The solar resource,” in *Renewable and Effective Electric Power System*. Hoboken, New Jersey: Wiley & Sons, Inc., ch 7, ch 8, ch 9.
- [06] T. Bano, KVS Rao, “Performance analysis of 1MW grid connected photovoltaic power plant in Jaipur, India,” 2016 International Conference on Energy Efficient Technologies for Sustainability (ICEETS), pp. 165-170, April 2016.
- [07] S. Chowdhury, M. Al-Amin, S. Sanjari, S. Tasnim, M. Ahmad, “Performance parameter analysis of grid connected building integrated photovoltaic application in Bangladesh,” 2012 International Conference on Informatics, Electronics & Vision (ICIEV), pp. 870-875, May 2012.
- [08] R. A. Rahman, S. I. Sulaiman, A. M. Omar, S. Shaari, Z. M. Zain, “Performance analysis of a grid-connected PV system at Malaysian Energy Centre, Malaysia,” 2010



4th International Power Engineering and Optimization Conference (PEOCO), pp. 480-483, June 2010.

- [09] "Solar Electric System Design, Operation and Installation - An Overview for Builders in the U.S. Pacific Northwest," 2009 Washington State University Extension Energy Program, October 2009. [Online].  
<http://www.energy.wsu.edu/Documents/SolarPVforBuildersOct2009.pdf>
- [10] Alternative Energy Tutorials, "Grid Connected Solar PV System." [Online].  
<http://www.alternative-energy-tutorials.com/solar-power/grid-connected-pv-system.html>
- [11] S. B. Kjaer, J. K. Pedersen, F. Blaabjerg, "A review of single-phase grid-connected inverters for photovoltaic modules" IEEE Transactions on Industry Applications, Vol. 41, Issue 5, pp. 1292-1306, October 2005.
- [12] J. Carrasco, L. Franquelo, J. Bialasiewicz, E. Galván, R. Guisado, M. Prats, J. León, N. Moreno-Alfonso, "Power-Electronic Systems for the Grid Integration of Renewable Energy Sources: A Survey," IEEE Transactions on Industrial Electronics, Vol. 53, No. 4, pp. 1002-1016, August 2006.
- [13] A. Pregelj, M. Begovic, A. Rohatgi, "Impact of inverter configuration on PV system reliability and energy production," Twenty-Ninth IEEE Photovoltaic Specialists Conference, 2002.
- [14] J. Myrzik, M. Calais, "String and module integrated inverters for single-phase grid connected photovoltaic systems - a review," IEEE Bologna Power Tech Conference Proceedings, 2003, vol.2.
- [15] B. H. Chowdhury, and A. W. Sawab, "Evaluating the Value of Distributed Photovoltaic Generations in Radial Distribution Systems," IEEE Transactions on Energy Conversion, Vol. 11, No. 3, pp. 595-600, September 1996.
- [16] T. Hoff, and D.S. Shugar, "The Value of Grid-Support Photovoltaics in Reducing Distribution System Losses," IEEE Transactions on Energy Conversion, Vol. 10, No. 3, pp. 569-576, September 1995.

- [17] T. Hoff, H. J. Wenger, and B. K. Farmer, "The Value of Grid-Support Photovoltaics in Providing Distribution System Voltage Support," in Proc. American Solar Energy Society Annual Conf., San Jose, CA, 1994.
- [18] M. M. El-Gasseir, K. P. Alteneder, J. Bigger, "Enhancing Transformer Dynamic Rating through Grid Application of Photovoltaic Arrays," Proceedings of the 23rd IEEE PV Specialists Conference, May 1993.
- [19] A. S. Anees, "Grid integration of renewable energy sources: Challenges, issues and possible solutions," 2012 IEEE 5th India International Conference on Power Electronics (IICPE), pp. 1-6, December 2012.
- [20] V. Kumar, A. S. Pandey, S. K. Sinha, "Grid integration and power quality issues of wind and solar energy system: A review," 2016 International Conference on Emerging Trends in Electrical Electronics & Sustainable Energy Systems (ICETEESES), pp. 71-80, March 2016.
- [21] N. Phannil, C. Jettanasen, A. Ngaopitakkul, "Power quality analysis of grid connected solar power inverter," 2017 IEEE 3rd International Future Energy Electronics Conference and ECCE Asia (IFEEEC 2017 - ECCE Asia), pp. 1508-1513, June 2017.
- [22] C. Tao, D. Shanxu, C. Changsong, "Forecasting power output for grid-connected photovoltaic power system without using solar radiation measurement," The 2<sup>nd</sup> International Symposium on Power Electronics for Distributed Generation Systems, pp. 773-777, June 2010.
- [23] W. Jewell, R. Ramakumar, "The Effects of Moving Clouds on Electric Utilities with Dispersed Photovoltaic Generation," IEEE Transactions on Energy Conversion, Vol. EC-2, Issue. 4, pp. 570-576 December 1987.
- [24] E. Serban, M. Ordonez, C. Pondiche, "Voltage and Frequency Grid Support Strategies Beyond Standards," IEEE Transactions on Power Electronics, Vol. 32, Issue. 1, pp. 298-309, January 2017.
- [25] J. F. Jockell, S. Rahman, "Application of high resolution insolation data for photovoltaic system design analysis," Southeastcon '89. Proceedings. Energy and Information Technologies in the Southeast., IEEE, Vol. 3, pp. 1430-1435.

- [26] W. T. Jewell, R. Ramakumar, S. R. Hill, "A study of dispersed photovoltaic generation on the PSO system," IEEE Transactions on Energy Conversion, Vol. 3, Issue. 3, pp. 473-478, September 1988.
- [27] Y. T. Tan, D. S. Kirschen, "Impact on the Power System of a Large Penetration of Photovoltaic Generation," IEEE Power Engineering Society General Meeting, pp. 1 – 8, June 2007.
- [28] G. A. Vokas, A. V. Machias, "Harmonic voltages and currents on two Greek islands with photovoltaic stations: study and field measurements," IEEE Transaction on Energy Conversion, vol. 10, no. 2, pp. 302-306, Jun 1995.
- [29] A. R. Oliva, J. C. Balda, "A PV dispersed generator: a power quality analysis within the IEEE 519," IEEE Transactions on Power Delivery, vol. 18, no. 2, pp. 525-530, April 2003.
- [30] J. H. R. Enslin, P. J. M. Heskes, "Harmonic interaction between a large number of distributed power inverters and the distribution network," IEEE Transactions on Power Electronics, vol. 19, no. 6, pp. 1586-1593, November 2004.
- [31] A. Kotsopoulos, P. J. M. Heskes, M. J. Jansen, "Zero-crossing distortion in grid-connected PV inverters," IEEE Transactions on Industrial Electronics, vol. 52, no. 2, pp. 558-565, April 2005.
- [32] U. S. Department of Energy, Energy Efficiency & Renewable energy, "Solar Energy Technologies Program," October 2010. [Online]. <https://www.nrel.gov/docs/fy11osti/48969.pdf>
- [33] International Renewable Energy Agency, "The Power to Change: Solar and Wind Cost Reduction Potential to 2025," ISBN: 978-92-95111-97-4 (PDF), [Online]. [www.irena.org/DocumentDownloads/Publications/IRENA\\_Power\\_to\\_Change\\_2016.pdf](http://www.irena.org/DocumentDownloads/Publications/IRENA_Power_to_Change_2016.pdf)
- [34] Optimum Energy Services, "Financial Benefits of Grid Tied Solar." [Online]. <http://optimumenergy.co.za/solar-power/financial-benefits-of-grid-tied-solar/>
- [35] Technical specification of EverExceed ESM300 300Wp solar panel. [Online]. [https://pulsar.kiev.ua/uploads/pdf/PV\\_Module\\_catalog.pdf](https://pulsar.kiev.ua/uploads/pdf/PV_Module_catalog.pdf)

- [36] Technical specification of SUNNY TRIPOWER STP 17000TL-10 3-phase inverter. [Online]. <http://files.sma.de/dl/8552/STP15-17TL-10-BE-en-10W.pdf>
- [37] Zenith & Azimuth Angle, MIDC SPA Calculator. [Online]. <https://midcdmz.nrel.gov/solpos/spa.html>
- [38] Average Terrestrial Horizontal Irradiance, Photovoltaic Geographical Information System - Interactive Maps. [Online]. <http://re.jrc.ec.europa.eu/pvgis/apps4/pvest.php>
- [39] Trapezoidal numerical integration. [Online]. <https://www.mathworks.com/help/matlab/ref/trapz.html>
- [40] J. Singh, B. K. Bhattacharya, M. Kumar, K. Mallick, “Modelling monthly diffuse solar radiation fraction and its validity over the Indian sub-tropics,” International Journal of Climatology, Int. J. Climatol. 33, pp. 77–86, Available in Wiley Online Library, November 2011. [Online]. <http://onlinelibrary.wiley.com/store/10.1002/joc.3408/asset/3408 ftp.pdf>
- [41] B. Marion, J. Adelstein, K. Boyle, H. Hayden, B. Hammond, T. Fletcher, B. Canada, D. Narang, D. Shugar, H. Wenger, A. Kimber, L. Mitchell, G. Rich, T. Townsend, “Performance parameters for grid-connected PV systems,” Conference Record of the 31<sup>st</sup> IEEE Photovoltaic Specialists Conference, pp. 1601–1606, February 2005.
- [42] L. M. Ayompe, A. Duffy, S. J. McCormack, M. Conlon, “Measured performance of a 1.72kW rooftop grid connected photovoltaic system in Ireland,” Energy Conversion and Management, pp. 816-825, August 2010.